

Principles of Operation

The internal construction of the typical AI - Tek variable reluctance sensor is a magnet, pole piece and coil (See figure 1). A magnetic field (lines of flux) extends from the magnet, through the pole piece and coil out into the air space at the end of the sensor. The return path of the magnetic field is from the air space to the other end of the magnet. As a ferrous object approaches the tip of the pole piece, the magnetic field increases and then decreases as the object moves away from the pole piece. The snap or the rapid change in the magnetic field induces an AC voltage signal in the coil. With an ideal target and matching sensor, the induced voltage is in the shape of a sine wave.

As can be seen, the generated frequency signal is directly proportional to the number of ferrous objects passing the pole piece per unit time. The amplitude of the voltage output is proportional to the speed of the ferrous objects passing the pole piece.

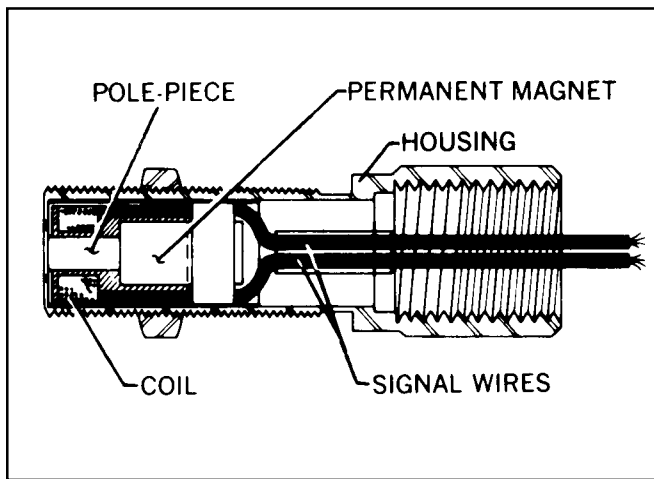

Figure 1 - Internal configuration of typical sensors.

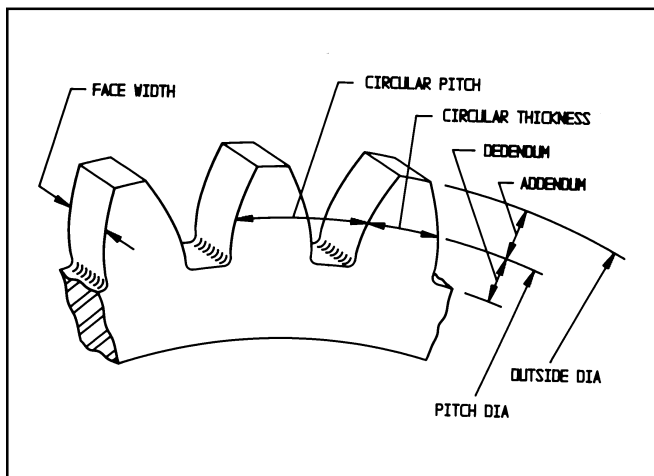

Figure 2 - Common terms used in defining gears.

Many applications of AI - Tek magnetic sensors use gears as targets. Typical sensor output wave forms with various targets are illustrated in Figure 3. Testing sensors with gears rather than other ferrous discontinuities such as sprockets, keyways, boltheads, etc. is because the output is predictable and repeatable. See Figure 2 for commonly used gear terminology.

$$\text{Diametral Pitch} = \frac{\text{No. of Teeth} + 2}{\text{Outside Dia. of Gear (in.)}}$$

The performance of a sensor can be easily defined when using a gear for a target; it also allows for estimated performance with alternate targets. Airpax sensors are tested with AGMA standard gears; the performance curves are included in this catalog.

Airpax Instruments differs from most sensor manufactureres in the presentation of performance curves and test parameters. Most existing data is specified at a surface speed of 1000 in/sec and 0.005 in. air gap; we feel that a 0.030 in. air gap and 500 in/sec. surface speed (1800 RPM motor with 5 to 6 in. dia. gear) are more realistic parameters to specify performance.

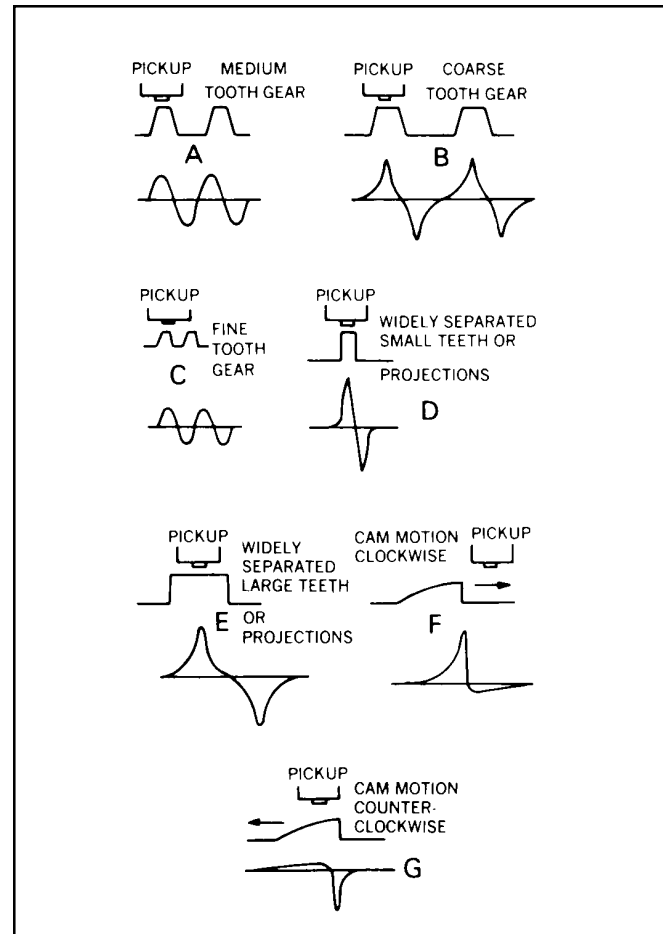

Figure 3 - Generated voltage waveforms.