

CHEM TEC EQUIPMENT COMPANY

INSTALLATION AND MAINTENANCE MODEL LCA SERIES

OPERATION:

As flow is increased, the magnetic piston is forced against the bias spring until the magnetic field comes into contact with the reed switch causing the switch to actuate, indicating proper flow. As flow decreases, the spring forces the piston in the opposite direction, deactuating the reed switch, indicating a reduced or no flow situation.

SPECIFICATIONS:

MODEL	FLOW SETTINGS	
	ADJUSTABLE RANGES INCREASING FLOWS WATER GPM (LPM)	FACTORY PRESET DECREASING FLOWS WATER GPM *
LCA-250	0.1 - 4.0 (0.38-15.1)	-10 0.1 -20 2.5 -30 3.0
LCA-375	0.5 - 4.0 (1.89-15.1)	-10 0.5 -20 2.5 -30 3.0
LCA-500	0.5 - 10.0 (1.89-37.9)	-10 0.5 -20 5.0 -30 7.5
LCA-750	1.0 - 15.0 (3.75-56.2)	-10 1.0 -20 5.0 -30 7.5

* -00 All models no factory setting
Differential between ON and OFF averages 40%
Repeatability ±2%

BODY MATERIAL	MAXIMUM WORKING PRESSURE	WETTED PARTS
PVC	100 psig	PVC, epoxy, 316SS
Acrylic	100 psig	Acrylic, epoxy, 316SS
Brass	1500 psig	Brass, epoxy, 316SS
316S.S.	3000 psig	316S.S., epoxy, 316SS

SWITCH DATA

	SPST	SPDT
Maximum Switching Voltage		
DC	200	100
AC	150	-
Contact Rating		
DC(W)	50	3
AC(VA)	70	-
Maximum Switching Current (A)		
DC	1.0	.25
AC	0.7	-

SPDT switch is not UL recognized

Above values for resistive loads only. For inductive loads, surge current and rush current - contact protection is required, consult your local representative.

SPST leads 24 in. min. from body, Red and Black

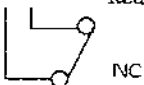

22 AWG PVC Jacketed wire

SPDT (Optional) leads 24 in. min. from body.

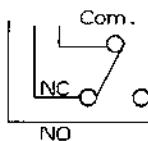

- Green - NO
- Red - NC
- Black - Common

22 AWG PVC Jacketed wire

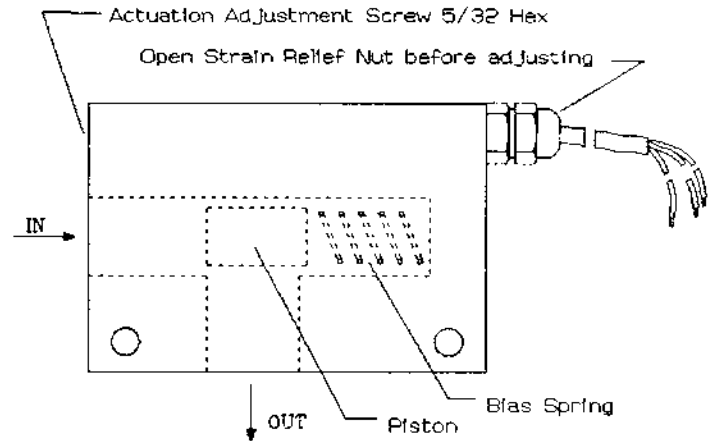

PORTS:	LCA-250	LCA-375	LCA-500	LCA-750
	1/4" FNPT	3/8" FNPT	1/2" FNPT	3/4" FNPT

INSTALLATION:

The flow switch should be installed with the inlet horizontal, outlet vertically down. Avoid dirt, Teflon tape shred, or other foreign material from entering unit. Do not use pipe dope. We recommend use of a 100 micron filter.

The standard unit is provided with a SPST, NC (Close at rest) dry reed switch. Increasing flow above the actuation point will open the switch, decreasing flow below the actuation point will close the switch. SPDT models have both NO and NC capabilities.

Large metallic bodies and magnetic fields may affect the principle of operation of these units. If disturbance is suspected, adjustment of the reed switch may be necessary. Magnetic shielding may be required in severe cases.

TO SET SWITCH ACTUATION POINT:

- A. For increasing flow actuation point:
 1. Establish flow at desired actuation point.
 2. Open strain relief nut.
 3. Turn adjustment CW until switch deactuates.
 4. Turn adjustment CCW until switch actuates.
- B. For decreasing flow actuation point:
 1. Establish flow at desired actuation point
 2. Open strain relief nut.
 3. Turn adjustment CW until switch actuates.
 4. Turn adjustment CCW until switch deactuates.

MAINTENANCE:

REED SWITCH REPLACEMENT:

1. Shut flow off.
2. Remove strain relief from body.
3. Remove and replace reed switch capsule.
4. Establish flow rate at which actuation should occur.
5. Follow the above procedure to set actuation point.

PARTS LIST:

SPST Unit P/N: A1041 SPST 1 AMP
SPDT Unit P/N: A1041 SPDT .3 AMP

LCAI&M\050997