

Switching Power Supplies Connected to the Intermediate DC-bus New Possibilities, New Features

Bernhard Erdl, President PULS GmbH

Power supplies with a DC input voltage of 360-900V can be directly connected to the intermediate DC-bus of a frequency drive. The advantages are interesting but special precautions are required when connecting the power supply.

Power supplies for control systems and other applications are traditionally connected to either a 1-phase or 3-phase AC mains. However, due to the increasing use of frequency drives and amplifiers, there is a new option of connecting the power supplies to the intermediate DC-bus of the frequency drive (Figure 1). One of the greatest advantages is that you can use the kinetic energy of the motors as a way of supplying the control system and this energy storage is practically free because it already exists. This intriguing configuration significantly increases the stability against AC mains fluctuations without needing to employ a battery back up and its associated costly maintenance.

A good example is use in a crane application. What happens when a crane has just hoisted its load up into the air and the AC power fails? Normally, the control system would have to be battery backed up so that power is available when lowering the load back to the ground. However, if



the control system is supplied through the intermediate DC-bus, the crane's motor can act as a generator when the load is lowered. The energy from the motor keeps the intermediate DC-bus voltage live which in turn keeps the power supply

energized allowing for DC power for the control system simplifying and increasing the reliability of the design.

There are many applications where the PULS QTD20.241 can benefit from

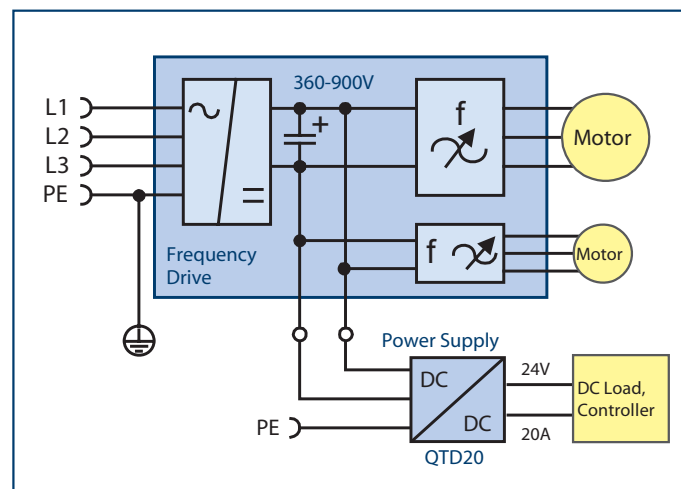

Figure 1:
Power supply is connected to the DC-bus and not to the AC mains

costly breakage of tools and material due to AC mains failures and fluctuations. Some examples are textile, paper, grinding machines as well as crane applications previously mentioned. The QTD20.241 can keep the control system energized long enough to provide a controlled and safe shut down of equipment during power loss making it the perfect choice as an addition to your drive system.

What special requirements does a power supply that is suitable for the intermediate DC-bus need?

One could think there are no special requirements needed because at least from the basic design principle, switching power supplies can be operated with both AC and DC. Sometimes power supplies are also specified with a DC voltage range of 450-750V, so why do problems arise in practical use when they are connected to the intermediate DC-bus?

One of the reasons is that the voltage of an intermediate DC-bus is often a high-frequency AC voltage with several hundred Volts of amplitude and switching voltage edges against ground (Figure 2). True „DC voltage“ applies only to the voltage between the positive and negative terminals but is not referenced to ground.

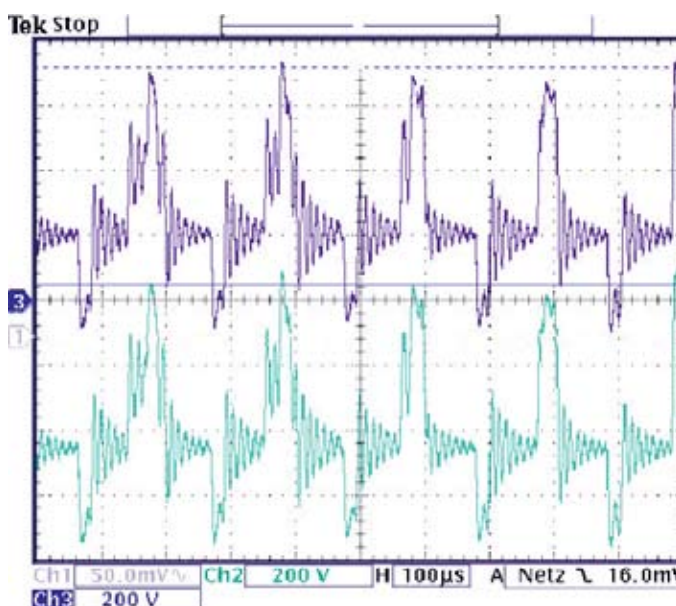

Figure 2:
800Vdc between the plus and minus pole
Upper curve: plus pole to ground
Lower curve: minus pole to ground

However, the intermediate DC-bus jumps back and forth in common mode referenced to ground. This effect occurs because the switching circuits (IGBTs) in the frequency drive alternately connect the positive and negative terminal of the intermediate DC-bus voltage with ground through the motor and other capacitances in the circuit (Figure 3).

The frequency drives do have EMI filters, but these only work on the power lines and do not block noise, on the intermediate DC-bus. The rea-

son is that the circuit is internal and there are no EMC regulations that cover this section of the drive. The EMC regulations for power lines also do not cover this section, because the AC mains voltage is somewhat „cleansed“ through compliance with the standards. No supply voltage is defined on which there is continuous interference of 600V amplitude in the kHz range with switching edges.

The interference on an intermediate DC-bus exceeds the permissible values for a power line by many factors of ten and therefore the requirements for a power supply connected to an intermediate DC-bus are quite different than for a typical power supply.

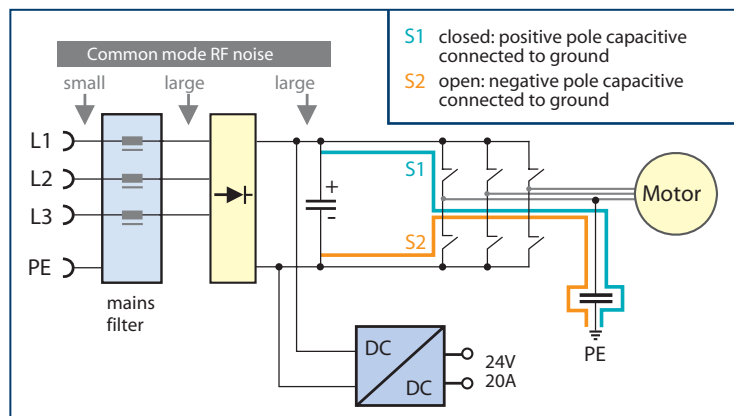

Figure 3: Origin of the high common mode RF noise

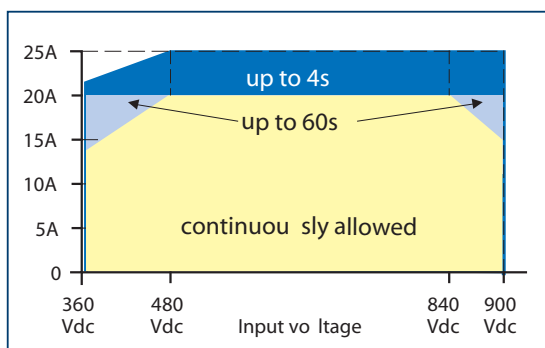

Figure 4: Allowed output current vs. input voltage

PULS QTD20.241 offers an application-specific power supply with a continuous output of 24V and 20A. One important difference from standard PULS power supplies is that the direction of the EMI filter has been turned around. Normally, the filters are arranged so that the interference generated in the power supply do not feed back to the power lines which must be kept clean. However, in an intermediate DC-bus connection the filters should block the interference generated from this connection. The interference produced from the power supply does not need to be filtered because it goes back to the unclean intermediate DC-bus and the existing filter in the drive can eliminate this interference. In compliance with the applicable standards, special DC fuses are integrated in the input stage of the QTD20.241 and the devices are UL508 listed. If the power

supply is accidentally connected with reverse polarity the unit will simply not start.

Another added feature is the wide DC input range of 360V to 900V (Figure 4), which is wider than a typical AC power supply. The lower value is important

for the unit to work with poor AC mains and in the event of a power failure. PULS also built in a large reserve for when the motors are braking and return their energy. During this period the voltage can rise very high before the voltage limiter in the drive intervenes. Should the voltage exceed 900V, there is additional protection in the power supply which switches itself off. In addition to the buffering from the intermediate DC-bus, the power supply can also offer an additional ride through time of 0.022 seconds at 20A with its built-in electrolytic capacitors.

The ground-breaking design of the QT20 series served as a platform for the development of the QTD20 („D“ for DC input). There are many similar features between the two supplies consisting of a compact design that is only 65mm wide, efficiency up to 95%, an output DC-OK-signal and fast connect spring clamp terminals just to mention a few. Due to the wide input range, the bonus power had to be reduced to 25% for up to four seconds but it still offers a large reserve for dynamic loads. Modern and reliable control systems can now be easily implemented with this compact device that is specifically designed for drive applications. Should a small additional power supply be desired for the initial start-up of the AC voltage, the cost effective ML100.200 with 24V and 4A is an excellent option.