

AP377

3 Outputs

19" Power Supply, 120 Watt



- High efficiency: 86%
- ACin autoselect: 115/230V AC
- 8 HP plug in width
- Al/Mg alloy cassette fully enclosed
- H15 standard pinout
- Over-Temperature Protection (OTP)
- Meets EMC standards: VDE 0160/2, EN 61000-4, NAMUR, EN 150081-1 (EN 55022/B), EN 50082-2



Power Supply AP377

This triple-output power supply is highly efficient over the total input and output range. With low heat creation, it is small (8HP wide), light (770g) and convection cooled.

The two forward converters automatically select between 115 and 230V AC ranges, avoiding faulty configuration. The converters have a fixed phase relationship, so Vout1 is independent of Vout2/3. The DP377 can thus provide a 5V DC output completely independent of, and isolated from, a 24V (2x12V) or 30V (2x15V) DC output.

EMC compatibility is a major feature. It has low spurious noise, and noise suppression meets VDE 0871 class B. Noise immunity meets IEC 1000-4-4 (IEC 801-4) level 4 and VDE 0160 VDE 0160 class 2, even at full load. Over-voltage and over-temperature protection avoid problems even in extreme working environments. It is highly immune to overvoltage and transients, withstanding 300V AC input for 0.5s. IEC 1000-4 (IEC 801) and VDE 0160 class 2 are satisfied even at full load.

Schematic:

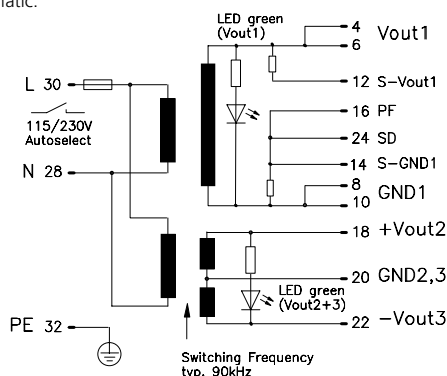

- Mechanical:** 8HP / 3U board (DIN 41494) with totally enclosed Al/Mg alloy cassette, LxWxH = 171.93 x 40.64 x 112mm, the length includes the connector, see page 4.
- Weight:** App. 770g
- Connector:** H15 (DIN 41612), coding option, max. load per pin 11A @ 70° C.

Vout [DC]	Iout	Pout	Features	Order-No.
Vout1 5V	14A	70W	ACin autoselect, PF, SD, OTP, OVP	AP377.111
2 +12V	5A	70W max.		
3 -12V	5A	70W max.		
Max. total power:		120W		
Vout1 5V	14A	70W	ACin autoselect, PF, SD, OTP, OVP	AP377.121
2 +15V	4A	70W max.		
3 -15V	4A	70W max.		
Max. total power:		120W		

"F" appended to Order No. means front panel 8 HP included and fitted.

Accessories: H15 connector, 6.3mm flat contacts: **ZP100**
H15 connector with soldering pins: **ZP120**

Warranty: 2 years from date of delivery.

Output

Voltage Vout1 adjustable	min. ± 5%	Trimmer1 on front panel.
Σ Vout2/3 adjustable	min. ± 2%	Trimmer2 on front panel.
Accuracy Vout1	max. ± 0.5%	Includes production-adjustment, line regulation, and load reg.
Vout2/3	max. ± 3%	
Sense lines Vout1	max. 0.25V	Voltage compensation per line.
Vout2/3	None	Not available.
Minimum load Vout1	None	Not necessary.
Vout2 (12V/15V)	max. 0.4A / 0.3A	Function of current of Vout3.
Vout3 (12V/15V)	max. 0.4A / 0.3A	Function of current of Vout2.
Output power Pout	max. 120W	Total power.
Noise, Ripple Vout1, 2/3 including spikes	max. 30mVpp, 50mVpp	20Hz...200kHz.
Over-voltage protection	typ. 6.3V	20Hz...20MHz.
Derating	3W/K	Vout1, threshold accur. ± 3.5%.
Operating indicator	2 green LED's	+55° to +70°C Ta.
Isolation Vout to Vin	SELV	On the front, Vout1, Vout2+3.
Vout1 to Vout2/3	200V AC	EN 60 950, VDE 0805.
All outputs are protected against open-circuit, short-circuit, and overload.		

Input

Line input AC 1	110...120V AC	115/230V autoselect.
• Range	98...132V AC	Full spec.
Line input AC 2	80...132V AC	Derated, see page 2.
• Range	220...240V AC	115/230V autoselect.
	196...264V AC	Full spec.
Line frequency	160...300V AC	Derated, see page 2.
Input current rms	47...63Hz	400Hz, see page 2.
Noise suppression	max. 3.5Aeff. / 1.4Aeff.	@ 115/230V AC.
	EN 55 022/B	10kHz...30MHz, conducted.

Specifications are valid at 230V AC, unless otherwise stated. They are subject to change without prior notice.

AP377 · 3 Outputs · 19" Power Supply · 120 Watt

Output (continued)				AP377.111		AP377.121		
				5V	±12V	5V	±15V	
Voltage regulation								98...132V AC / 196...264V AC, I _{out} = 100%. I _{out} = 50%, Δ I _{out} = ±50%, sense lines connected. 10%...90%...10% load change, 90% rise time dt = typ. 20μs. Till ΔV _{out} is within < 0.5% of final value.
· Line regulation		max.	%	± 0.1	± 0.3	± 0.1	± 0.3	
· Load regulation stat.	Δ U _{stat}	max.	%	± 0.1	± 3	± 0.1	± 3	
· Load regulation dyn.	Δ U _{dyn}	max.	%	± 10	± 3	± 10	± 3	
Response time	t _s	max.	μs	500	500	500	500	
· Temperature coefficient		typ.	%/K	± 0.01		± 0.01		
Ripple		max.	mVpp	30	50	30	50	
· incl. spikes		max.	mVpp	50	80	50	80	
Current limitation								Fixed. Fixed, total power. Approximately constant current.
· Threshold V _{out1}		min/max.	A	105% ... 120% of I _{out1}				
· Threshold V _{out2/3}		min/max.	W	73.5 ... 84				
· Characteristics								
· Short-circuit V _{out1}		max.	A	1.4 x I _{out}				
Short-circuit V _{out2/3}		max.	A	1.8 x I _{out}				
Minimum load								See graph on page 3.
· V _{out2}			A	—	0...0.4	—	0...0.3	Dependent on current at V _{out3} .
· V _{out3}			A	—	0...0.4	—	0...0.3	Dependent on current at V _{out2} .
Start delay	t _{Delay}	typ.	ms	400		400		After switch on.
V _{out} rise up time	t _{Rise}	typ.	ms	10		10		95% t _o t _{Delay} t _{Rise} V _{out}
On and off characteristic								Approximately monotonic.

Input (continued)

AC input range 1 / 2		V AC	98...132 / 196...264				Full spec.
DC-input range		V DC					Not admissible
Derated AC range 1 / 2		V AC	80...98 / 160...196, 300 for 0.5s				
Frequency range		Hz	47...63				Full spec.
Derated frequency range		Hz	63...440				Increased leakage currents.
In-rush current	max.	A	25				No wait time for switch on / off. NAMUR standard met.
Hold-up time	min.	ms	22				@ 98V AC, I _{out} = 100%.
	min.	ms	24				@ 196V AC, I _{out} = 100%, see graph on page 3.
Power factor λ	typ.		0.57				@ 98V AC, I _{out} = 100%.
Internal fuse			5x20mm T5A/250V (IEC 127/2-5)				To replace, see page 4.
Input range selection			ACin autoselect				

Logic Functions

PF/PG-signal			Power fail + V _{out1} watch				Open-collector (I _{max} = 5mA).
· PF/PG low			5ms before V _{out1} < 4,75V				
· PF/PG high if			ACin > 89/173V AC and V _{out1} > 4,5V				
Hold-up time							See graph on page 3, I _{out} = 100%.
· from power failure to PF-signal	min.	ms	16				@ 196V ACin.
· from PF-signal	min.	ms	5				
SD remote switch off			Low-switch off				See drawing on page 4.
V _{out} adjustable	min.	%	± 5	± 2 (Σ)	± 5	± 2 (Σ)	Position for trimmer see on page 4.

Electromagnetic Compatibility

Emissions according to EN 80081-1			Class B				EN 50081-2 is also satisfied
· Radio interference, EN 55011, EN 55022							Conducted 10kHz...30MHz.
Immunity according to 50082-2							EN 50082-1 is also satisfied
· Electrostatic discharge ESD, EN 61000-4-2			8kV direct discharge (level 4) 15kV air discharge (level 4)				
· Radiated fields, EN 61000-4-3			10V/m (level 3)				To ACin, V _{out} and signal lines: length = 1m.
· Fast transients, EN 61000-4-4			4kV (level 4) 2kV (level 3) 2kV (level 4) cap. coupling				Coupled to ACin line. Coupled to DCout line.
· Surge transients, EN 61000-4-5			4kV (isolation class 4) 2kV (isolation class 4)				Coupled to V _{out} and signal lines. Common mode, unit on.
· Transient voltage, IEC 255			5kV				Differential mode, unit on. Common mode, unit off.
· NAMUR-prescription			Satisfied				
· Transient resistance, VDE 0160 §5.3.1.1.2			750V / 1.3ms (class 2)				Valid for total load range.
· Over-voltage resistance (PULS standard)			300V AC / 0.5s				

Min. Hold-Up Time

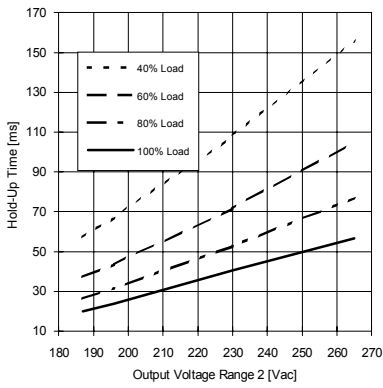

Typ. Voltage Deviation Full Load

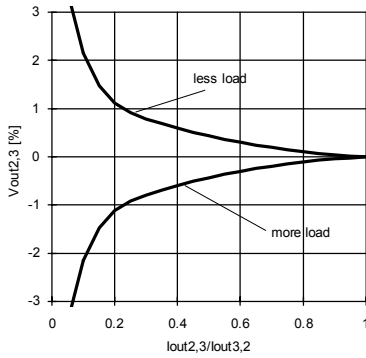

Typ. Derating over Temperature

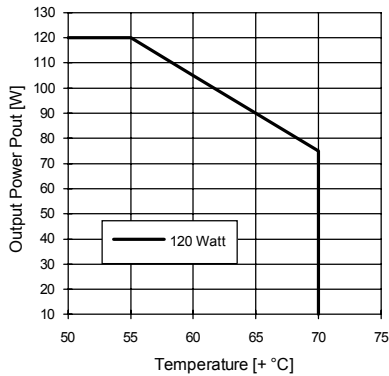

Typ. Efficiency

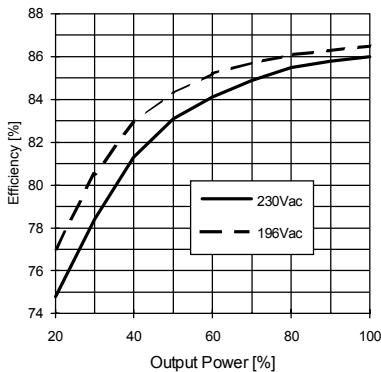

Protection

Unit protection

· Overload	Yes	See current limit.
· Short-circuit proof	Yes	Auto voltage return.
· Open-circuit proof	Yes	
· Over-temp. (OTP) on heatsink	typ. +120° C	Switch off.
· Reverse battery prot.	typ. +110° C	Switch on (automatically).
· ACin range selection	Yes	
	Auto select	

Load protection

· Over-voltage (OVP) Threshold	Yes	Switch off.
Accuracy	typ. 6.3V	Valid for Vout 1.
Method	max. ± 3.5%	
	15V Z-Diodes	Vout 2/3, AP377.111.
	18V Z-Diodes	Vout 2/3, AP377.121.

Safety

Electrical safety

· Test voltage (each unit) according to EN 60 950 for t = 2sec	3kV AC	Primary / secondary.
	2.5kV AC	Primary / PE.
	500V AC	Secondary / PE.
· Air- and leakage distance	6.4 / 8mm	Primary / secondary.
	4mm	Primary / PE.
· Isolation resistance	min. 5MΩ	VDE 0551.
· Protection class	I	VDE 0106 part 1, IEC 536.
· PE resistance	< 0.1Ω	VDE 0805.
· Protection system	IP20	DIN 40050, IEC 529.
· Leakage current	max. 0.75mA	EN 60 950 (47...63Hz line) .
· Safe low voltage	SELV	EN 60 950, VDE 0805, VDE 0160.
· Over voltage class	II	VDE 0110 part 1, IEC 664.

Touch safety

	Finger test	VDE 0100 §6, EN 60 950, VBG4.
· Penetration protection	> Ø 3mm	e.g. screws, small parts etc.

Operation and Ambient Area

Application class	KSF	DIN 40040.
Operation temperature	max. 0° ... +70°C	Ta (measured at 1cm distance).
· Derating range	+55° ... +70°C	Derating, see diagram.
Storage temperature	typ. -20° ... +100°C	Ta.
Humidity	max. 95%	Non-condensing.
Mechanical usage	Vertical	See page 4.
· Lateral spacing	1 HP	To reach the specified values.
Cooling	Normal convection	Don't obstruct air flow.
Dirt protection level	max. 2	VDE 0110 part 1.
Vibration	0.075mm	IEC 68-2-6 (10...60Hz).
Shock	11ms / 15g	IEC 68-2-27 (3 shocks).
Operation Height	max. 2,000m	Above sea level.

Efficiency and Power Loss

AP377.111 and .121	typ. 86% / 20W	@ 230V ACin, Iout = 100%.
--------------------	----------------	---------------------------

Reliability and Lifetime

MTBF according to Siemens

standard SN29500	typ. 200,000h	230VAC, Iout = 100%, +40°C Ta.
Only long life (2,000h @ 105° C) electrolytic capacitors are used.		
Function test	100%	Test certificate enclosed.
In-circuit test	Yes	
Run-in (burn-in)	24h	Full load, Ta = +55° C, on/off cycle.

Fuse

The PSU has electronic protection against external short-circuits. In case of an internal defect, a fuse disconnects the unit. It can only be replaced by opening the unit which should be done by the supplier.

Installation for Operating

The unit is constructed for 19" systems:
 Ensure that pin 4 of H15 connector is on top. For other installation considerations consult your representative. Ensure free air flow.

Dimensions and Connections

19" board, with totally enclosed Al/Mg alloy cassette.
 8HP plug in width. See figure below for dimensions.

- 1) Do not remove any screws on box, as internal safety connections could be disconnected!
- 2) Vout1 adjustable at trimmer1 (min. ± 5%),
 Σ Vout2/3 adjustable at trimmer 2 (min. ± 2%).

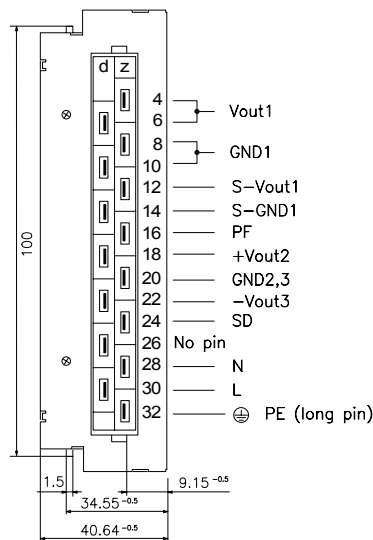

H15 pinout (DIN 41312)
 NC = No Connection - Do not use!

Schematic

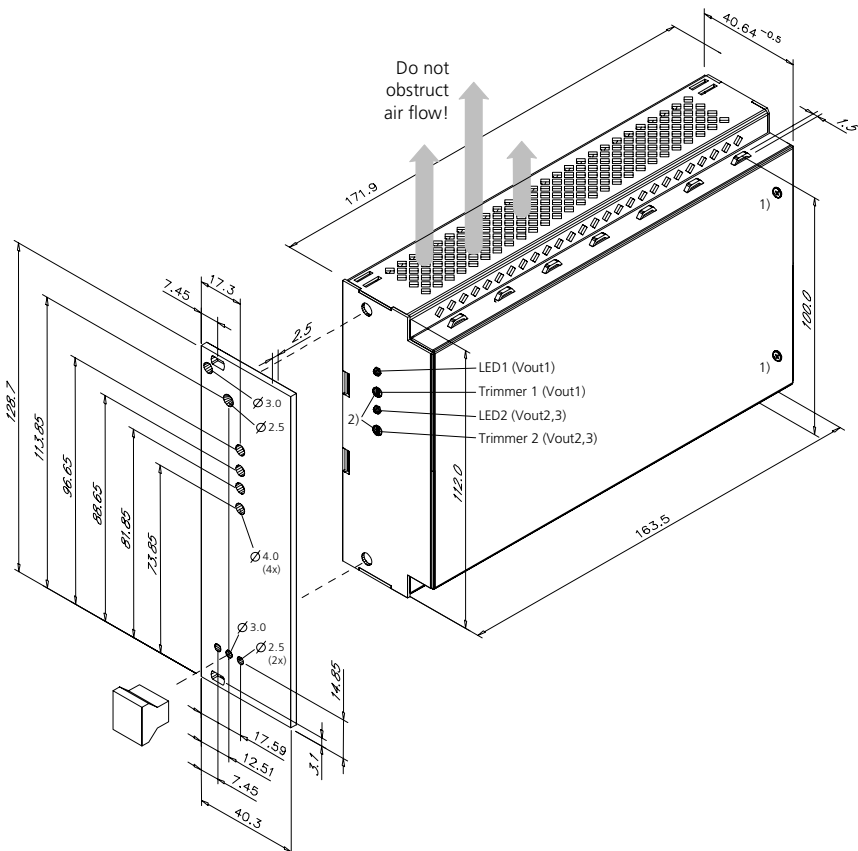
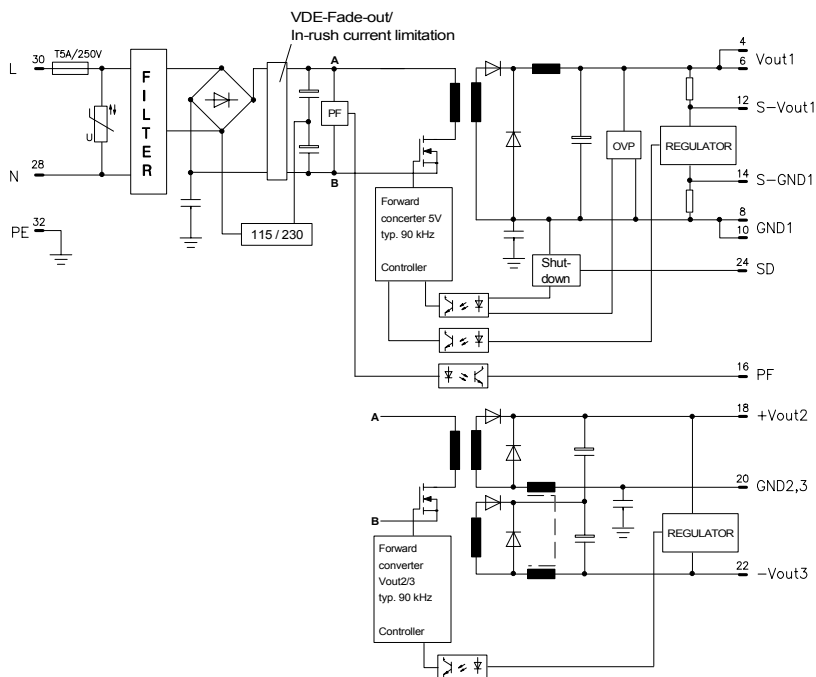

Modifications (contact supplier)

Without ACin autoselect (230V range only).
 Other output ranges.
 Lower cost versions.