

AP486.503

3 Outputs

DIN Rail Power Supply, 112 W

- ◆ ACin 92...132 VAC
- ◆ Hold-up time: 250 ms
- ◆ Optional mounting position
- ◆ Over Temperature Protection (OTP)
- ◆ 81% Efficiency
- ◆ Meets EMC standards: EN 50081-2 (EN 55022/A), EN 50082-2, VDE 0160/2, NAMUR



Data sheet

This 3-output power supply is characterised by a very high hold-up time. The design of the unit guarantees a high efficiency ratio over the whole load and input voltage range.

Over-voltage and over-temperature protection (OVP, OTP) as well as current limitation on the 5V output make sure that problems arising from operation of the unit under unusual environmental conditions are avoided.

The power supply unit is designed for DIN rail mounting on the side panel of a control cabinet. The mounting position can be freely chosen by the user by simply unscrewing the power supply unit from its mounting bracket, rotating it (vertical axis of rotation: 180°) and re-mounting it onto the bracket. Care must be taken, however, not to install the unit with the label upside down.

Schematic (symbolic)

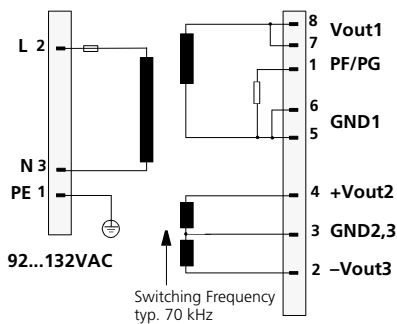

- Mechanical: ALMg alloy cover for component side, plastic cover for bottom side, Alloy bracket with DIN rail mounted either on the left side or the right side (optional) LxWxH =173 mm x 69.7 mm x 125 mm
- Weight: 940 g
- Connector: Spring clamp terminals 0.08 - 2.5mm² (included in scope of delivery) Contact load capacity max. 12A at +70°C

ⓘ	Vout	Iout	Pout	Features	Order-No.
Vout1	+5.2 V	10 A	52 W	PF, OVP, OTP	AP486.503
Vout2	+15 V	2 A	30 W		
Vout3	-15 V	2 A	30 W		
Max. total power: 112 W					

Warranty: 2 years from date of delivery.

Output

Voltage Vout1,2,3				Fixed
◦ Accuracy	Vout1 max.		+0.4%, -1%	Includes: production-alignment, line regulation, load regulation
	Vout2/3 max.		±2%	
Sense lines			—	Not available
Minimum load				Not necessary
Output power		max.	112W	Total power
Ripple/Noise Vout1/2/3		max.		
◦ einsch. Spikes			30 mVpp	20Hz...20MHz
Over-voltage protection (OVP)typ.			6.2V	Threshold accuracy ±8%
Derating			2 W/K	+55°C to +70°C T _{amb}
Operating indicator			3 green LEDs	On the front, Vout1,2,3
Isolation Vout to Vin			SELV	EN 60 950, VDE 0805
All outputs are protected against open-circuit, short-circuit, and overload.				

Input

Line input AC		100 - 120 V AC	Wide-range converter
◦ Range		92...132 V AC	Full spec.
Line frequency		47...63Hz	DC resp. 400Hz, see pg. 2
Input current ms.	max.	3 A	
Noise suppression		EN 55 022/A	10kHz...30MHz

Output (continued)

				5.20 V	±15 V	
Voltage regulation:						
◦ Line regulation		max.	%	0.1	0.1	92 V AC...132 V AC I _{out} = 100%
◦ Load regulation stat.	ΔU _{stat}	max.	%	±1	±0.5	I _{out} =50%, Δ I _{out} = ±50%, at 115 VAC
◦ Load regulation dyn.	ΔU _{dyn}	max.	%	±7	±0.7	10%...90%...10% load change, Rise/fall time dt.= typ. 20 μs
Response time		max.	ms	1	0.3	Till Δ V _{out} is within <0.5% of final value
◦ Temperature coefficient		typ.	%/K	0.015		
Ripple						
◦ incl. spikes		max.	mV _{pp}	30	30	20Hz...20MHz, 115V AC, I _{out} = 100%
Current limitation						
◦ Threshold V _{out1}		typ.	A	17		Fixed
◦ Threshold V _{out1/2/3/4}		typ.	W	130		Fixed, total power, exceeding leads to switch off with periodic re-start
◦ Current at overload		max.	A	20	9.5	
Start delay	t _{Delay}	typ.	ms	750		t _o = switch on without C-Load
V _{out} rise-up time	t _{Rise}	typ.	ms	5		Approx. monotonic
On and off characteristic						

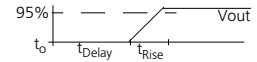
**Input** (continued)

AC input range		V AC		90...132		Full spec.
Frequency range		Hz		47...63		Full spec.
Derated frequency range		Hz		63...400		Increased leakage current
In-rush current		max.	A	70		Wait 30s before switching on again
Hold-up time (only V _{out1})		min.	ms	250		At 103.5V AC, I _{out1} 8A, I _{out2/3} 2A (see fig. on pg. 3)
Power factor	λ	typ.		0.65		At 115V AC, I _{out} = 100%
Internal fuse				5x20 mm, T6.3A/250 V (IEC127/2-5)		To replace, see note on page 4
Input range selection				–		

Logic Functions

Power Fail Signal PF				Power fail + V _{out1} watch	Open-collector signal (I _{max} = 5 mA), see pg. 3
◦ PF low				5ms before V _{out1} < 4.75V	Internal Pull-Up resistor 2.5KΩ against V _{out1}
◦ PF high				ACin > 90V AC and V _{out1} > 4.7V	V _{out2/3} are controlled by PF
Hold-up time				90V AC	see diagram on pg. 3, I _{out} = 100%
◦ from power failure to PF-signal	min.	ms		10	at 103.5V AC
◦ from PF-signal to V _{out1} < 4.75V	min.	ms		240	I _{out1} 8A, I _{out2/3} 2A

Electromagnetic Compatibility (EMC)

Emissions (EN 50081-2)				Class A	conducted 10kHz...30MHz	
◦ Radio interference (EN 55011, EN 55022)					EN50082-1 is also complied with	
Immunity (EN 50082-2)						
◦ Electrostatic discharge ESD, EN 61000-4-2				8kV direct discharge (Level 4) 15kV air discharge (Level 4)		
◦ Radiated fields, EN 61000-4-3				10V / m (Level 3)	ACin, V _{out} and signal lines: length = 1m	
◦ Burst, EN 61000-4-4				4kV (Level 4) 2kV (Level 3) 2kV (Level 4) cap coupling	Coupled to ACin line Coupled to DCout line Coupled to V _{out} and signal lines	
◦ Surge transients, EN 61000-4-5				4kV (isolation class 4) 2kV (isolation class 4)	Common mode: L to PE, N to PE, unit on Differential mode: L to N, unit on	
◦ Transient voltage, IEC 255				5kV	Common mode: L, N to PE, unit off	
◦ NAMUR prescriptions				Satisfied		

PF-Signal and Hold-up time

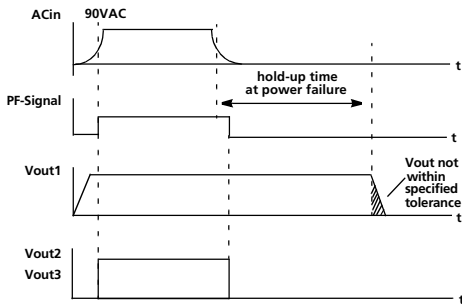

Min. Hold-Up Time

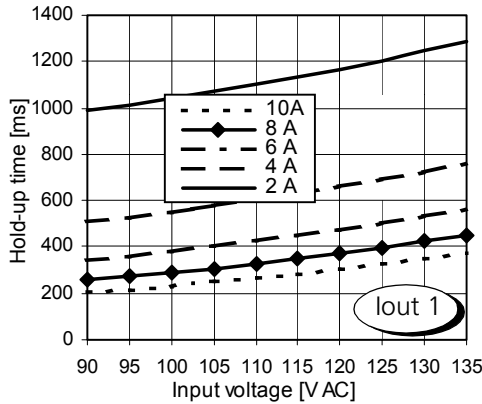

Typ. Derating over Temperature

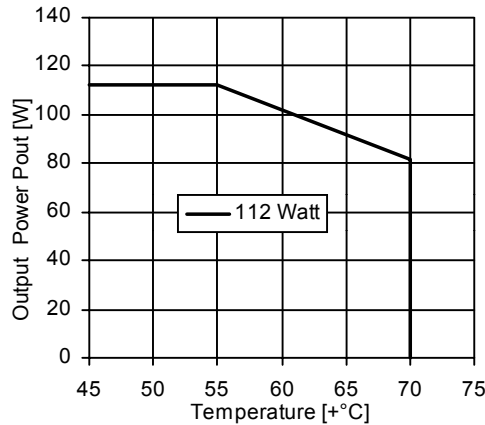

Efficiency (typ.)

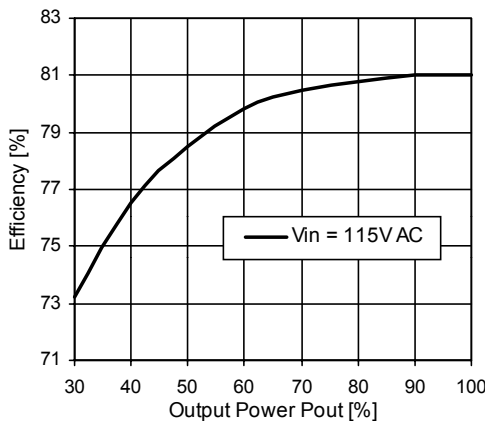

Protection and Monitoring

Unit protection

• Overload	Yes	Total power limit
Additional current limitation	Iout1: max 20A	Automatic restart
• Short-circuit proof	Yes	Automatic restart
• Open-circuit proof	Yes	
• Over-temp. protect. (OTP)	typ. +110°C typ. +105°C	Transformer temp., switch-off Transformer temp., switch-on (automatical)

Load protection

• Overvoltage protection (OVP)	Yes	
– Threshold	typ. 6.2V	for Vout1, automatic restart
– Accuracy	max. ±8%	
– Method	-	By thyristor

Safety

Electrical safety

• Test voltage (each unit) acc. EN 60 950	3kV AC 2.5kV AC 500V AC	Primary / secondary Primary / PE Secondary / PE
• Air and leakage distance	6.4 / 8mm 3.2 / 4mm	Primary / secondary Primary / PE
• Isolation resistance	min. 5MΩ	VDE 0551
• Protection class	I	VDE 0106 part 1, IEC 536
• PE resistance	<0.1Ω	VDE 0805
• Protection system	IP20	DIN 40 050, IEC 529
• Leakage current	max. 0.45mA	EN 60 950 (47-63 Hz line)
• Safe low voltage	SELV	EN 60 950, VDE 0805, VDE 0160
• Over-voltage class	II	VDE 0110 part 1, IEC 664
Touch safety	Finger test	VDE 0100 §6, EN 60 950, VBG4
Penetration protection	> Ø 3mm	e.g. screws, small parts, etc.

Operation and Ambient Area

Application class	KSF	DIN 40 040
Operation temperature	max. 0° ... +70°C	T _{amb} (measured at 1cm distance)
• Derating range	+55° ... +70°C	Derating, see left diagram
Lagertemperatur	typ. -20° ... +100°C	T _{amb}
Humidity	max. 95%	Non-condensing
Mechanical usage	Vertical	see page 4
Cooling	Normal convection	Do not obstruct air flow!
Dirt protection level	max. 2	VDE 0100 part 1
Vibration	0.075mm	IEC 68-2-6 (10-60Hz)
Shock	11 ms / 15g	IEC 68-2-27 (3 shocks)
Operation height	max. 2000m	Above sea level

Efficiency and Power Loss

AP486.503	typ. 81% / 26W	@ 115V ACin, Iout = 100%
-----------	----------------	--------------------------

Reliability and Lifetime

MTBF (acc. to Siemens standard SN29500)	typ. 200.000 h	115VAC, Iout=100%, T _{amb} =+40°C
Electrolytic capacitors	Only long life (>2.000h/105°C)	
Function test	100% routine test	Test certificate enclosed
In-circuit test	Yes	
Run-in (burn-in)	6 h	Iout=100%, T _{amb} =+55°C

Fuse

The PSU has electronic protection against external short-circuits. In case of an internal defect, a fuse disconnects the unit. It can only be replaced by opening the unit which should be done by the supplier.

Installation for Operating

The unit is constructed for horizontal DIN-rail mounting:

- Connection to mains is located on the bottom side of the unit. For other installation considerations consult your representative.

Ensure free air flow.

Dimensions and Connections

Circuit board with Al/Mg alloy cover on the component side and a plastic cover on the bottom side.

12HP plug in width; for other dimensions see figure and page 1 (subject to change).

Caution:

Do not remove any screws on box, as internal safety connections could be disconnected (consult your representative for details).

Mechanics (Control panel mounting, right side)

Side view

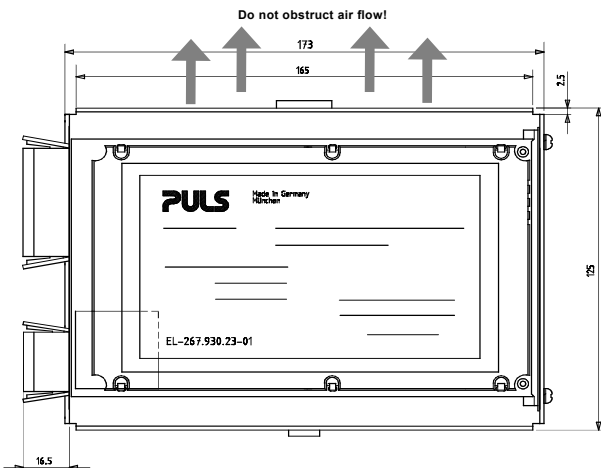

Top view (from the front)

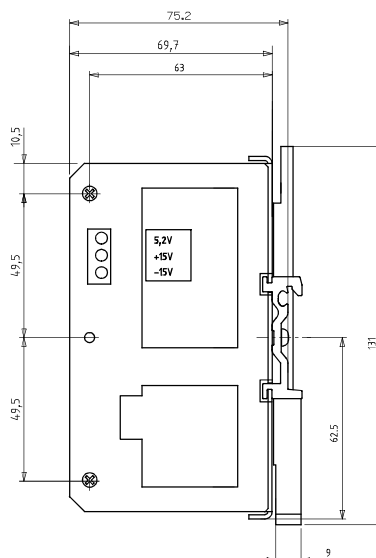

Top view (from above)

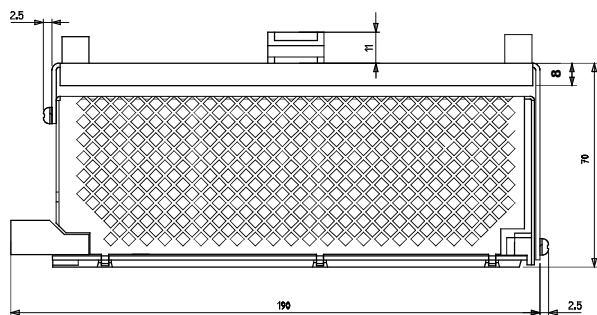

Electrical Schematic

Connection Scheme:

