

# APD336.221/.421

## 3 Outputs

### 19" DC/DC Converter, 50 Watt



- High efficiency: 79% (@ 48V)
- DCin wide range: 9...36V or 18...72V DC
- 8 HP plug in width
- H15 standard pinout
- Active inrush current suppression
- Voltage isolation primary/secondary: 2.5kV
- Flexible load sharing
- Meets EMC standards  
EN 50081-1 (EN 55022/B), EN 50082-2,  
EN 61000-4, VDE 0160/2 and NAMUR



## DC/DC Converter APD336.221/.421

This triple-output, 19" rack-mounting unit has a wide-range DC/DC converter running in bridge mode, so achieving high efficiency across the total load and input range.

The APD336.221/.421 is well suited to supplying 5V digital systems and  $\pm 15V$  analogue systems completely isolated from each other.

EMC compatibility is a major feature. It has low spurious noise, and noise suppression meets VDE 0871 class B. Noise immunity meets EN 61000-4 at the highest levels, even at full load.

Over-voltage and over-temperature protection avoid problems even in extreme operating conditions.

Vout [DC]	Iout	Pout	Features	Order-No.	
Vout1	5.15V	6A	31W	Wide-range input, OTP, OVP	<b>APD336.221</b> (9...36V DC)
2	+15V	2A	30W		
3	-15V	1A	15W		
Max. total power:			50W		
Vout1	5.15V	6A	31W	Wide-range input, OTP, OVP	<b>APD336.421</b> (18...72V DC)
2	+15V	2A	30W		
3	-15V	1A	15W		
Max. total power:			50W		

"F" appended to Order No. means front panel 8 HP included and fitted.

Accessories: H15 connector, 6.3mm flat contacts: **ZP100**  
H15 connector with soldering pins: **ZP120**

Warranty: 2 years from date of delivery.

Schematic:

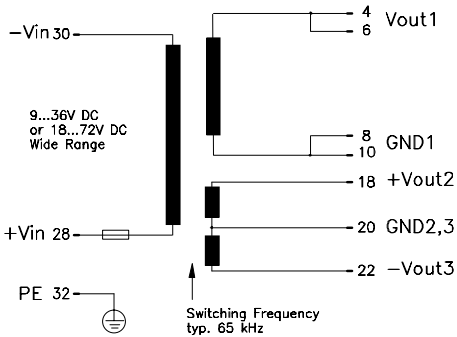

Mechanical: 8HP/3U board (DIN 41494), Al/Mg alloy cover for component side, plastic cover for bottom side, LxWxH = 171.93 x 40.64 x 110mm (100), the length includes the connector, see page 4.

Weight: App. 450g

Connector: H15 (DIN 41612), coding option, max. load per pin 11A @ 70° C.

Output	APD336.221	APD336.421	
Voltage Vout1,2,3			Fixed.
Accuracy Vout1	max. $\pm 0.5\%$	$\pm 0.5\%$	Tuning tolerance without load.
Vout2	$+1,2/-2\%$	$+1,2/-2\%$	As above.
Vout3	max. $\pm 2\%$	$\pm 2\%$	@ Iout3 = 0.5A.
Sense lines	None	None	Not available.
Output power Pout	max. 50W	50W	Total power.
Noise, Ripple Vout1	max. 20mVpp	20mVpp	20Hz...200kHz.
Vout2/3	max. 10mVpp	10mVpp	20Hz...200kHz.
Including spikes Vout1	max. 30mVpp	30mVpp	20Hz...20MHz.
Vout2/3	max. 25mVpp	25mVpp	20Hz...20MHz.
Over-voltage protection	typ. 6.2V	6.2V	For Vout1, threshold accuracy $\pm 8\%$ .
Derating	1.5W/K	1.5W/K	$+55^\circ$ to $+70^\circ$ C Ta.
Operating indicator	1 green LED	1 green LED	On the front, Vout1.
Isolation Vout to Vin	SELV	SELV	EN 60 950, VDE 0805.
Vout1/2 to Vout3	500V AC	500V AC	Test voltage.

All outputs are protected against open-circuit, short-circuit, and overload.

Input	APD336.221	APD336.421	
Line input DC voltage	12/24V DC	24/48/60V DC	Wide-range converter.
• Range	9...36V DC	18...72V DC	Full spec.
DC-input current rms.	max. 8A @ 9V	4A @ 18V	
Noise suppression	EN55 022/B	EN 55 022/B	10kHz...30MHz, conducted.

# APD336.221/.421 · 3 Outputs · 19" DC/DC Converter · 50 Watt

Output (continued)	APD336.221			APD336.421						
	5,15V	+15V	-15V	5,15V	+15V	-15V				
Voltage regulation:										
· Line regulation		max.	%	0.1	2	1.5	0.1	2	1.5	Minimum load....full load, values for Vout2 and Vout3 only valid for Iout1 ≥ 0.5A. 10%...90%...10% load change, values for Vout2 and 3 only valid for Iout1 ≥ 0.5A. Till ΔVout is within <0.5% of final value.
· Load regulation stat.	Δ U <sub>stat</sub>	max.	%	-0.8	-2	-2	-0.8	-2	-2	
· Load regulation dyn.	Δ U <sub>dyn</sub>	max.	%	± 4	± 0.5	± 0.5	± 4	± 0.5	± 0.5	
Response time	t <sub>s</sub>	max.	ms	2			2			
· Temperature coefficient		typ.	%/K	± 0.015			± 0.015			
Ripple		max.	mVpp	20	10	5	20	10	5	
· incl. spikes		max.	mVpp	30	25	20	30	25	20	
Current limitation										
· Threshold		typ.	W	60			60			
· Short-circuit		typ.	A	25	8	2.2	25	8	2.2	
Minimum load			mA	0	0	5	0	0	5	
Start delay	t <sub>Delay</sub>	typ.	s	0.4			0.4			
On and off characteristic				No overshoot			No overshoot			
Load capacity		max.	μF	10,000	2,000	2,000	10,000	2,000	2,000	

## Input (continued)

Input (continued)		APD336.221		APD336.421	
DC input range		V DC	9...36	18...72	Full spec.
Inrush current	typ.	A	6 @ 24V DC	6 @ 60V DC	@ Ta=25°C
	typ.	A	20 @ 24V DC	20 @ 60V DC	@ Ta=70°C
Internal fuse			5x20mm T10A/250V	5x20mm T6.3A/250V	In the +Vin line, as per IEC127/2-5. To replace, see page 4

## Electromagnetic Compatibility

Emissions according to EN 50081-1 Radio interference, EN 55011, EN 55022	Class B	EN 50081-2 is also satisfied
Immunity according to EN 50082-2		EN 50082-1 is also satisfied
· Electrostatic discharge ESD, EN 61000-4-2	8kV direct discharge (level 4) 15kV air discharge (level 4)	
· Radiated fields, EN 61000-4-3	10V/m (level 3)	80MHz...1000MHz, DCin, Vout and signal lines: L=1 m
· Burst, EN 61000-4-4	4kV (level 4) 2kV (level 3) 2kV (level 4) cap. coupling	Coupled to DCin line. Coupled to DCout line. Coupled to Vout and signal lines.
· Surge transients, EN 61000-4-5	2kV (isolation class 3) 1kV (isolation class 3)	Common mode, unit on. Differential mode, unit on.
· Conducted disturb., ENV 50141 (draft of IEC801-6)	10V (level 3)	150kHz...80MHz

Typ. Output Characteristics

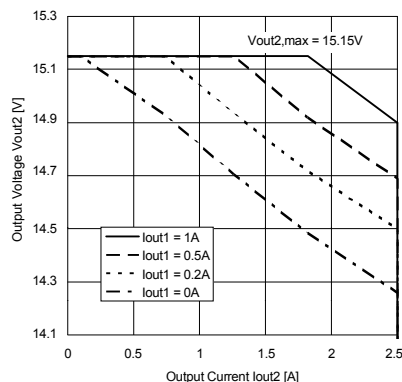

Typ. Derating over Temperature

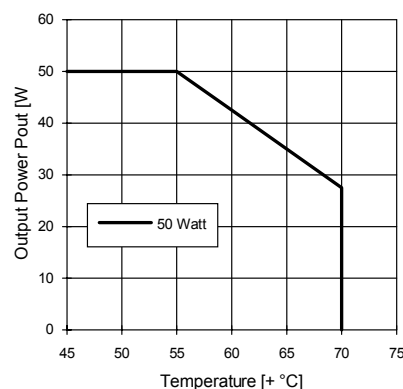

Typ. Efficiency APD336.221

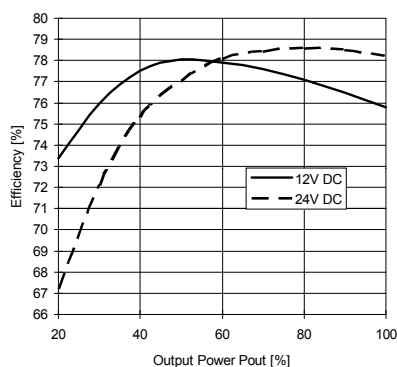

Typ. Efficiency APD336.421

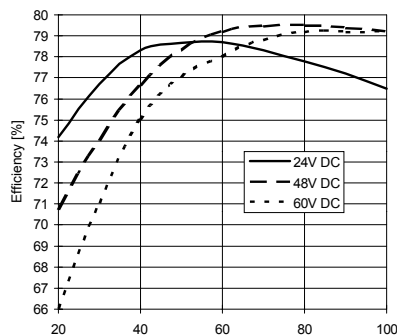

Protection

Unit protection

· Overload	Yes	Total-power limit.
· Short-circuit proof	Yes	
· Open-circuit proof	Yes	
· Over-temp. (OTP)	typ. +100° C	Switch off.
(internal temperature)	typ. +98° C	Switch on.
· Reverse battery prot.	Yes	Unit does not start

Load protection

· Over-voltage (OVP)	Yes	Vout1, switch off.
Threshold	typ. 6.2V	
Accuracy	max. ± 8%	
Restart		Periodic.

Undervoltage protection for APD336.221

· Start up	typ. 10V
· Shut down	8,6V ±4%
· Accuracy	max. ± 6%

Undervoltage protection for APD336.421

· Start up	typ. 19,5V
· Shut down	17,5V ±2,5%

Safety

Electrical safety

· Test voltage (each unit) according to EN 60 950 for t = 2sec	2.5kV AC 2.0kV AC 500V AC	Primary / secondary. Primary / PE. Secondary / PE.
· Air- and leakage distance	3 or 4mm	Primary / secondary.
· Isolation resistance	min. 5MΩ	VDE 0551.
· Protection class	I	VDE 0106 part 1, IEC 536.
· PE resistance	< 0.1Ω	VDE 0805.
· Protection system	IP20	DIN 40050, IEC 529.
· Safe low voltage	SELV	EN 60 950, VDE 0805, VDE 0160.
· Over-voltage class	II	VDE 0110 part 1, IEC 664.

Touch safety

	Finger test	VDE 0100 §6, EN 60 950, VBG4.
· Penetration protection	> Ø 3mm	e.g. screws, small parts etc.

Operation and Ambient Area

Application class	KSF	DIN 40040.
Operation temperature	max. -25° ... +70°C	Ta (measured at 1cm distance).
· Derating range	+55° ... +70°C	Derating.
Storage temperature	typ. -25° ... +100°C	Ta.
Humidity	max. 95%	Non-condensing.
Mechanical usage	Vertical	See page 4.
· Lateral spacing	1HP	To neighbouring units on the component side only, at full load.
Cooling	Normal convection	Don't obstruct air flow.
Dirt protection level	max. 2	VDE 0110 part 1.
Vibration	0.075mm	IEC 68-2-6 (10...60Hz).
Shock	11ms / 15g	IEC 68-2-27 (3 shocks).
Operation height	max. 2,000m	Above sea level.

Efficiency and Power Loss

APD336.221	typ. 77% / 15W	@ 24V DCin, Pout = 50W
APD336.421	typ. 79% / 13W	@ 48V DCin, Pout = 50W

Reliability and Lifetime

MTBF according to Siemens standard SN29500	typ. To be discovered	@12/24V DC (.221) or @ 48V DC (.421), Iout = 100%, +40° C Ta.
Only long life (>2,000h @105° C) electrolytic capacitors are used.		
Function test	100%	Test certificate enclosed.
In-circuit test	Yes	
Run-in (burn-in)	24h	Full load, Ta = +55° C, on/off cycle.

## Fuse

The unit has electronic protection against external short-circuits. In case of an internal defect, a fuse disconnects the unit.

The fuse can be found on the component side of the unit below the label. It can be replaced by using a screw driver.

## Installation for Operating

The unit is constructed for 19" systems:

Ensure that pin 4 of H15 connector is on top. For other installation considerations consult your representative. Ensure free air flow.

## Schematic

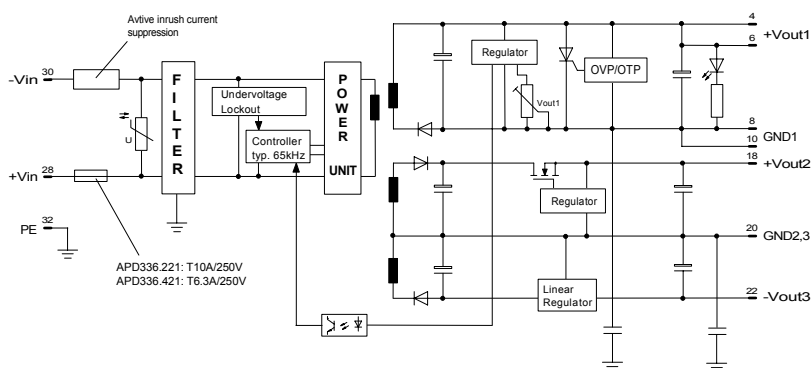

## Dimensions and Connections

19" board, with Al/Mg alloy cover on component side, and a plastic cover on the bottom side. 8HP plug in width.

### Caution:

Do not remove any screws on box, as internal safety connections could be disconnected!

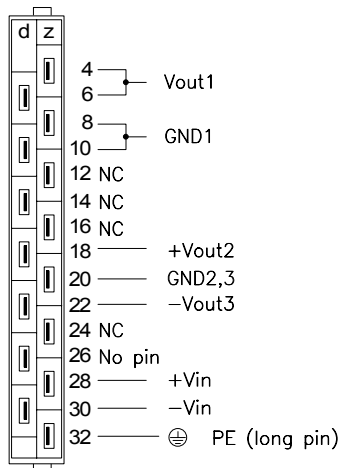

H15 pinout (DIN 41612)

NC = No Connection - Do not use!

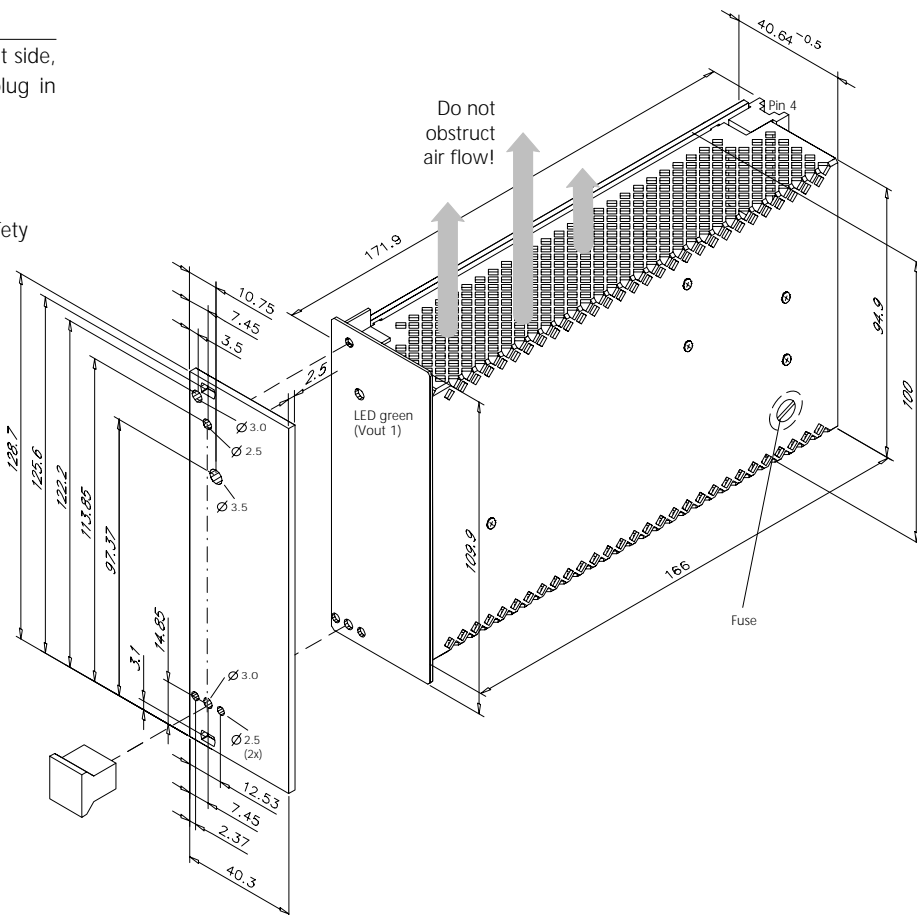

## Modifications (contact supplier)

Lower cost versions.

## Accessory ZP510

Installation set for mounting on DIN rail.