

# DP177

## 1 Output

### DIN Rail Power Supply, 240 Watt

- High efficiency: 88%
- ACin autoselect: 115/230V (@ DP177.102, 104)
- WxHxD = 225x110x130mm
- Parallel mode automatic load sharing
- Over-Temperature Protection (OTP)
- Over-Voltage Protection (OVP)
- Meets EMV standards  
VDE 0160/2, EN 61000-4, NAMUR,  
EN 50081-1 (EN 55022/B) and EN 50082-2
- Design meets VDE 0551



## Power Supply DP177

The DP 177 is a compact solution for applications supplying controllers, sensors, actuators in industrial plants, and heavy machines.

Output voltage is stable over the total load range, and have excellent ripple and noise values below 20mVpp at 24V DC.

Multiple units can supply current in parallel, by connecting their symmetry terminals to ensure each supplies an equal share of the current. Light weight and small size allow quick and easy installation on DIN rails.

Line voltage disturbance and noise immunity satisfies EN 61000-4 and VDE 0160 pulses (class 2 for total load range!). The unit is over-voltage and short-circuit protected. Isolation is equivalent to safety transformers according to VDE 0551, and it meets VBG 4.

Schematic:

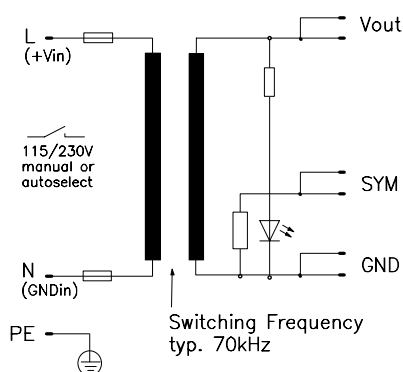

Vout	Iout	Pout	Features	Order-No.
24V	10A	240W	OVP, OTP, parallel mode	DP177.101
24V	10A	240W	OVP, OTP, parallel mode, autoselect	DP177.102
28V	8.5A	238W	OVP, OTP, parallel mode	DP177.103
28V	8.5A	238W	OVP, OTP, parallel mode, autoselect	DP177.104
48...60V	4A	240W	OVP, OTP, parallel mode, autoselect	DP177.105

Warranty: 2 years from date of delivery.

### Output

Voltage Vout adjustable	min. ± 5%	DP177.101 ... DP177.104
	min. 48...60V	DP177.105
Accuracy	max. ± 1%	Includes: production-adjustment, line regulation, and load regulation.
Sense lines	None	Not available.
Minimum load	None	Not necessary.
Output power Pout	max. 240W	With single or parallel operation.
Noise, Ripple incl. spikes	max. 50mVpp	20Hz...200kHz.
	max. 100mVpp	20Hz...20MHz.
Over-voltage protection		
DP177.101, 102	typ. 26.4V	Threshold accuracy ± 4%.
DP177.103, 104	typ. 30.8V	Threshold accuracy ± 3%.
DP177.105	typ. 66.0V	Threshold accuracy ± 2%.
Derating	6W/K	+55° to +70°C Ta.
Operating indicator	1 green LED	Seen through grill, see page 4.
Isolation Vout to Vin	SELV	EN 60 950, VDE 0805.
The output is protected against open-circuit, short-circuit, and overload.		

### Input

Mechanical:	Al/Mg alloy housing, snap-on mounting for DIN rail TS35/7.5 (EN 50 022), WxHxD = 225 x 110 x 130mm, the depth includes the DIN-rail mounting, see page 4.
Weight:	App. 1360g
Screw terminals:	Input 1 terminal, max. 2.5mm <sup>2</sup> , output 2 terminals, each max. 2.5mm <sup>2</sup> , see page 4.

Line input AC 1	100...127V AC	Bridge operation for 115V.
	110...120V AC	Units with ACin autoselect
• Range	92...132V AC	Full spec.
	80...92V AC	Derated, see page 2.
Line input AC 2	220...240V AC	230V-operation.
• Range	184...264V AC	Full spec.
	150...184V AC	Derated, see page 2.
Line frequency	47...63Hz	DC or 400Hz, see page 2.
Input current rms.	max. 4.0Aeff. / 1.8Aeff.	@ 115 / 230V AC.
Noise suppression	EN 55 022/B	10kHz...30MHz, conducted.

# DP177 · 1 Output · DIN Rail Power Supply · 240 Watt

Output (continued)				.101	.103		
DP177.				.102	.104	.105	
Voltage regulation:							
· Line regulation		max.	%	± 0.02	± 0.02	± 0.02	92...132V AC / 184...264V AC, I <sub>out</sub> = 100%.
· Load regulation stat.	Δ U <sub>stat</sub>	max.	%	± 0.1	± 0.1	± 0.1	I <sub>out</sub> = 50%, Δ I <sub>out</sub> = ±50%.
· Load regulation dyn.	Δ U <sub>dyn</sub>	max.	%	± 2	± 2	± 2	Δ I <sub>out</sub> = 10%...90%...10%, rise time dt = typ. 20μs.
Response time	t <sub>s</sub>	max.	μs	500	500	500	Till ΔV <sub>out</sub> is within < 0.5% of final value.
· Temperature coefficient		typ.	%/K	± 0.01	± 0.01	± 0.01	
Ripple		max.	mVpp	50	50	50	20Hz...200kHz, @AC nom, I <sub>out</sub> = 100%.
· incl. spikes		max.	mVpp	100	100	100	20Hz...20MHz, @AC nom, I <sub>out</sub> = 100%.
Current limitation							
· Threshold		min/max.	A	105% ... 130% of I <sub>out</sub>			Fixed.
· Characteristic				See graph on page 3			
· Short-circuit		max.	A	140% of I <sub>out</sub>			
Start delay	t <sub>Delay</sub>	typ.	ms	400	400	400	@ 115V AC
	t <sub>Delay</sub>	typ.	ms	30	30	30	@ 230V AC
V <sub>out</sub> rise-up time	t <sub>Rise</sub>	typ.	ms	70	70	70	
On and off characteristic							
Power back immunity	U <sub>Back</sub>	max.	V	1.2xV <sub>out</sub>	1.2xV <sub>out</sub>	—	Approximately monotonic. Unit off/on.

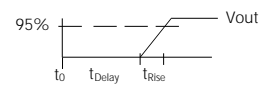
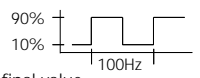

## Input (continued)

AC input range 1 / 2	V AC	92...138 / 184...264	Full spec.
DC input range	V DC	250...300	Full spec, for autoselect operation take the polarity into consideration.
Derated AC range 1 / 2	V AC	80...92 / 150...184, 150 / 300 for 0.5s	No start below 92V AC / 184V AC
Derated DC range	V DC	170...250	Power derating typ. 10%, no start below 250V DC.
	V DC	300...370	Full spec, but air- and leakage distances not longer than stated in VDE 0805.
Frequency range	Hz	47...63	Full spec.
Derated frequency range	Hz	63...440	Increased leakage currents.
In-rush current	max.	A	@ 230V AC, wait min. 30s before switching on again (cold-start), NAMUR standard met (T <sub>a</sub> = 25° C).
Hold-up time	min.	ms	17
	min.	ms	20
Power factor λ	typ.	0.60	@ 92V AC, I <sub>out</sub> = 100%.
Internal fuse		5x20mm T4A/250V	L and N, as per IEC 127/2-5. To replace, see page 4.
Input range selection DP177.101, 103, 105 DP177.102, 104		Manual (230V AC set at factory) Automatic	Set a bridge between Y1 and Y2 for 115V-operation.

## Logic Functions

Parallel operation	max.	10 units	
· Current distribution		Equal	Characteristic see page 3.
· Connection		Connect SYM-terminals	Use equal-length output cables.
V <sub>out</sub> adjustable DP177.101 ... 104	min.	%	± 5 ± 5
V <sub>out</sub> adjustable DP177.105	min.	V	48...60
			Trimmer position see page 4.

## Electromagnetic Compatibility

Emissions according to 50081-1		EN 50081-2 is also satisfied
· Radio interference, EN 55011, EN 55022	Class B	Conducted 10kHz...30MHz.
Immunity according to 50082-2		EN 50082-1 is also satisfied
· Electrostatic discharge ESD, EN 61000-4-2	8kV direct discharge (level 4) 15kV air discharge (level 4)	
· Radiated fields, EN 6100-4-3	10V/m (level 3)	ACin, V <sub>out</sub> and SYM lines: length = 1m.
· Fast transients, EN 61000-4-4	4kV (level 4) 2kV (level 3) 2kV (level 4) cap. coupling	Coupled to ACin line. Coupled to DCout line. Coupled to V <sub>out</sub> and SYM lines.
· Surge transients, EN 61000-4-5	4kV (isolation class 4) 2kV (isolation class 4) 5kV	Common mode, unit on. Differential mode, unit on. Common mode, unit off.
· Transient voltage, IEC 255	Satisfied	
· NAMUR-prescription	750V / 1.3ms (class 2)	Valid for total load range.
· Transient resistance, VDE 0160 §5.3.1.1.2	150/300V AC / 0.5s	
· Over-voltage resistance (PULS standard)		

## Minimum Hold-Up Time

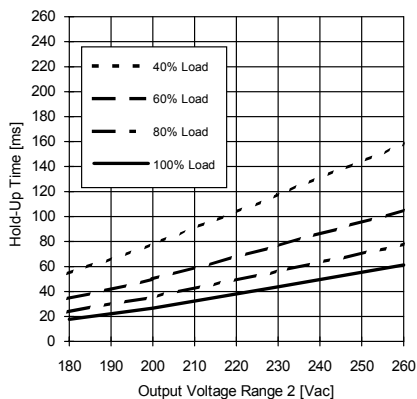

## Typ. Output Characteristic

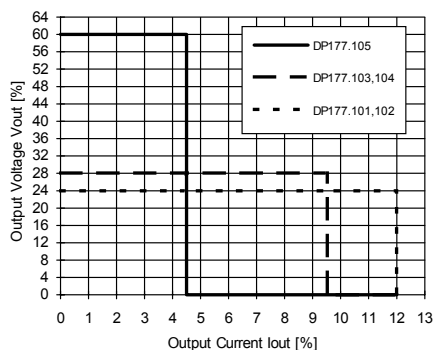

## Typ. Derating over Temperature

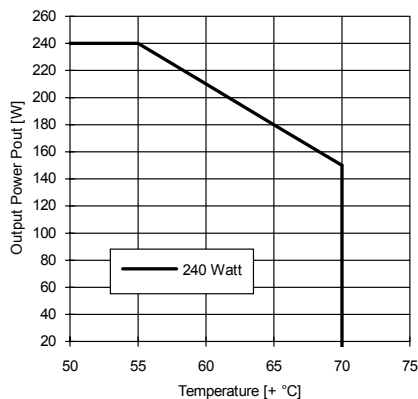

## Typ. Efficiency

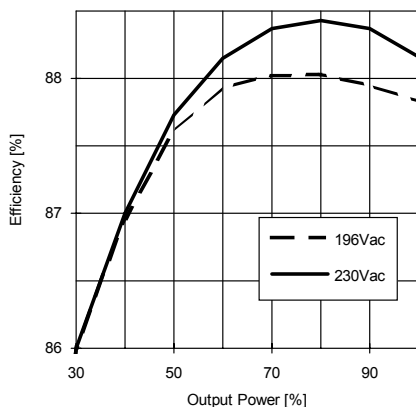

## Protection

### Unit protection

· Overload	Yes	See current limit.
· Short-circuit proof	Yes	Automatic voltage recovery.
· Open-circuit proof	Yes	
· Over-temperature (OTP)	100° C int. temp.	Switch-off.
· Reverse battery prot.	Yes	DP177.101, 103, 105
· ACin range selection	Manual	DP177.101, 103, 105
	Autoselect	DP177.102, DP177.104.

### Load protection

· Over-voltage (OVP)	Yes	
Threshold	typ. 26.4V	max. ± 4% DP177.101, DP177.102.
	typ. 30.8V	max. ± 3% DP177.103, DP177.104.
	typ. 66.0V	max. ± 2% DP177.105.

## Safety

### Electrical safety

· Test voltage (each unit) according to EN 60 950 for t = 2sec	3kV AC	Primary / secondary.
	2.5kV AC	Primary / PE.
	500V AC	Secondary / PE.
· Air- and leakage distance	8mm	Primary / secondary.
	4mm	Primary / PE.
· Isolation resistance	min. 5MΩ	VDE 0551.
· Protection class	I	VDE 0106 part 1, IEC 536 .
· PE resistance	< 0.1Ω	VDE 0805.
· Protection system	IP20	DIN 40050, IEC 529.
· Leakage current	max. 0.75mA	EN 60 950 (47...63Hz line) .
· Safe low voltage	SELV	EN 60 950, VDE 0805, VDE 0160.
· Over-voltage class	II	VDE 0110 part 1, IEC 664.

### Touch safety

Finger test	VDE 0100 §6, EN 60 950, VBG4.
-------------	-------------------------------

### Penetration protection

> Ø 3mm	e.g. screws, small parts etc.
---------	-------------------------------

## Operation and Ambient Area

Application class	KSF	DIN 40040.
Operation temperature	max. 0° ... +70°C	Ta (measured at 1cm distance).
· Derated range	+55° ... +70°C	Derating, see diagram.
Storage temperature	typ. -20° ... +100°C	Ta.
Humidity	max. 95%	Non-condensing.
Mechanical usage	See page 4	
· Distance to cable channels	See page 4	
· Lateral spacing	None	No gap needed.
Cooling	Normal convection	Don't obstruct air flow.
Dirt protection level	max. 2	VDE 0110 part 1.
Vibration	0.075mm	IEC 68-2-6 (10...60Hz).
Shock	11ms / 15g	IEC 68-2-27 (3 shocks).
Operation height	max. 2,000m	Above sea level.

## Efficiency and Power Loss

DP177.101 ... 105	typ. 88% / 33W	@ 230V ACin, Iout = 100%.
-------------------	----------------	---------------------------

## Reliability and Lifetime

MTBF according to Siemens standard SN29500	typ. 200,000h	230VAC, Iout = 100%, +40°C Ta.
Only long life (> 2,000h @105° C) electrolytic capacitors are used.		
Function test	100%	Test certificate enclosed.
In-circuit test	Yes	
Run-in (burn-in)	24h	Full load, Ta = +55° C, on/off cycle.

# DP177 · 1 Output · DIN Rail Power Supply · 240 Watt

## Fuse

The PSU has electronic protection against external short-circuits. In case of an internal defect, a fuse disconnects the unit. It can only be replaced by opening the unit which should be done by the supplier.

## Installation for Operating

Install DIN rail TS35/7.5 horizontally, ensuring correct orientation.

For other installation considerations consult your representative. Ensure free air flow.

## Dimensions and Connections

Fully enclosed Al/Mg alloy housing.  
All mechanical dimensions are in mm.

h	s (min)	
38mm	15mm	= e.g. KL25/35
66mm	30mm	= e.g. KL25/60

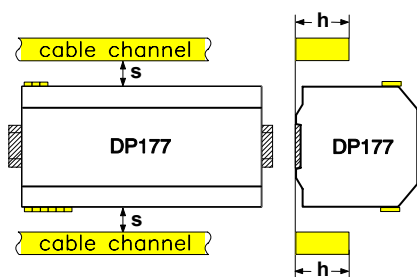

Required mounting dimensions

## Schematic

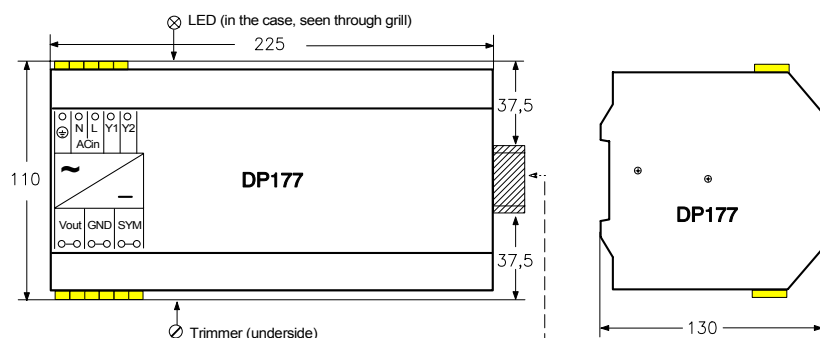
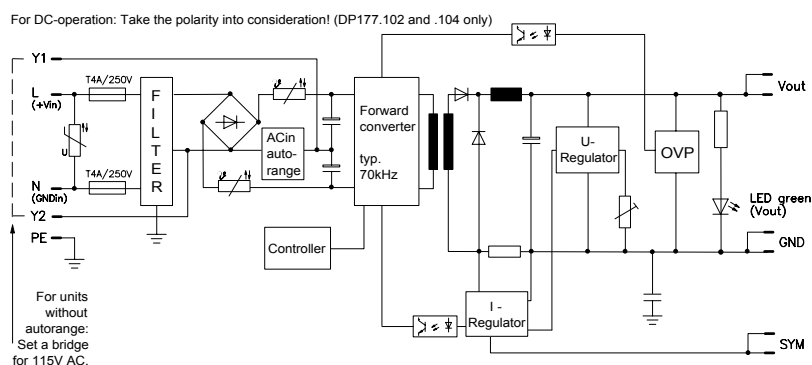

Weight: typ. 1360g

Snap the unit direct on the DIN rail TS35/7.5!

Install DIN rail horizontally. For vertical installation contact PULS.

The width of 225mm includes the lateral case screws.

Do not remove any screws on box, as internal safety connections could be disconnected!

## Connections at alternating voltage

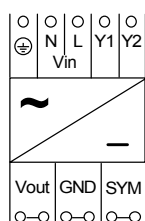

Screw terminals:

max. 2.5mm<sup>2</sup> cross section

Take care of standards which must be satisfied, e.g. VDE 0100 or EN 60950.

Y1 and Y2 only for DP177.101, .103, .105

## Connections at direct voltage

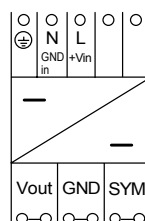

## Modifications (contact supplier)

Negative temperature co-efficient for battery loads.

Other DC input voltage ranges.

Other output voltage ranges.

Lower cost versions.