

DPA247

2 Outputs with AS-Interface data decoupling

DIN Rail Power Supply, 244 Watt

- High efficiency: 89%
- ACin 115/230V manual switch
- WxHxD = 120x134x120mm
- Two electrically insulated outputs
- Each output with AS-interface data decoupling
- Meets EMC standards: EN 50081-1, EN 50082-2, NAMUR, EN 61000-4, VDE 0160/2
- Design meets VDE 0551
- Both outputs with double terminals



Figure shows a similar unit (see page 4)

Preliminary data sheet Power Supply DPA247

The DPA247 is a very compact power supply designed for fieldbus applications in which power and data share the same twisted-pair (AS-interface specification).

At two electrically insulated outputs, the unit supplies power, decouples data from the power supply, and makes the two cables of each output (AS-i + and AS-i -) symmetrical with respect to the shield terminal. The decoupling allows the use of un-shielded cables.

The PELV output circuit has electronic protection against overload and short-circuit. Isolation is equivalent to safety transformers as specified in VDE 0551.

Vout	Iout	Pout	Features	Order-No.	
Vout1	30.55V	4A	122W	OVP, AS-Interf. data decoupling	DPA247.141
Vout2	30.55V	4A	122W	OVP, AS-Interf. data decoupling	

Warranty: 2 years from date of delivery.

Schematic

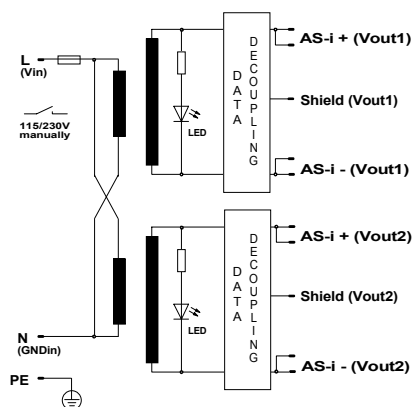

Output

Voltage Vout1	30.55V	Fixed.
Vout2	30.55V	Fixed.
Accuracy	max. ± 3%	includes: production-adjustment, line regulation, and load regulation.
Minimum load	None	Not necessary.
Output power Pout	max. 244W	Mounting side by side possible.
Noise, Ripple	max. 50mVpp	0...20MHz, constant current or R-load.
Modulation voltage	max. 5.6Vrms	Analogous 16Vpp sine.
Over-voltage protection	typ. 35V	Threshold accuracy ± 4%.
Derating	5W/K	+60° bis +70°C Ta.
Operating indicator	2 green LEDs	On the front, lighting at Vout>30V
Output circuit	PELV	VDE 0106.
Safety		VDE 0106, EN 60 950, VDE 0805.
Isolation Vout1 against Vout2 max. 500 VAC		
All outputs are protected against open-circuit, short-circuit, and overload.		

Input

Line input 1	100...127V AC	Switch position 115V.
• Range	88...132V AC	Full spec.
	80...150V AC	Derated, see page 2.
Line input 2	220...240V AC	Switch position 230V.
• Range	176...264V AC	Full spec.
	150...300V AC	Derated, see page 2.
Line frequency	47...63Hz	DC or 400Hz, see page 2.
Input current	max. 6.0Aeff. / 2.8Aeff.	@ 115 / 230V AC.
Noise suppression	EN 55 022/B and FCC/B	

Mechanical: Al/Mg alloy housing, snap-on mounting for DIN rail TS35/7.5 (EN 55022), WxHxD = 120 x 134 x 120mm, the depth includes the DIN-rail mounting, see page 4.

Weight: App. 1150g

Screw terminals: Input 1 terminal, max. 2.5/4mm²
Output 2 terminals, each max. 2.5/4mm², see page 4

DPA247 · 2 AS-i Outputs · DIN Rail Power Supply · 244 Watt

Output (continued)

Voltage regulation:

· Line regulation		max.	%	± 0.2
· Load regulation stat.	ΔU_{stat}	max.	%	± 0.5
· Temperature coefficient		typ.	%/K	± 0.02

Ripple max. mVpp 50

Current limitation

· Threshold		min/max.	A	4.2 / 6.5
· Characteristic				See graph on page 3
· Short-circuit				8.5

Start delay t_{Delay} typ. ms 150

Vout rise-up time t_{Rise} typ. ms 350

On and off characteristic

Vout1, Vout2

88...132V AC / 187...264V AC, Pout = 240W.
Iout = 50%, D Iout = ±50%.

0...20MHz, @ ACnom, Iout = 100%, R or I-load.

Fixed, 29V Z-load

lowering with increasing temperature

After switch on (to).

Load 4A and C-load 15mF.

Approximately monotonic

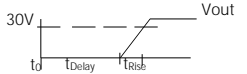

Input (continued)

AC input range 1 / 2		V AC	88...132 / 176...264	Full spec.
DC input range		V DC	210...375	Full spec., input voltage selector must be in 230V pos.!
Derated AC range 1 / 2		V AC	80...88 / 150...187, 150 / 300 for 0.5s	
Frequency range		Hz	47...63	Full spec.
Derated frequency range		Hz	63...400	Increased leakage currents.
In-rush current		max. A	80	@ cold-start and 264V AC, NAMUR standard met (Ta = 25° C).
Hold-up time		min. ms	10	@ 88/176V AC, Pout = 240W, see fig. on page 3.
Power factor λ		typ.	0.6	@ 88V AC, Pout = 244W.
Internal fuse			5x20mm T8A/250V (IEC127/2-5)	To replace, see page 4.
Input range selection			Manual	115/230V switch, position see page 4

Data Decoupling / Earth Symmetrization

Output inductance	100µH ± 10%	According to AS-Interface-specifications
Terminating impedance	2 x 39Ω ± 1%	Measured between AS-i + und AS-i - .
Symmetry tolerance	± 1%	As above.
Electric strength	500V	AS-i + / AS-i - to shield.
		As above.

Electromagnetic Compatibility

Emissions according to EN 50081-1		EN 50081-2 is also satisfied.
· Radio interference, EN 55011, EN 55022, FCC	Class B	
Immunity according to EN 50082-2	No degradation of performance	EN 50082-1 is also satisfied.
· Electrostatic discharge ESD	8kV direct discharge (level 4)	
EN 61000-4-2	15kV air discharge (level 4)	
· Radiated fields, EN 61000-4-3	10V/m (level 3)	80MHz...1000MHz, ACin and Vout lines: l = 1m.
· Fast transients, EN 61000-4-4	4kV (level 4)	asym. and unsym. coupled to ACin line.
	2kV (level 3)	asym. and unsym. coupled to DCout line.
· Surge transients EN 61000-4-5	4kV (isolation class 4)	Common mode (L -> PE, N -> PE), unit on.
	2kV (isolation class 4)	Differential mode (L -> N), unit on.
· Conducted disturb., EN 61000-4-6	10V (level 3)	150kHz...80MHz.
Immunity according to further standards		
· Transient voltage, IEC 255	5kV	Common mode (L and N -> PE), unit off.
· NAMUR-prescription	Satisfied	
· Transient resistance, VDE 0160 §5.3.1.1.2	750V / 1.3ms (class 2)	Valid for total load range.

Typ. Output Characteristic Vout1/Vout2

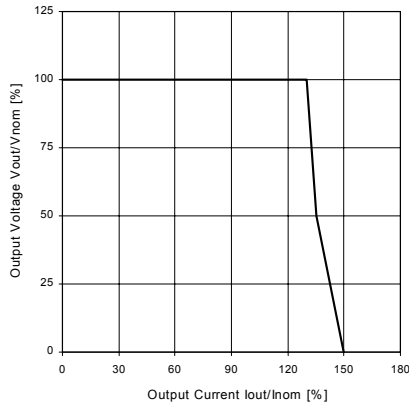

Protection

Unit protection

· Overload	Yes	See current limitation*.
· Short-circuit proof	Yes	Automatic voltage recovery*.
· Open-circuit proof	Yes	
· Over-temperature (OTP)	Yes	Separately for each converter (output).
· Reverse battery prot.	Yes	
· ACin range selection	Manual	Switch for 115/230V AC. * no Hiccup

Load protection

· Over-voltage (OVP)	Yes	Independant second regulator.
Threshold	typ. 35V	
Accuracy	max. ± 4%	

Typ. Efficiency

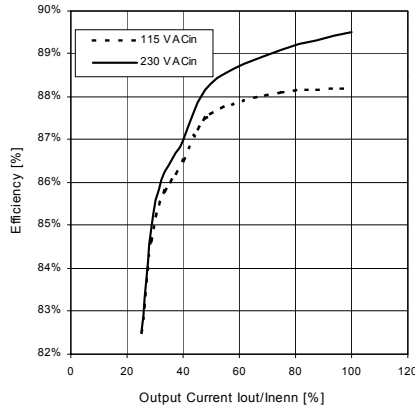

Safety

Electrical safety

· Test voltage according to EN 60 950 for t = 2sec	3kV AC 2.5kV AC 500V AC	Primary / secondary. Primary / PE. Secondary / PE.
· Air- / leakage distance	6.4 / 8mm 4mm	Primary / secondary. Primary / PE.
· Isolation resistance	min. 5MΩ	VDE 0551.
· Protection class	I	VDE 0106 part 1, IEC 536.
· PE resistance	< 0.1Ω	VDE 0805.
· Protection system	IP20	DIN 40050, IEC 529.
· Leakage current	max. 0.75mA	EN 60 950 (50Hz frequency line).
· Output circuit	PELV	VDE 0160.
· Over-voltage class	II	VDE 0110 part 1, IEC 664.

Touch safety

Penetration protection	Finger test > Ø 3mm	VDE 0100 §6, EN 60 950, VBG4. e.g. screws, small parts etc.
------------------------	------------------------	--

Typ. Derating over Temperature

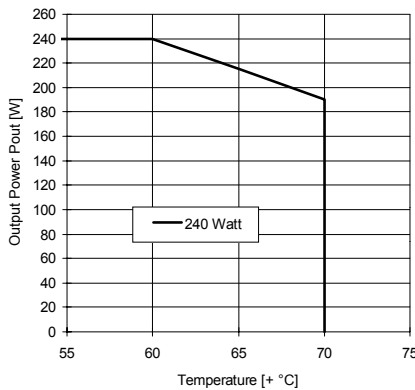

Operation and Ambient Area

Application class	KSF	DIN 40040.
Operation temperature	max. -10° ... +70°C	Ta (measured at 1cm distance).
· Derated range	+60° ... +70°C	Derating, see diagram.
Storage temperature	typ. -20° ... +100°C	Ta.
Humidity	max. 95%	Non-condensing.
Mechanical usage	Vertical	See page 4.
· Lateral spacing	None	No gap needed.
Cooling	Normal convection	Don't obstruct air flow.
Dirt protection level	max. 2	VDE 0110 part 1.
Vibration	0.075mm	IEC 68-2-6 (10...60Hz).
Shock	11ms / 15g	IEC 68-2-27 (3 shocks).
Operation height	max. 2,000m	Above sea level.

Min. Hold-up Time

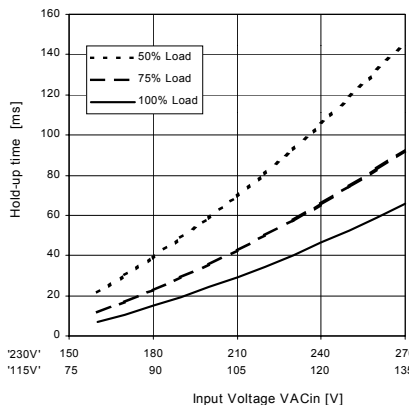

Efficiency / Loss

100% load	typ. 89% / 30W	@ 230V ACin.
Loss with no load	typ. 4 W	

Reliability and Lifetime

MTBF according to Siemens standard SN29500	typ. 200,000h	230VAC, Iout =100%, +40°C Ta.
Only long life (> 2,000h @105° C) electrolytic capacitors are used.		
Function test	100%	Test certificate enclosed.

DPA247 · 2 AS-i Outputs · DIN Rail Power Supply · 244 Watt

Fuse

The PSU has electronic protection against external short-circuits. In case of an internal defect, a fuse disconnects the unit. It can only be replaced by opening the unit which should be done by the supplier.

Installation for Operating

Install DIN rail TS35/7.5 horizontally, ensuring correct orientation.
For other installation considerations consult your representative. Ensure free air flow.

Dimensions and Connections

Fully enclosed Al/Mg alloy housing. All mechanical dimensions are in mm.

1) Do not remove PE screws.

The shield terminal should be connected to earth or to the shield of the load cable.

Screw terminals:

On the front side. These accept wire of up to 4mm² cross section (single-core cable) or 2.5mm² cross section (multi-core flex).
Remove 9 to 15mm of insulation from wire.
Take care of standards which must be satisfied, e.g. VDE 0100 or EN 60 950.

Caution:

Do not remove any screws on box, as internal safety connections could be disconnected!

Operation without AS-Interface

When operating without AS-Interface (e.g. in a lab. test) you should connect a 470µF capacitor between AS-i + and AS-i -, because commercial lab-loads often tend to oscillate. They may resonate with the data decoupling, and the oscillations may exceed the permitted modulation voltage.

Modifications (contact supplier)

Other output voltages,
OEM-versions.

Schematic

