

DPD155

1 Output

DIN Rail DC/DC Converter, 120 Watt



- High efficiency: 85%
- DCin wide range: 19.2...32V DC or 48/60V DC (@ DPD155.331)
- WxHxD = 74x130x120mm
- Parallel mode automatic load sharing (@ DPD155.133 and DPD155.134)
- Voltage isolation primary/secondary: 2.5kV
- Self-diagnostic LED and ready contact (RDY)
- Meets EMV standards EN 61000-6-2, EN 61000-6-3 NAMUR, VDE 0160/2



US (not for DPD155.331)

DC/DC Converter DPD155

The DPD155 is designed to supply up to 5A at 24V. Output voltage is stable with ripple and noise below 25mVpp over the total range up to 120W.

The high-efficiency flyback converter gives greater reliability and economy. Multiple units can be used in parallel to increase system power without extra control wiring, as the current is automatically shared between units (DPD155.133 and DPD155.134 only).

The design is immune to input disturbances according to EN 61000-4-X, and VDE 0160 pulse (class 2 over the entire load range!).

The unit is also protected against overvoltage and short-circuits. Construction and design meet all relevant safety standards, such as EN 60 950, VDE 805, VBG 804 and EN 55 022/B.

Schematic:

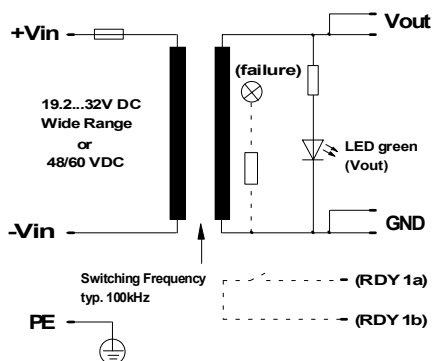

Vout	Iout	Pout	Features	Order-No.
24V	5A	120W	OVP	DPD155.131
24V	5A	120W	OVP, parallel mode	DPD155.133
24V	5A	120W	OVP, parallel mode, RDY, Error-LED	DPD155.134
24V	5A	120W	OVP, 48/60 VDC input	DPD155.331

Warranty: 2 years from date of delivery.

Output

Voltage Vout	Accuracy	DPD155.131, 331	max. ± 2%	Fixed.
		DPD155.133, 134	max. ± 5%	Includes: production-adjustment, line regulation, and load regulation.
Sense lines			None	Not available.
Minimum load			None	Not necessary.
Output power Pout		DPD155.133 only	max. 120W	Mounting side by side possible.
			max. 96W	Per unit (@ parallel operation).
Noise, Ripple incl. spikes			max. 20mVpp	20Hz...200kHz (@ 24V DC).
			max. 25mVpp	20Hz...20MHz (@ 24V DC).
Over-voltage protection			typ. 1.2 x Vout	Threshold accuracy ± 4%.
Derating			2W/K	+60° to +70°C Ta.
Operating indicator			1 green LED	On the front.
Isolation Vout to Vin			2.5kV / 4mm	Air- and leakage distance.
The output is protected against open-circuit, short-circuit, and overload.				

Mechanical: Al/Mg alloy housing, snap-on mounting for DIN rail TS35/7.5 (EN 50 022), WxHxD = 74 x 130 x 120mm, the depth includes the DIN-rail mounting, see page 4.

Weight: App. 730g

Screw terminals: Input 1 terminal, max. 2.5/4mm², output 2 terminals, each max. 2.5/4mm², see page 4.

Input

Line input DC	DPD155.131/133/134	• Range	19.2...32V DC	Full spec.
			12...19.2V DC	Derated.
	DPD155.331	• Range	48 / 60 V DC	Full spec.
			30...80 V DC	Full spec.
DC-input current		max.	7A	@ 24V DC (DPD155.13x)
		max.	4.5A	@ 48V DC (DPD155.331)
Noise suppression			EN 55 022/B	

Specifications are subject to change without prior notice.

DPD155 · 1 Output · DIN Rail DC/DC Converter · 120 Watt

Output (continued)		DPD155.	.131	.133	.134	.331		
Voltage regulation:								
· Line regulation		max.	%	± 0.2	± 0.2	± 0.2	± 0.5	@ U _{in} as specified, I _{out} = 100%.
· Load regulation stat.	Δ U _{stat}	max.	%	± 0.5	± 4	± 4	± 0.5	I _{out} = 50%, Δ I _{out} = ± 50%.
· Load regulation dyn.	Δ U _{dyn}	max.	%	± 0.5	± 2.5	± 2.5	± 0.5	Δ I _{out} = 10%...90%...10%, rise time dt = typ. 20μs. Till ΔV _{out} is within < 0.5% of final value.
Response time	t _s	max.	μs	800	2200	2200	800	
· Temperature coefficient		typ.	%/K	± 0.01	± 0.01	± 0.01	± 0.01	
Ripple		max.	mVpp	20	20	20	20	20Hz...200kHz, @ DC nom, I _{out} = 100%.
· incl. spikes		max.	mVpp	25	25	25	25	20Hz...20MHz, @ DC nom, I _{out} = 100%.
Current limitation								
· Threshold		min/max.	A	105% ... 170% of I _{out}				Fixed.
· Characteristic				See graph on page 3				
· Short-circuit		max.	A	250% of I _{out}				Pulsed.
Start delay	t _{Delay}	typ.	ms	500				After switch on.
V _{out} rise-up time	t _{Rise}	typ.	ms	20				

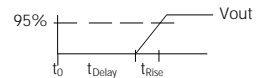
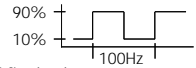

Input (continued)		DPD155.	.131/.133/.134	.331	
DC input range		V DC	19.2 ... 32	30...80	Full spec.
Derated DC range		V DC	12 ... 19.2	—	
In-rush current	max.	A	85	75	NAMUR standard met (T _a = 25° C).
Hold-up time at Vin-failure	min.	ms	20	—	See diagram on page 3.
Internal fuse			30A/32V	F10A/250V	To replace, see page 4.

Logic Functions		DPD155.	.131	.133/.134	.331		
Parallel operation, DPD155.133 and .134 only		units	—	Unlimited	—	No limit of number of units for DPD155.133, 134.	
· Current distribution			—	Equal	—	Characteristic see page 3.	
· Connection			No additional wiring needed.			Use equal-length output cables.	
Self diagnostic "Error-LED"			Cond.	Red LED	Green LED	RDY-contact	
Ready contact "RDY"			Fail	Off	Off	Open	Malfunction, send unit to supplier
			Overload, Load in short-circuit	On	Off	Open	Check load and/or DC/DC converter
			Operation	Off	On	Closed	Normal operation

Electromagnetic Compatibility

Emissions according to EN 61000-6-3					EN 61000-6-4 is also satisfied.
· Radio interference, EN 55011, EN 55022			Class B		
Immunity according to EN 61000-6-2			No degradation of performance		EN 61000-6-1 is also satisfied.
· Electrostatic discharge ESD			8kV direct discharge (level 4)		
EN 61000-4-2)			15kV air discharge (level 4)		
· Radiated fields, EN 61000-4-3			10V/m (level 3)		80MHz...1000MHz, DCin, Vout and signal lines: l = 1m.
· Fast transients, EN 61000-4-4			4kV (level 4)		Coupled to DCin line.
			2kV (level 3)		Coupled to DCout line.
			2kV (level 4) cap. coupling		Coupled to Vout and signal lines.
· Surge transients, EN 61000-4-5			2kV (isolation class 3)		Common mode, unit on.
			1kV (isolation class 3)		Differential mode, unit on.
· Conducted disturb., ENV 61000-4-6			10V (level 3)		150kHz...80MHz.
Immunity according to further standards					
· NAMUR-prescription			Satisfied		

Min. Hold-Up Time at Vin-failure
(DPD155.13x)

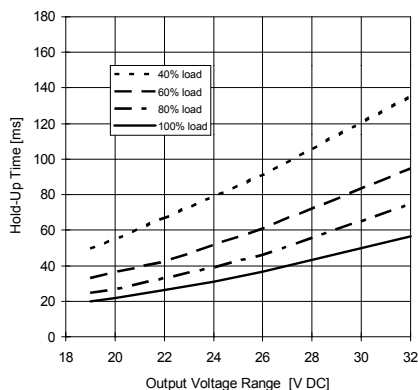

Typ. Output Characteristic

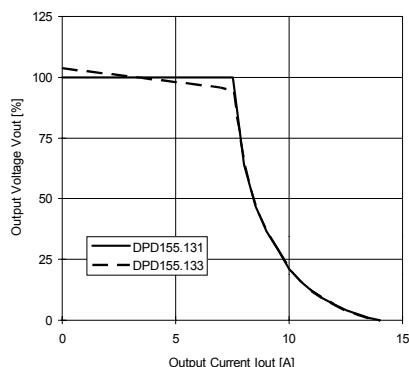

Typ. Derating over Temperature

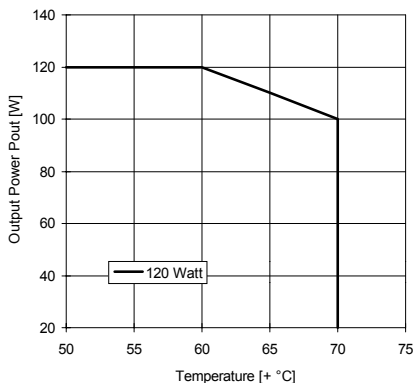

Typ. Efficiency (DPD155.13x)

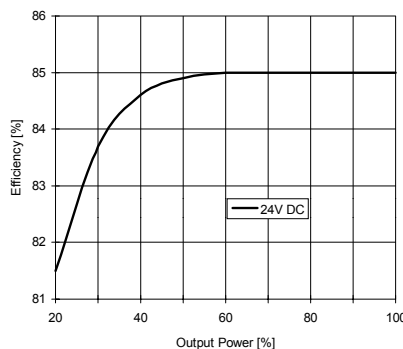

Protection

Protection Type	Feature	Value	Notes
Unit protection	· Overload	Yes	See current limit.
	· Short-circuit proof	Yes	Automatic voltage recovery.
	· Open-circuit proof	Yes	
	· Over-temperature (OTP)	—	
	· Reverse battery prot.	Yes	
Load protection	· Over-voltage (OVP)	Yes	
	Threshold	typ. 29.0V	
	Accuracy	max. ± 4%	
	Method		Independent second regulator.

Safety

Electrical safety	Value	Notes
· Test voltage (each unit)	2.5kV AC	Primary / secondary.
	2.5kV AC	Primary / PE.
	500V AC	Secondary / PE.
· Air- and leakage distance	4mm	Primary / secondary.
	4mm	Primary / PE.
· Isolation resistance	min. 5MΩ	VDE 0551.
· Protection class	I	VDE 0106 part 1, IEC 536 .
· PE resistance	< 0.1Ω	VDE 0805.
· Protection system	IP20	DIN 40050, IEC 529.
· Over-voltage class	II	VDE 0110 part 1, IEC 664.
Touch safety	Finger test	VDE 0100 §6, EN 60 950, VBG4.
Penetration protection	> Ø 3mm	e.g. screws, small parts etc.

Operation and Ambient Area

Parameter	Value	Notes
Application class	KSF	DIN 40040.
Operation temperature	max. 0° ... +70°C	Ta (measured at 1cm distance).
· Derated range	+60° ... +70°C	Derating, see diagram.
Storage temperature	typ. -20° ... +100°C	Ta.
Humidity	max. 95%	Non-condensing.
Mechanical usage	Vertical	See page 4.
· Lateral spacing	None	No gap needed.
Cooling	Normal convection	Don't obstruct air flow.
Dirt protection level	max. 2	VDE 0110 part 1.
Vibration	0.075mm	IEC 68-2-6 (10...60Hz).
Shock	11ms / 15g	IEC 68-2-27 (3 shocks).
Operation height	max. 2,000m	Above sea level.

Efficiency and Power Loss

DPD155.131, 133, 134	typ. 85% / 21W	@ 24V DCin, Iout = 100%.
DPD155.331	typ. 90% / 12W	@ 48V DCin, Iout = 100%.

Reliability

Only long life (> 2,000h @105° C) electrolytic capacitors are used.		
Function test	100%	Test certificate enclosed.
Run-in (burn-in)	24h	Full load, Ta = +60° C, on/off cycle.

DPD155 · 1 Output · DIN Rail DC/DC Converter · 120 Watt

Fuse

The converter has electronic protection against external short-circuits. In case of an internal defect, a fuse disconnects the unit. It can only be replaced by opening the unit which should be done by the supplier.

Installation for Operating

Install DIN rail TS35/7.5 horizontally, ensuring correct orientation.

For other installation considerations consult your representative. Ensure free air flow.

Dimensions and Connections

Fully enclosed Al/Mg alloy housing. All mechanical dimensions are in mm.

- 1) Do not remove PE screw.

Screw terminals:

On the front side. These accept wire of up to 4mm² cross section (single-core cable) or 2.5mm² cross section (multi-core flex).

Remove 9 to 15 mm of insulation from wire.

Take care of standards which must be satisfied, e.g. VDE 0100 or EN 60 950.

Caution:

Do not remove any screws on box, as internal safety connections could be disconnected!

Schematic

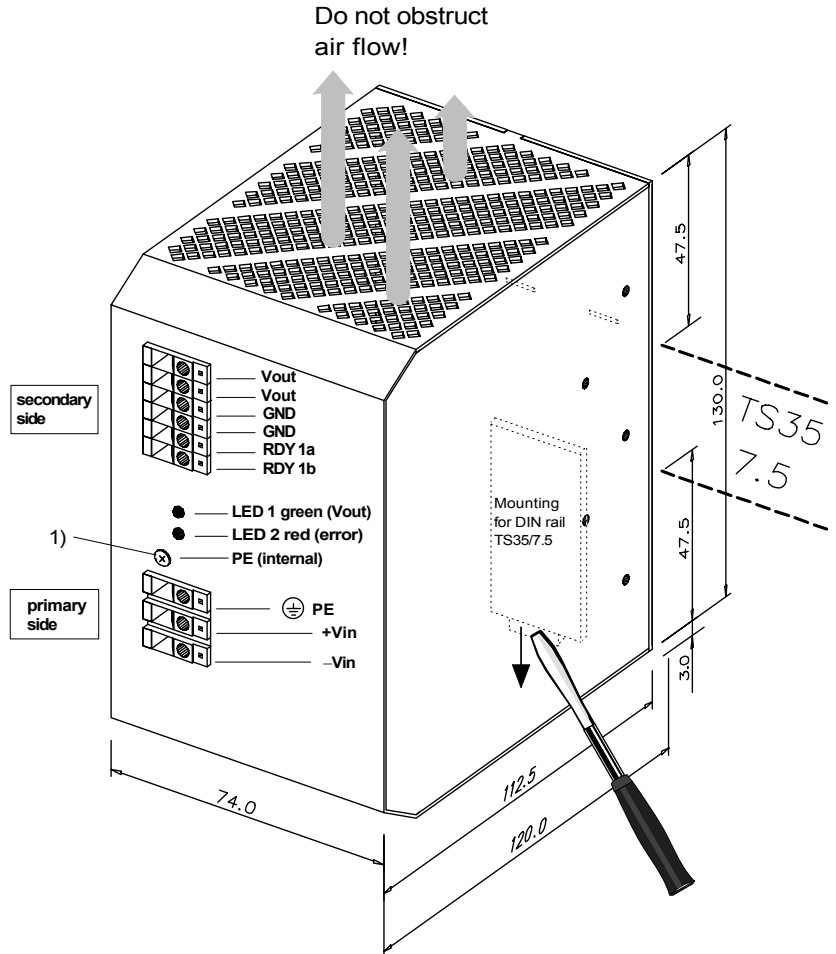
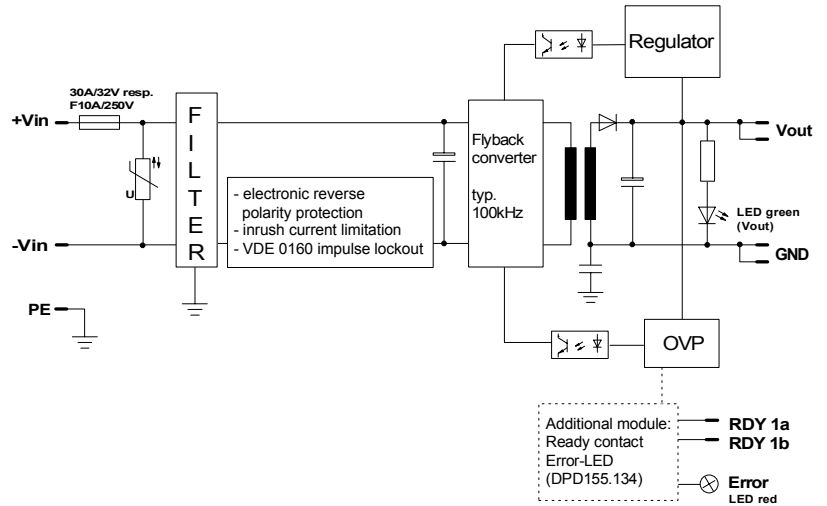

Modifications (contact supplier)

Other output voltages.

Other DC input voltages.

Lower cost versions.