



POWER SUPPLY

- ? 2AC 380-480V
- ? 2 Phase Input
- ? No Neutral Wire Required
- ? Input Fuse Included
- ? Efficiency up to 90.0%
- ? Full Output Power Between -10°C and +60°C
- ? Quick-connect Spring-clamp Terminals
- ? 3 Year Warranty

GENERAL DESCRIPTION

The ML100.200 is a simple and cost effective approach to convert the AC voltage of a typical three phase system into a regulated DC voltage. It only requires two phases and thereby saves terminal space, terminal cost, wires, fuses and installation time.

The ML100.200 is very compact, high efficient and easy to use. The input is internally protected, which makes external fuses unnecessary in many cases.

Weighing only 360g, it is a lightweight compared to the 50/60Hz control transformers, which are commonly used for low-power control voltages where a neutral wire is not available.

High immunity to transients and power surges as well as low electromagnetic emission makes usage in nearly every environment possible.

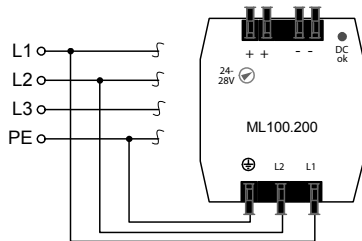

SHORT -FORM DATA

Output voltage	DC 24V	
Adjustment range	24-28V	guaranteed
Output current	4.2-3.6A	
Output power	100W	
Output ripple	< 50mVpp	20Hz to 20MHz
Input voltage	2AC 380-480V	±15%
Mains frequency	50-60Hz	±6%
AC Input current	typ. 0.46 / 0.4A	at 400 / 480Vac
Power factor	typ. 0.6 / 0.55	at 400 / 480Vac
AC Inrush current	typ. 36 / 45A	at 400 / 480Vac
Hold-up time	typ. 48 / 85ms	at 400 / 480Vac
DC Input	consult PULS	
Efficiency	89.5 / 89.0%	at 400 / 480Vac
Losses	11.7 / 12.3W	at 400 / 480Vac
Temperature range	-10°C to +70°C	operational
	-40°C to +85°C	storage, transport
Derating	2.5 W/°C	+60 to +70°C
Humidity	< 95% r.H.	IEC 60068-2-30
	Do not energize while condensation is present	
Vibration	2g (2 hours/axis)	IEC 60068-2-6
Shock	30g 6ms, 20g 11ms	IEC 60068-2-27
Dimensions	72.5x75x103mm	WxHxD

ORDER NUMBERS

Power Supply ML100.200 24-28V Power Supply
 Accessory MLY02.100 Decoupling Module

MARKINGS



OUTPUT

Output voltage	nom	DC 24V
Adjustment range	min	24V-28V
Factory set	typ	24.5V
Output current	nom	4.2A at 24V, 3.6A at 28V
Line regulation	max	20mV 323...552Vac
Load regulation	max	240mV static regulation
Serial use		allowed
Parallel use		allowed
Return voltage	max	35V
OVP	typ	34V
	max	39V

Output voltage vs. output current, typ.

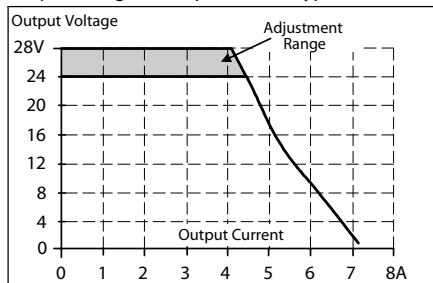

Output current vs. ambient temperature

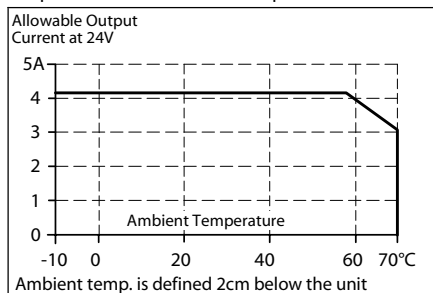

SAFETY AND PROTECTION

Input / output insulation	SELV	IEC/EN 60950-1
	PELV	EN 60204-1
		3000Vac 2s type test
Degree of pollution	2	EN 50178
Degree of protection	IP 20	EN/IEC 60529
Class of protection	I	PE required
Over-voltage category	III	EN 50178
Internal input fuse	T3A15	in L1, not accessible
Temperature protection		not included

The power supply shall only be installed and put into operation by qualified personnel. This power supply is designed for installation in an enclosure and is intended for the general use, such as in industrial control, office, communication, and instrumentation equipment. Do not use this device in aircraft, trains and nuclear equipment, where malfunctioning of the power supply may cause severe personal injury or threaten human life. The information presented in this document is believed to be accurate and reliable and may change without notice.

TERMINALS AND WIRING

Type	Bi-stable, quick-connect spring clamp terminals. Shipped in open position.
Solid wire	0.3-2.5mm ²
Stranded wire	0.3-2.5mm ²
AWG	AWG 26-12
Stripping length	6mm / 0.25inch
Ferrules	allowed, but not required

EMC

EMC Immunity	EN 61000-6-1, EN 61000-6-2
EMC Emission	EN61000-6-3, EN 61000-6-4 EN 55011, EN 55022, FCC-15
Harmonic input current	EN61000-3-2 (PFC)
Flicker	EN61000-3-3

APPROVALS

UL 508	Industrial Control Equipment
UL 60950-1	Information Technology Equipment

FULFILLED STANDARDS

EN 61558-2-17	Safety of Power Transformers
EN/IEC 60204-1	Safety of Electrical Equip. of Machines
EN/IEC 60950-1	Information Technology Equipment
EN/IEC 61131-2	Programmable Controllers
EN 50178	Electronic Equip. Power Installations

DIMENSIONS AND WEIGHT

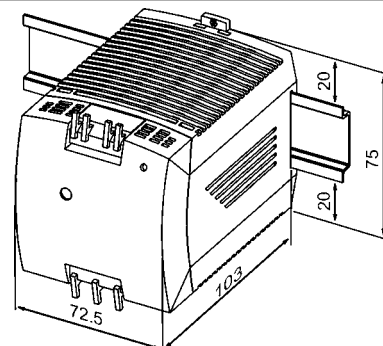

Use 35mm DIN-rails according to EN 60715 or EN 50022 with a height of 7.5 or 15mm. The DIN-rail height must be added to the depth (103mm) to calculate the total required installation depth.

Weight	max 360g	0.79lb
--------	----------	--------