



POWER SUPPLY

- ? AC 100-240V Wide-range Input
- ? NEC Class 1 Compliant
- ? Device Net[®] Approved
- ? Efficiency up to 92.7%
- ? Width only 60mm
- ? Active Power Factor Correction, PFC
- ? Short-term Operation from 60Vac to 300Vac
- ? Full Power Between -25°C and +60°C
- ? Negligibly low Inrush Current
- ? DC-OK Relay Contact
- ? Quick-connect Spring-clamp Terminals
- ? 3 Year Warranty

1. GENERAL DESCRIPTION

The QS10.DNET power supply is a derivative of the Dimension QS10 family, which is specially designed to meet the Device Net[®] requirement. The QS10.DNET exists beside the QS5.DNET, which is the right choice to supply networks that use NEC Class 2 cables.

The specialties of Device Net[®] power supplies are:

- The nominal and overload currents are sized for the ratings of the Device Net[®] cables.
- Large load capacitors can be charged in a very short period of time.
- After turn on, the output voltage increases according to the Device Net[®] timing specification.
- The upper level of the output level is limited to protect the network.

The most outstanding features are a high efficiency, compact size, wide-range input voltage, a very low inrush surge and a DC-ok contact. High immunity to transients and power surges and a low electromagnetic emission makes usage in nearly every environment possible.

Unique quick-connect spring-clamp terminals allow a safe and fast installation. A large international approval package makes this unit suitable for nearly every situation.

2. SHORT-FORM DATA

Output voltage	DC 24V	
Adjustment range	24-24.5V	
Output current	8A	
Output power	192W	
Output ripple	< 50mVpp	20Hz to 20MHz
Input voltage	AC 100-240V	±15%
Mains frequency	50-60Hz	±6%
AC Input current	1.77 / 1.0A	at 120 / 230Vac
Power factor	0.98 / 0.92	at 120 / 230Vac
AC Inrush current	typ. 4 / 7A peak	at 120 / 230Vac
DC Input voltage	DC 110-300V	-20%/+25%
DC Input current	1.9 / 0.7A	at 110 / 300Vdc
Efficiency	92.3 / 92.7%	at 120 / 230Vac
Losses	16.0 / 15.1W	at 120 / 230Vac
Temperature range	-25°C to +70°C	operational
Derating	5W/°C	+60 to +70°C
Hold-up time	typ. 33 / 34ms	at 120 / 230Vac
Dimensions	60x124x117mm	WxHxD

3. ORDER NUMBERS

Power Supply	QS10.DNET	Standard unit
Accessory	ZM1.WALL	Wall mount bracket
	ZM13.SIDE	Side mount bracket
	YR2.DIODE	Decoupling module
	UF20.241	Buffer unit

4. MARKINGS



INDEX

PAGE

1. General Description	1
2. Short-form Data	1
3. Order Numbers	1
4. Markings	1
5. AC-Input	3
6. Input Inrush Current	4
7. DC-Input	4
8. Output	5
9. Hold-up Time	6
10. DC-OK Relay Contact	7
11. Efficiency and Power Losses	8
12. Functional Diagram	9
13. Front Side and User Elements	9
14. Terminals and Wiring	10
15. Reliability	10
16. EMC	11
17. Environment	12
18. Protection Features	13
19. Safety	13
20. Dielectric Strength	13

INDEX

PAGE

21. Approvals	14
22. Fulfilled Standards	14
23. Used Substances	14
24. Physical Dimensions and Weight	15
25. Installation and Operation Instructions	15
26. Accessory	16
27. Application Notes	17
27.1. Peak Current Capability	17
27.2. Back-feeding Loads	17
27.3. Output Circuit Breakers	18
27.4. External Input Protection	19
27.5. Parallel Use to Increase Output Power ..	19
27.6. Parallel Use for Redundancy	19
27.7. Daisy Chaining of Outputs	20
27.8. Series Operation	20
27.9. Inductive and Capacitive Loads	20
27.10. Operation on Two Phases	21
27.11. Use in a Tightly Sealed Enclosure	21
27.12. Mounting Orientations	22

INTENDED USE

The power supply shall only be installed and put into operation by qualified personnel.

This power supply is designed for installation in an enclosure and is intended for the general use, such as in industrial control, office, communication, and instrumentation equipment. Do not use this device in aircraft, trains and nuclear equipment, where malfunctioning of the power supply may cause severe personal injury or threaten human life.

TERMINOLOGY AND ABBREVIATIONS

PE and \oplus symbol	PE is the abbreviation for Protective Earth and has the same meaning as the symbol \oplus .
Earth, Ground	This document uses the term "earth" which is the same as the U.S. term "ground".
T.b.d.	To be defined, value or description will follow later.
AC 230V	A figure displayed with the AC or DC before the value represents a nominal voltage with standard tolerances (usually $\pm 20\%$) included. E.g.: DC 12V describes a 12V battery disregarding whether it is full (13.7V) or flat (10V) As long as not otherwise stated, AC 100V and AC 230V parameters are valid at 50Hz and AC 120V parameters are valid at 60Hz mains frequency.
230Vac	A figure with the unit (Vac) at the end is a momentary figure without any additional tolerances included.

DISCLAIMER

The information presented in this document is believed to be accurate and reliable and may change without notice.

5. AC-I NPUT

AC input	nom.	AC 100-240V	wide-range input, TN-, TT-, IT-Mains, see	Fig. 5-1
AC input range	min.	85-276Vac	continuous operation	
	min.	60-85Vac	full power for 200ms, no damage between 0 and 85Vac	
	min.	276-300Vac	< 500ms	
Input frequency	nom.	50 – 60Hz	±6%	
Turn-on voltage	typ.	81Vac	steady-state value, see	Fig. 5-1
Shut-down voltage	typ.	63Vac	steady-state value, see	Fig. 5-1
	typ.	55Vac	dynamical value	

		AC 100V	AC 120V	AC 230V	
Input current	typ.	2.13A	1.77A	1.0A	at 24V, 8A, see Fig. 5-3
Power factor *)	typ.	0.99	0.98	0.92	at 24V, 8A, see Fig. 5-4
Crest factor **)	typ.	1.65	1.67	1.85	at 24V, 8A
Start-up delay	typ.	800ms	650ms	340ms	see Fig. 5-2
Rise time	typ.	8ms	8ms	8ms	0mF, 24V, 8A, see Fig. 5-2
	typ.	15ms	15ms	15ms	10mF, 24V, 8A, see Fig. 5-2
Turn-on overshoot	max.	20mV	20mV	20mV	see Fig. 5-2

*) The power factor is the ratio of the true (or real

**) The crest factor is the mathematical ratio of the

) power to the apparent power in an AC circuit.

peak value to RMS value of the input current waveform.

Fig. 5-1 Input voltage range

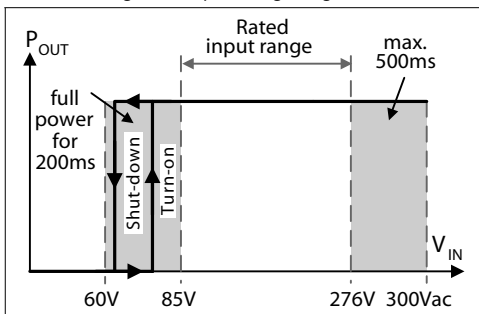

Fig. 5-2 Turn-on behavior, definitions

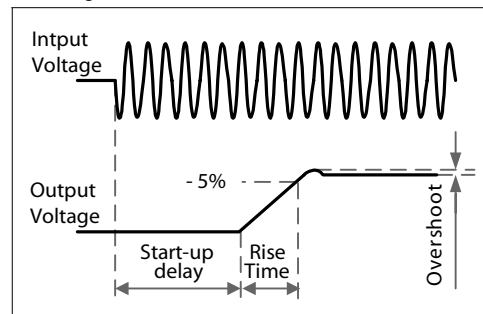

Fig. 5-3 Input current vs. output load at 24V

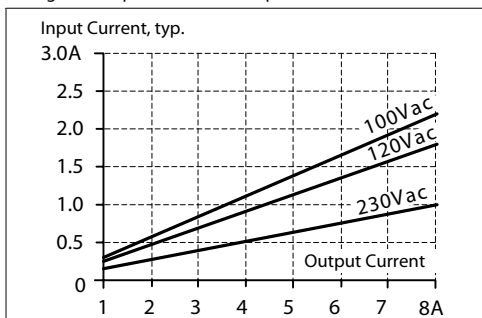
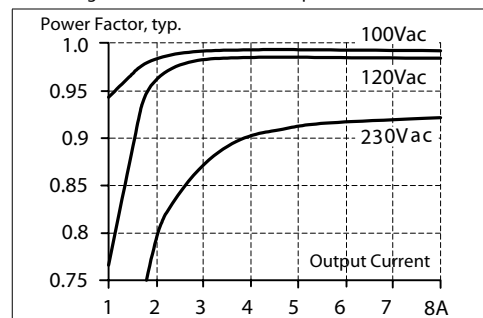

Fig. 5-4 Power factor vs. output load



6. INPUT INRUSH CURRENT

An active inrush limitation circuitry limits the input inrush current after turn-on of the input voltage and after short input voltage interruptions.

The charging current into EMI suppression capacitors is disregarded in the first milliseconds after switch-on.

		AC 100V	AC 120V	AC 230V	
Inrush current	max.	10A _{peak}	10A _{peak}	10A _{peak}	-25°C to +70°C
	typ.	5A _{peak}	4A _{peak}	7A _{peak}	-25°C to +70°C
Inrush energy	max.	1A ² s	1A ² s	1A ² s	-25°C to +70°C
Inrush delay	typ.	650ms	520ms	250ms	

Fig. 6-1 Input inrush current, typical behavior

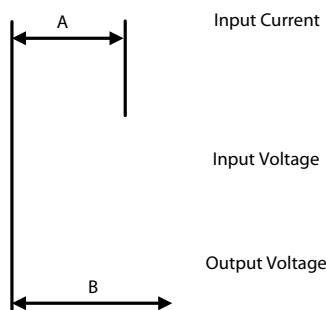

A: Inrush delay
B: Start-up delay

Input: 230Vac
Output: 24V, 8A
Ambient: 25°C
Upper curve: Input current 2A / DIV
Medium curve: Input voltage 500V / DIV
Lower curve: Output voltage 20V / DIV
Time basis: 100ms / DIV

7. DC-INPUT

DC input	nom.	DC 110-300V	
DC input range	min.	88-375Vdc	continuous operation
DC input current	typ.	1.9A / 0.7A	110Vdc / 300Vdc, at 12V, 15A output load
Turn-on voltage	typ.	80Vdc	steady state value
Shut-down voltage	typ.	55Vdc	steady state value

Fig. 7-1 Wiring for DC Input

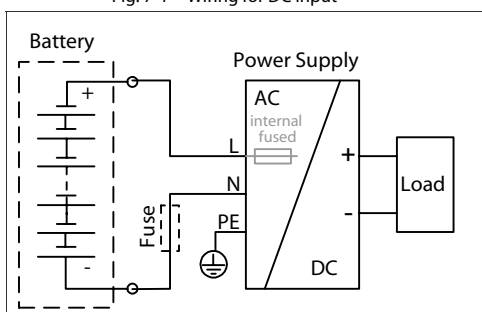

Instructions for DC use:

- Use a battery or similar DC source.
- Connect +pole to L and -pole to N.
- Connect the PE terminal to a earth wire or to the machine ground.

In case the -pole of the battery is not connected to earth, use an appropriate fuse to protect the N terminal.

8. OUTPUT

Output voltage	nom.	24V	
Adjustment range	min.	24-24.5V	guaranteed, multi turn potentiometer
	max.	25V	at clockwise end position of potentiometer
Factory setting		24.1V	±0.2%, at full load, cold unit
Line regulation	max.	10mV	60 to 300Vac
Load regulation	max.	100mV	static value, 0A → 8A → 0A
Ripple and noise voltage	max.	50mVpp	20Hz to 20MHz, 50Ohm
Output capacitance	typ.	7 000µF	
Output current	nom.	8A	at 24V, see Fig. 8-1
		12A	for typ. 200ms to charge network capacitors (= BonusPower [®])
Output power	nom.	192W	24V, continuous
Short-circuit current	min.	7A	load impedance 100mOhm, see Fig. 8-1
	max.	13A	load impedance 100mOhm, see Fig. 8-1

Peak current capability (up to several ms)

The power supply can deliver a peak current which is higher than the specified short term current. This helps to start current demanding loads or to safely operate subsequent circuit breakers.

The extra current is supplied by the output capacitors inside the power supply. During this event, the capacitors will be discharged and causes a voltage dip on the output. Detailed curves can be found in chapter 27.1.

Peak current voltage dips	typ.	from 24V to 20V	at 16A for 20ms
	typ.	from 24V to 20V	at 32A for 2ms
	typ.	from 24V to 16.5V	at 32A for 5ms

Fig. 8-1 Output voltage vs. output current, typ.

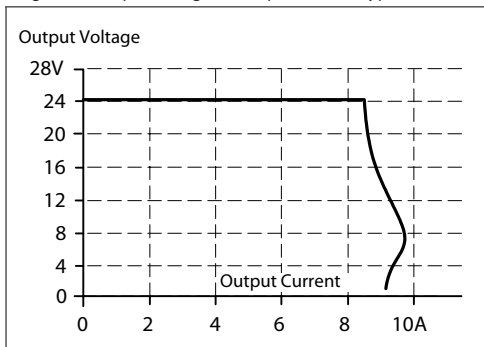

The Bonus Power[®] is available as soon as power comes on and immediately after the end of an output short circuit.

Fig. 8-2 BonusPower[®] after input turn-on

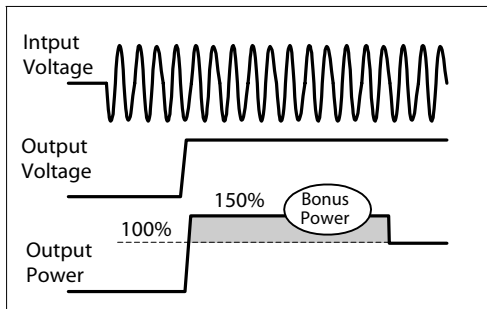
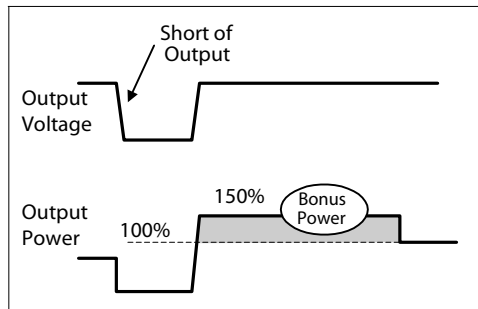

Fig. 8-3 BonusPower[®] after output short



9. HOLD-UP TIME

		AC 100V	AC 120V	AC 230V		
Hold-up Time	typ.	31ms	32ms	32ms	8A, 24V, see	Fig. 9-1
	typ.	72ms	72ms	73ms	4A, 24V, see	Fig. 9-1

Fig. 9-1 Hold-up time vs. input voltage

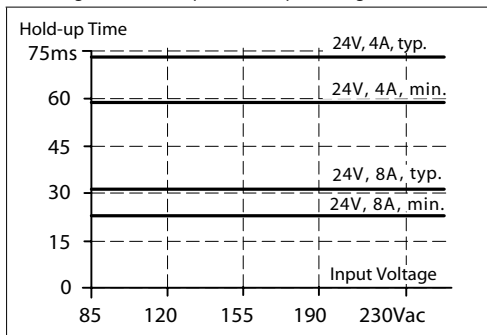
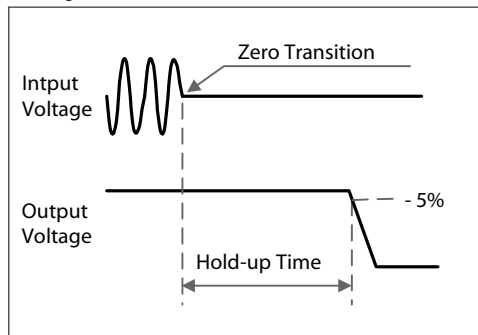

Fig. 9-2 Shut-down behavior, definitions



Note: At no load, the hold-up time can be up to one minute. The green DC-ok lamp is on during this time.

10. DC-OK RELAY CONTACT

This feature monitors the output voltage, which is produced by the power supply itself. It is independent of a back-fed voltage from a unit which is connected in parallel to the power supply output.

Contact closes	As soon as the output voltage reaches the adjusted output voltage.
Contact opens	As soon as the output voltage dips more than 10% below the adjusted output voltage. Short dips will be extended to a signal length of 250ms. Dips shorter than 1ms will be ignored.
Contact re-closes	As soon as the output voltage exceeds 90% of the adjusted voltage.
Contact ratings	max 60Vdc 0.3A, 30Vdc 1A, 30Vac 0.5A resistive load min 1mA at 5Vdc min. permissible load
Isolation voltage	See dielectric strength table in section 20

Fig. 10-1 DC-ok relay contact behavior

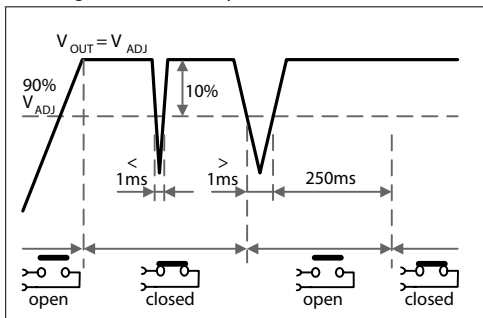

Note:

The DC-ok feature requires that the output voltage reaches the nominal (=adjusted) level after turn-on in order to function according to specification. If this level cannot be achieved, the overload lamp will be on and the DC-ok contact will be open. The overload signal will only shut off as soon as the adjusted voltage is reached. This is an important condition to consider particularly, if the load is a battery, the power supply is used in parallel or the power supply is used for N+1 redundant systems.

11. EFFICIENCY AND POWER LOSSES

		AC 100V	AC 120V	AC 230V	
Efficiency	typ.	91.5%	92.3%	92.7%	8A, 24V,
Power losses	typ.	17.8W	16.0W	15.1W	8A, 24V,
	typ.	5.6W	5.7W	5.9W	0A

Fig. 11-1 Efficiency vs. output current at 24V

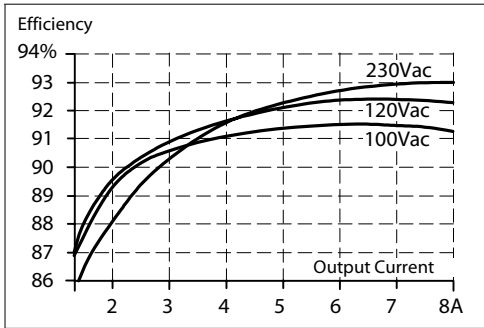

Fig. 11-2 Losses vs. output current at 24V



Fig. 11-3 Efficiency vs. input voltage, 24V, 8A

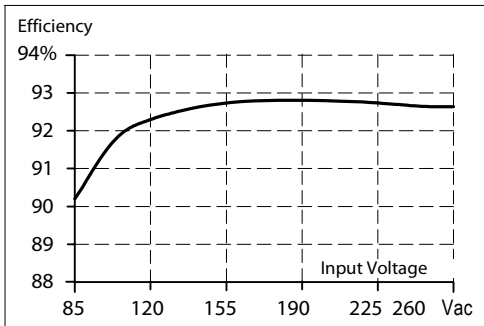
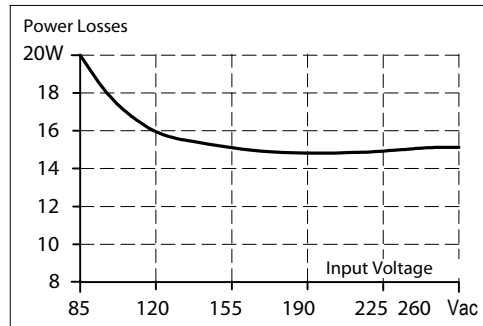
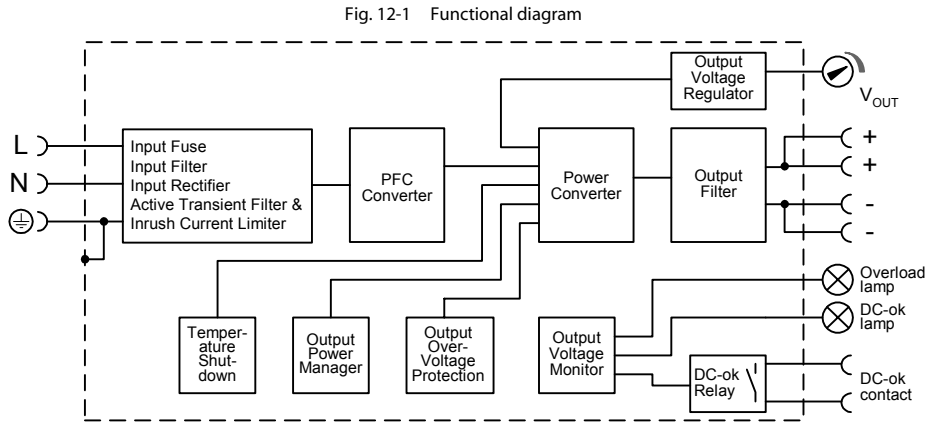

Fig. 11-4 Losses vs. input voltage, 24V, 8A



12. FUNCTIONAL DIAGRAM



13. FRONT SIDE AND USER ELEMENTS

Fig. 13-1 Front side

Output Terminals
Quick-connect spring-clamp terminals, no tools required

- + Positive output
- Negative (return) output
Dual pins per pole
- DC ok Relay contact (NO-contact)

Input Terminals
Quick-connect spring-clamp terminals, no tools required

- N ... Neutral input
- L ... Line (hot) input
- ⊕ ... PE (Protective Earth) input

See chapter 14 "Terminals and Wiring" to choose appropriate wire gauges

Output voltage potentiometer (multi turn potentiometer)
Open the flap to tune the output voltage.
Factory setting: 24.1V

- DC-ok lamp (green)
- Overload lamp (red)

	Overload lamp	DC-ok lamp	DC-ok contact
Normal mode	OFF	ON	Closed
BonusPower [®] mode	OFF	ON	Closed
Overload ($V_{OUT} < 90\%$)	ON	OFF	Open
Short-circuit ($V_{OUT} = ca. 0V$)	ON	OFF	Open
Over-temperature	Intermitted	OFF	Open
No input power	OFF	OFF	Open

DC-ok lamp and DC-ok contact function synchronized

14. TERMINALS AND WIRING

Type	Bi-stable, quick-connect spring clamp terminals. IP20 Finger safe construction. Suitable for field- and factory installation. Shipped in open position.
Solid wire	0.5-6mm ²
Stranded wire	0.5-4mm ²
American wire gauge	20-10 AWG
Ferrules	allowed, but not required
Wire stripping length	10mm / 0.4inch
Pull-out force	10AWG:80N, 12AWG:60N, 14AWG:50N, 16AWG:40N (according to UL486E)

Fig. 14-1 Connecting a wire

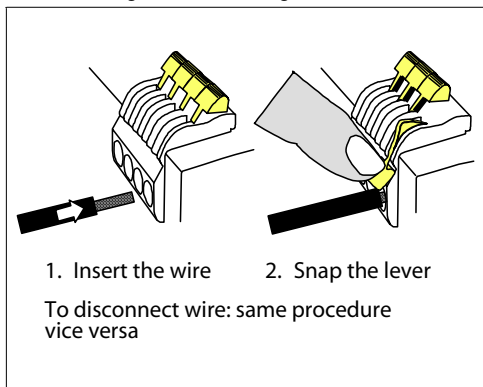

Instructions:

- Use appropriate copper cables that are designed for an operating temperature of: 60°C for ambient up to 45°C and 75°C for ambient up to 60°C minimum.
- Follow national installation codes and installation regulations!
- Ensure that all strands of a stranded wire enter the terminal connection!
- Up to two stranded wires with the same cross section are permitted in one connection point (except PE wire).
- Do not use the unit without PE connection.

15. RELIABILITY

		AC 100V	AC 120V	AC 230V	
Lifetime expectancy	min.	46 000h	57 000h	65 000h	40°C, 24V, 8A
	min.	107 000h	115 000h	112 000h	40°C, 24V, 4A
	min.	130 000h	15 years	15 years	25°C, 24V, 8A
MTBF SN 29500, IEC 61709		511 000h	572 000h	621 000h	40°C, 24V, 8A
		884 000h	898 000h	1 074 000h	25°C, 24V, 8A
MTBF MIL HDBK 217F		357 000h	364 000h	369 000h	40°C, 24V, 8A, Ground Benign GB40
		489 000h	499 300h	505 000h	25°C, 24V, 8A, Ground Benign GB25

The Lifetime expectancy shown in the table indicates the operating hours (service life) and is determined by the lifetime expectancy of the built-in electrolytic capacitors.

Lifetime expectancy is specified in operational hours. Lifetime expectancy is calculated according to the capacitor's manufacturer specification. The prediction model allows a calculation of up to 15 years from date of shipment.

MTBF stands for Mean Time Between Failure, which is calculated according to statistical device failures, and indicates reliability of a device. It is the statistical representation of the likelihood of the unit to fail and does not necessarily represent the life of a product.

16. EMC

The power supply is suitable for applications in industrial environment as well as in residential, commercial and light industry environment without any restrictions. CE mark is in conformance with EMC guideline 89/336/EEC and 93/68/EEC and the low-voltage directive (LVD) 73/23/EWG. A detailed EMC Report is available upon request

EMC Immunity	EN 61000-6-1 EN 61000-6-2	Generic standards
Electrostatic discharge	EN 61000-4-2	Contact discharge 8kV Criterion A Air discharge 15kV Criterion A
Electromagnetic RF field	EN 61000-4-3	80MHz-1GHz 10V/m Criterion A
Fast transients (Burst)	EN 61000-4-4	Input lines 4kV Criterion A Output lines 2kV Criterion A
Surge voltage on input	EN 61000-4-5	L → N 2kV Criterion A N / L → PE 4kV Criterion A
Surge voltage on output	EN 61000-4-5	+ → - 500V Criterion A + / - → PE 500V Criterion A
Conducted disturbance	EN 61000-4-6	0.15-80MHz 10V Criterion A
Mains voltage dips	EN 61000-4-11	70% of 100Vac 70Vac, 10ms Criterion A 40% of 100Vac 40Vac, 100ms Criterion C 40% of 100Vac 40Vac, 1000ms Criterion C
Voltage interruptions	EN 61000-4-11	0Vac, 5000ms Criterion C
Voltage sags	SEMI F47 0200	96Vac, 1000ms Criterion A 84Vac, 500ms Criterion A 60Vac, 200ms Criterion A
Input voltage swells	PULS internal standard	300Vac, 500ms Criterion A
Powerful transients	VDE 0160	over entire load range 750V, 1.3ms Criterion A

Criteria:

A: Power supply shows normal operation behavior within the defined limits.

C: Temporary loss of function is possible. Power supply might shut down and restarts by itself. No damages or hazards for the power supply occur.

EMC Emission	EN 61000-6-3 and EN 61000-6-4	Generic standards
Conducted emission	EN 55011, EN 55022, FCC Part 15, CISPR 11, CISPR 22 EN 55022	Class B, input lines Class B, output lines
Radiated emission	EN 55011, EN 55022	Class B
Harmonic input current	EN 61000-3-2	Fulfilled, active PFC
Voltage fluctuations, flicker	EN 61000-3-3	Fulfilled

This device complies with FCC Part 15 rules.

Operation is subjected to following two conditions: (1) this device may not cause harmful interference, and (2) this device must accept any interference received, including interference that may cause undesired operation.

Switching Frequencies	The power supply has three converters with three different switching frequencies included. Two are nearly constant. The other one is input voltage and load dependent.
Switching frequency 1	35kHz nearly constant
Switching frequency 2	105kHz nearly constant
Switching frequency 3	40kHz to 220kHz input voltage and load dependent

17. ENVIRONMENT

Operational temperature	-25°C to +70°C (-13°F to 158°F)	reduce output power above +60°C	
Output de-rating	5W/°C	60-70°C (140°F to 158°F), see	Fig. 17-1
Storage temperature	-40 to +85°C (-40°F to 185°F)	storage and transportation	
Humidity	5 to 95% r.H.	IEC 60068-2-30	Do not energize while condensation is present
Vibration sinusoidal	2-17.8Hz: ±1.6mm; 17.8-500Hz: 2g 2 hours / axis	IEC 60068-2-6	
Vibration random	0.5m ² (s ³) 2 hours / axis	IEC 60068-2-64	
Shock	30g 6ms, 20g 11ms 3 bumps / direction, 18 bumps in total	IEC 60068-2-27	
Altitude	0 to 6000m (0 to 20 000ft)	Reduce output power or ambient temperature above 2000m sea level.	
Output de-rating (for altitude)	15W/1000m or 5°C/1000m	above 2000m (6500ft), see	Fig. 17-2
Over-voltage category	III II	EN 50178, altitudes up to 2000m Altitudes from 2000m to 6000m	
Degree of pollution	2	EN 50178, not conductive	

Fig. 17-1 Output current vs. ambient temp.,

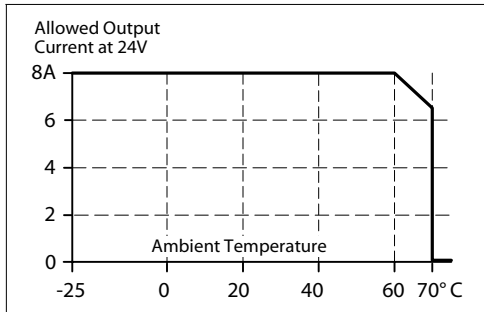
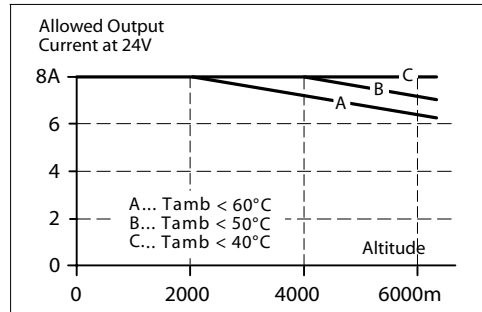

Fig. 17-2 Output current vs. altitude



The ambient temperature is defined as the air temperature 2cm below the unit.

18. PROTECTION FEATURES

Output protection	Electronically protected against overload, no-load and short-circuits	
Output over-voltage protection	typ. 27Vdc max. 29.5Vdc	In case of an internal power supply defect, a redundant circuitry limits the maximum output voltage. The output shuts-down and automatically attempts to restart.
Output over-current protection	Electronically limited	See Fig. 8-1
Degree of protection	IP 20	EN/IEC 60529
Penetration protection	> 3.5mm	e.g. screws, small parts
Over-temperature protection	yes	output shut-down with automatic restart
Input transient protection	MOV (Metal Oxide Varistor) and active transient filter	
Internal input fuse	T6.3A H.B.C.	not user replaceable

Note: In case of a protection event, audible noise may occur.

19. SAFETY

Input / output separation	SELV PELV double or reinforced insulation	IEC/EN 60950-1 EN 60204-1, EN 50178, IEC 60364-4-41
Class of protection	I	PE (Protective Earth) connection required
Isolation resistance	> 5MΩ	input to output, 500Vdc
PE resistance	< 0.1Ω	between housing and PE terminal
Touch current (leakage current)	typ. 0.19mA typ. 0.29mA typ. 0.53mA < 0.25mA < 0.38mA < 0.74mA	100Vac, 50Hz, TN mains 120Vac, 60Hz, TN mains 230Vac, 50Hz, TN mains 110Vac, 50Hz, TN mains 132Vac, 60Hz, TN mains 264Vac, 50Hz, TN mains

20. DIELECTRIC STRENGTH

Fig. 20-1 Dielectric strength

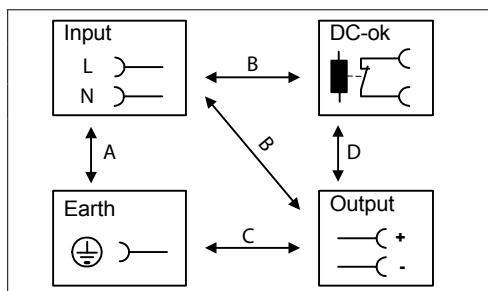

		A	B	C	D
Type test	60s	2500Vac	3000Vac	500Vac	500Vac
Factory test	5s	2500Vac	2500Vac	500Vac	500Vac
Field test	5s	2000Vac	2000Vac	500Vac	500Vac

Type tests and factory tests:
Conducted by the manufacturer. Do not repeat test in field!
Rules for field test:
Use appropriate test equipment which applies the voltage with a slow ramp! Connect L and N together as well as all output poles.

The output voltage is floating and has no ohmic connection to ground. To fulfill the PELV requirements according to EN60204-1 § 6.4.1, we recommend that either the + pole, the - pole or any other part of the output circuit shall be connected to the protective earth system. This helps to avoid situations in which a load starts unexpectedly or cannot be switched off any more when unnoticed earth faults occur.

21. APPROVALS

IEC 60950-1	IECEE CB SCHEME	CB Scheme, Information Technology Equipment
Device Net®		DeviceNet conformance tested by the open Device Net® vendor organization.
UL 508		LISTED E198865 listed for use in U.S.A. (UL 508) and Canada (C22.2 No. 14-95) Industrial Control Equipment
UL 60950-1		RECOGNIZED E137006 recognized for the use in U.S.A. (UL 60950-1) and Canada (C22.2 No. 60950) Information Technology Equipment, Level 3
UL 1604		RECOGNIZED E246877 recognized for use in U.S.A. (UL 1604) and Canada (C22.2 No. 213-M1987) Hazardous Location Class I Div 2 T4 Groups A,B,C,D and Class I Zone 2 Groups IIA, IIB and IIC
The unit is suitable for use in Class I Division 2 Groups A, B, C, D locations as well as for Class I Zone 2 Groups IIA, IIB and IIC locations. Substitution of components may impair suitability for Class I Division 2 environment. Do not disconnect equipment unless power has been switched off. Wiring must be in accordance with Class I, Division 2 wiring methods of the National Electrical Code, NFPA 70, and in accordance with other local or national codes.		
Marine		GL (Germanischer Lloyd) classified and ABS (American Bureau for Shipping) PDA for marine and offshore applications. Environmental category: C, EMC2
SEMI F47		SEMI F47-0200 Power Quality Star Ride-through compliance for semiconductor industry. Full SEMI range compliance (Input : 120Vac or 208Vac, output: 192W)

22. FULFILLED STANDARDS

EN 61558-2-17	Safety of Power Transformers
EN/IEC 60204-1	Safety of Electrical Equipment of Machines
EN/IEC 61131-2	Programmable Controllers
EN 50178	Electronic Equipment in Power Installations

23. USED SUBSTANCES

The unit does not release any silicone and is suitable for the use in paint shops.

Electrolytic capacitors included in this unit do not use electrolytes such as Quaternary Ammonium Salt Systems.

Plastic housings and other molded plastic materials are free of halogens, wires and cables are not PVC insulated.

The production material within our production does not include following toxic chemicals:
 Polychlorized Biphenyl (PCB), Polychlorized Terphenyl (PCT), Pentachlorophenol (PCP), Polychlorinated naphthalene (PCN), Polybrom Biphenyl (PBB), Polybrom Biphenyl-oxyd (PBO), Polybrominated Diphenylether (PBDE), Polychlorinated Diphenylether (PCDE), Polydibromphenyl Oxyd (PBDO), Cadmium, Asbest, Mercury, Silicia

24. PHYSICAL DIMENSIONS AND WEIGHT

Weight	900g / 1.98lb
DIN-Rail	Use 35mm DIN-rails according to EN 60715 or EN 50022 with a height of 7.5 or 15mm. The DIN-rail height must be added to the depth (117mm) to calculate the total required installation depth.
Electronic files with mechanical data can be downloaded	

Fig. 24-1 Front view

Fig. 24-2 Side view

25. INSTALLATION AND OPERATION INSTRUCTIONS

Mounting Orientation:

Output terminal must be located on top and input terminal on the bottom. For other orientations see section 27.12.

Cooling:

Convection cooled, no forced cooling required. Do not cover ventilation grid (e.g. cable conduits) by more than 30%!

Installation clearances:

40mm on top, 20mm on the bottom, 5mm on the left and right side are recommended when loaded permanently with full power. In case the adjacent device is a heat source, 15mm clearance is recommended.

Risk of electrical shock, fire, personal injury or death!

Do not use the unit without proper earth connection (Protective Earth). Use the pin on the terminal block for earth connection and not one of the screws on the housing.

Turn power off before working on the power supply. Protect against inadvertent re-powering.

Make sure the wiring is correct by following all local and national codes.

Do not open, modify or repair the unit.

Use caution to prevent any foreign objects from entering into the housing.

Do not use in wet locations or in areas where moisture or condensation can be expected.

Service parts:

The unit does not contain any serviceable parts. The tripping of an internal fuse is caused by an internal defect. If damage or malfunctioning should occur during operation, immediately turn power off and send unit to factory for inspection!

26. ACCESSORY

ZM1.WALL Wall mounting bracket

This bracket is used to mount Dimension units onto a flat surface without utilizing a DIN-Rail. The two aluminum brackets and the black plastic slider of the unit have to be detached, so that the two steel brackets can be mounted.

Fig. 26-1 ZM1.WALL Wall Mounting Bracket



Fig. 26-2 Assembled Wall Mounting Bracket

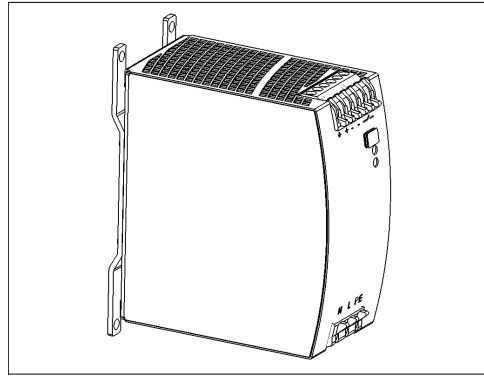

ZM13.SIDE Side mounting bracket

This bracket is used to mount Dimension units sideways with or without utilizing a DIN-Rail. The two aluminum brackets and the black plastic slider of the unit have to be detached, so that the steel brackets can be mounted. For sideways DIN-rail mounting, the removed aluminum brackets and the black plastic slider need to be mounted on the steel bracket.

Fig. 26-3 ZM13.SIDE Side Mounting Bracket

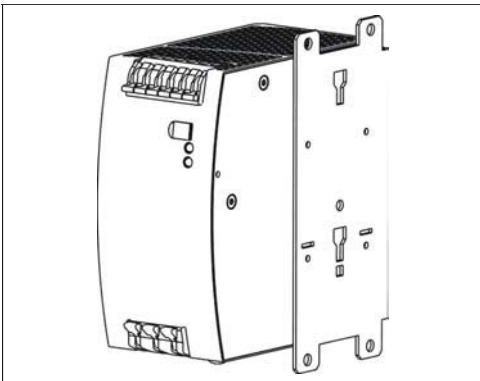
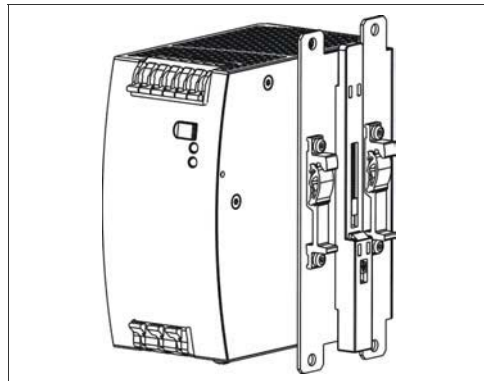

Fig. 26-4 Side Mounting with DIN-rail brackets



27. APPLICATION NOTES

27.1. PEAK CURRENT CAPABILITY

Solenoids, contactors and pneumatic modules often have a steady state coil and a pick-up coil. The inrush current demand of the pick-up coil is several times higher than the steady state current and usually exceeds the nominal output current. The same situation applies, when starting a capacitive load.

Branch circuits are often protected with circuit breakers or fuses. In case of a short or an overload in the branch circuit, the fuse needs a certain amount of over-current to trip or to blow. The peak current capability ensures the safe operation of subsequent circuit breakers.

Assuming the input voltage is turned on before such an event, the power supply can deliver extra current. Discharging this capacitor causes a voltage dip on the output. The following two examples show typical voltage dips:

ent, the built-in large sized output capacitors inside the power supply can deliver extra current. Discharging this capacitor causes a voltage dip on the output. The following

Fig. 27-1 Peak load 16A for 50ms, typ.

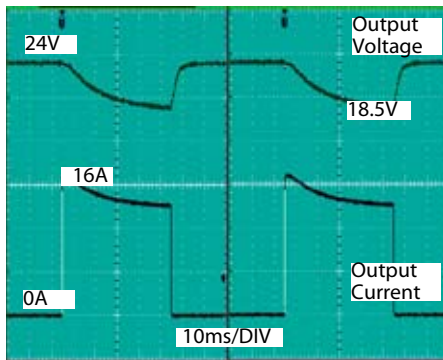

Peak load 16A (resistive) for 50ms
Output voltage dips from 24V to 18.5V.

Fig. 27-2 Peak load 32A for 5ms, typ.

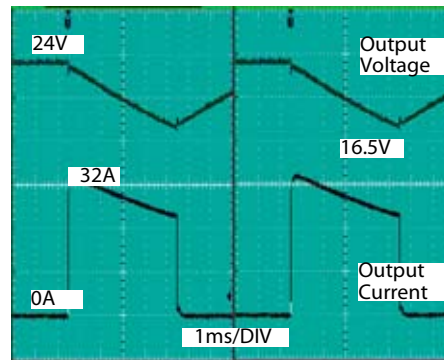

Peak load 32A (resistive) for 5ms
Output voltage dips from 24V to 16.5V.

Please note: The DC-OK relay triggers when the voltage dips more than 10% for longer than 1ms.

27.2. BACK-FEEDING LOADS

Loads such as decelerating motors and inductors can feed voltage back to the power supply. This feature is also called return voltage immunity or resistance against Back-E.M.F. (Electro Magnetic Force).

This power supply is resistant and does not show malfunctioning when a load feeds back voltage to the power supply. It does not matter, whether the power supply is on or off.

The maximum allowed feed back voltage is 35Vdc. The absorbing energy can be calculated according to the built-in large sized output capacitor which is specified in chapter 8.

27.3. OUTPUT CIRCUIT BREAKERS

Standard miniature circuit breakers (MCBs) can be used for branch protection. Ensure that the MCB is rated for DC voltage, too. The following tests show which circuit breakers the power supply typically trips.

Circuit breakers have huge tolerances in their tripping behavior. Therefore, these typical tests can only be used as a recommendation or for comparing two different power supplies. Furthermore, the loop impedance has a major influence on whether a breaker trips or not. Two tests were performed, representing typical situations:

Test 1: Short circuit with S1 on the power supply end of the cable (loop impedance approx. 20mOhm)

Fig. 27-3 Branch protectors, test circuit 1

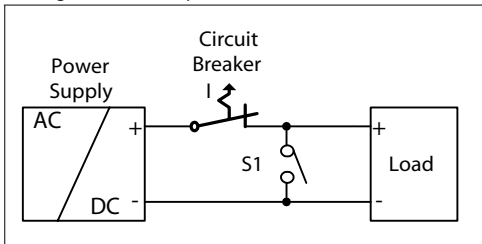

Parameters:

Input voltage: 230Vac, load current: 0A
Tripping time shorter than 5s.

The following circuit breaker tripped during the test:

- A - or Z - Characteristic: equal or smaller 25A
- B - Characteristic: equal or smaller 16A
- C - Characteristic: equal or smaller 10A

Test 2: Short circuit with S1 on the load end (additional impedance included; represents longer load wire length).

Fig. 27-4 Branch protectors, test circuit 2

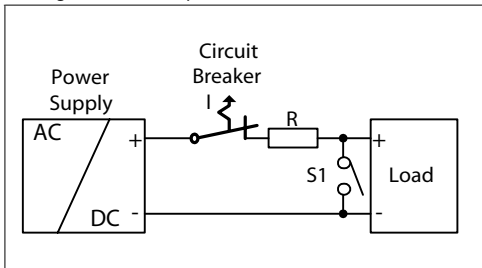

Parameters:

Input voltage: 230Vac, load current: 0A
Tripping time shorter than 5s.

The following circuit breaker tripped during the test:

- A - or Z - Characteristic: $\leq 16A$ and $R < 82m\Omega$
- B - Characteristic: $\leq 6A$ and $R < 180m\Omega$
- C - Characteristic: $\leq 4A$ and $R < 220m\Omega$

What does this resistance mean in wire length?

	0.5mm ²	0.7mm ²	1.0mm ²	1.5mm ²	2.5mm ²	4.0mm ²
82mOhm	2.3m	3.2m	4.6m	6.9m	11.4m	18.3m
180mOhm	5.0m	7.0m	10.0m	15.0m	25.1m	40.1m
220mOhm	6.1m	8.6m	12.3m	18.4m	30.6m	49.0m

Example:

Which wire gauge must be used to trip a B-Characteristic circuit breaker with a rating of 6A? The load wire length is 21m.

Answer: A 6A B-Characteristic circuit breaker requires a loop impedance of less than 180mOhm (test results). The wire length table shows that up to 25.1m wire with a cross section of 2.5mm² are below 180mOhm. A wire not smaller than 2.5mm² shall be used.

27.4. EXTERNAL INPUT PROTECTION

The unit is tested and approved for branch circuits up to 20A. External protection is only required, if the supplying branch has an ampacity greater than this. In some countries local regulations might apply. Check also local codes and local requirements.

If an external fuse is necessary or utilized, a minimum value is required to avoid undesired tripping of the fuse.

		B-Characteristic	C-Characteristic
Ampacity	max.	20A	20A
	min.	6A	4A

27.5. PARALLEL USE TO INCREASE OUTPUT POWER

Power supplies can be paralleled to increase the output power.

Fig. 27-5 Schematic for parallel operation

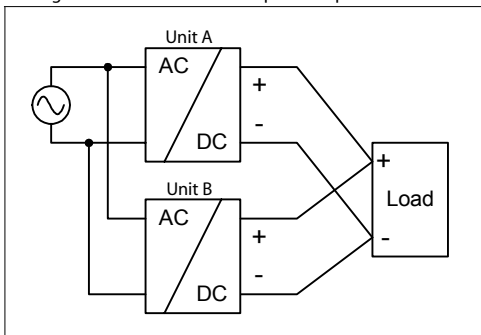

Instructions for parallel use:

- Use only power supplies from the same series (Q-Series).
- Adjust the output voltages of all power supplies to approximately the same value ($\pm 500\text{mV}$). Otherwise, the DC-ok signal might not work properly.
- A fuse (or diode) on the output is only required if more than three units are connected in parallel.
- Do not load terminals with more than 25A. Follow wiring instructions according to chapter 27.7
- Keep an installation clearance of 15mm (left/right) between two power supplies and avoid installing the power supplies on top of each other.

27.6. PARALLEL USE FOR REDUNDANCY

Power supplies can be paralleled for redundancy to gain a higher system availability. Redundant systems require a certain amount of extra power to support the load in case one power supply unit fails. The simplest way is to put two Q-Series power supplies in parallel. This is called a 1+1 redundancy. In case one power supply unit fails, the other one is automatically able to support the load current without any interruption. Redundant systems for a higher power demand are usually built in a N+1 method. E.g. Five power supplies, each rated for 10A are paralleled to build a 40A redundant system.

Please note: This simple way to build a redundant system does not cover failures such as an internal short circuit in the secondary side of the power supply. In such a - virtually nearly impossible - case, the defect unit becomes a load for the other power supplies and the output voltage can not be maintained any more. This can only be avoided by utilizing decoupling diodes which are included in the decoupling module YR2.DIODE.

Recommendations for building redundant power systems:

- Use separate input fuses for each power supply.
- Monitor the individual power supply units. A DC-ok lamp and a DC-ok contact is already included in the units. This feature reports a faulty unit.
- When possible, connect each power supply to different phases or circuits.
- It is desirable to set the output voltages of all power supplies to the same value to avoid a false DC-ok signal.

27.7. DAISY CHAINING OF OUTPUTS

Daisy chaining (jumping from one power supply output to the next) is allowed as long as the maximum current through one terminal pin does not exceed 25A. If the current is higher, use a separate distribution terminal block.

Fig. 27-6 Daisy chaining of outputs

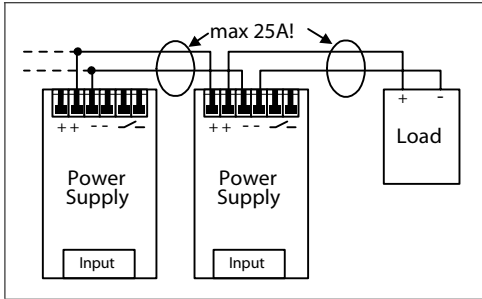
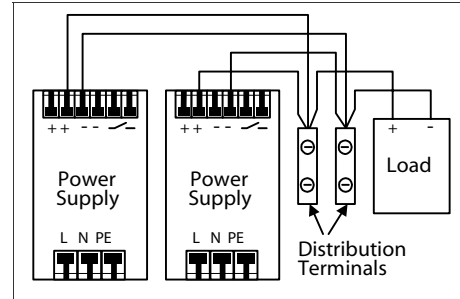

Fig. 27-7 Using distribution terminals



27.8. SERIES OPERATION

The power supply can be put in series to increase the output voltage.

Fig. 27-8 Schematic for series operation

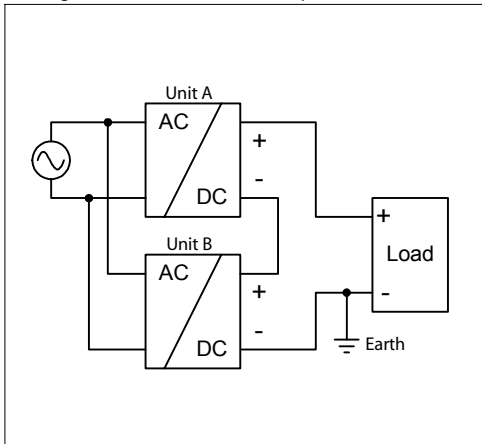

Instructions for use in series:

- It is possible to connect as many units in series as needed, providing the sum of the output voltage does not exceed 150Vdc.
- Voltages with a potential above 60Vdc are not SELV any more and can be dangerous. Such voltages must be installed with a protection against touching.
- For serial operation use power supplies of the same type.
- Earthing of the output is required when the sum of the output voltage is above 60Vdc.
- Keep an installation clearance of 15mm (left/right) between two power supplies and avoid installing the power supplies on top of each other.

Note: Avoid return voltage (e.g. from a decelerating motor or battery) which is applied to the output terminals.

27.9. INDUCTIVE AND CAPACITIVE LOADS

The unit is designed to supply any kind of load, including unlimited capacitive and inductive loads.

27.10.0 OPERATION ON TWO PHASES

Fig. 27-9 Schematic for two phase operation

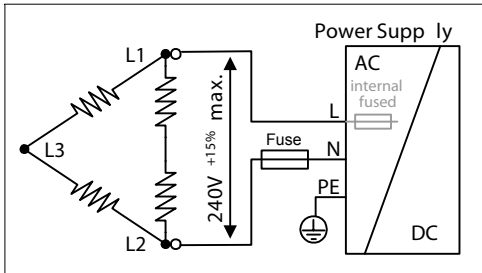

Instructions for two phase operation:

- A phase to phase connection is allowed as long as the supplying voltage is below 240V +15%.
- Use a fuse or a circuit breaker to protect the N input. The N input is internally not protected and is in this case connected to a hot wire.

Appropriate fuses or circuit breakers are specified in section 27.4 "External Input Protection".

27.11.U USE IN A TIGHTLY SEALED ENCLOSURE

When the power supply is installed in a tightly sealed enclosure, the temperature inside the enclosure will be higher than outside. The inside temperature defines the ambient temperature for the power supply.

Results from such an installation:

Power supply is placed in the middle of the box, no other heat producer inside the box

Enclosure:	Rittal Typ IP66 Box PK 9519 100, plastic, 180x180x165mm
Load:	24V, 6.4A; (=80%) load is placed outside the box
Input:	230Vac
Temperature inside enclosure:	45.1°C (in the middle of the right side of the power supply with a distance of 2cm)
Temperature outside enclosure:	27°C
Temperature rise:	18.1K

27.12.M MOUNTING ORIENTATIONS

Mounting orientations other than input terminals on the bottom and output on the top require a reduction in continuous output power or a limitation in the max. allowed ambient temperature. The amount of reduction influences the lifetime expectancy of the power supply. Therefore, two different derating curves for continuous operation can be found below:

Curve A1 Recommended output current.

Curve A2 Max allowed output current (results approx. in half the lifetime expectancy of A1).

Fig. 27-10
Mounting
Orientation A
Standard
Orientation

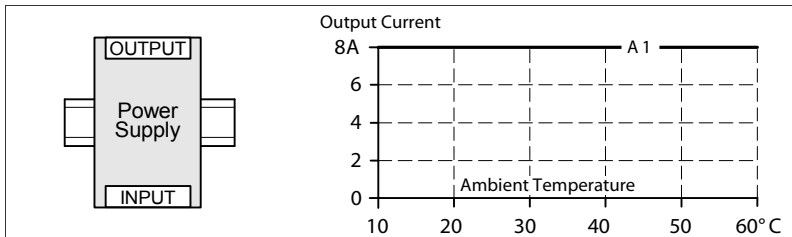

Fig. 27-11
Mounting
Orientation B
(Upside down)

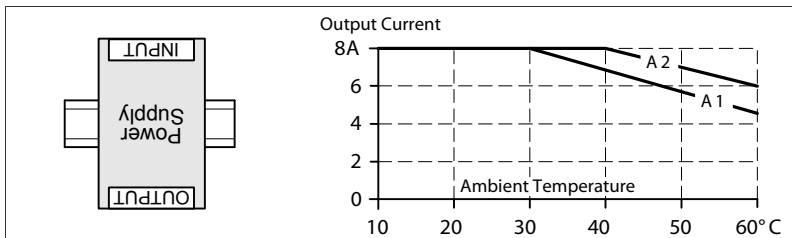

Fig. 27-12
Mounting
Orientation C
(Table-top
mounting)

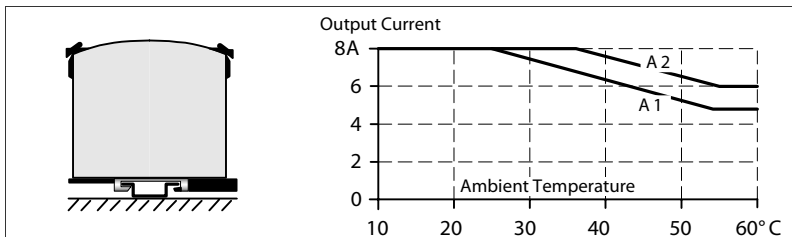

Fig. 27-13
Mounting
Orientation D
(Horizontal cw)

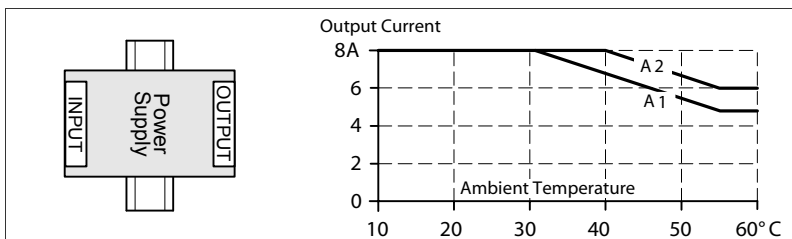

Fig. 27-14
Mounting
Orientation E
(Horizontal ccw)

