

POWER SUPPLY

- 3AC 380-480V Wide-range Input
- 2-Phase Operation also Possible
- Efficiency up to 95.4%
- Width only 65mm
- 150% Peak Load Capability
- Active Power Factor Correction PFC
- Active Input Transient Filter
- Full Power Between -25°C and +60°C
- Minimal Inrush Current
- DC-OK Relay Contact
- Quick-connect Spring Clamp Terminals
- 3 Year Warranty

1. GENERAL DESCRIPTION

The most outstanding features of this Dimension Q-Series DIN-rail power supply are the high efficiency and the small size, which are achieved by a synchronous rectification and further novel design details.

Large power reserves of 150% support the starting of heavy loads such as DC motors or capacitive loads. In many cases this allows the use of a unit from a lower wattage class which saves space and money.

High immunity to transients and power surges as well as low electromagnetic emission makes usage in nearly every environment possible.

The integrated output power manager and virtually no input inrush current make installation and usage simple with no jumpers and switches necessary. Diagnostics are easy due to the dry DC-ok contact, a green DC-ok LED and red overload LED.

Unique quick-connect spring-clamp terminals allow a safe and fast installation and a large international approval package for a variety of applications makes this unit suitable for nearly every situation.

2. SHORT-FORM DATA

Output voltage	DC 48V	
Adjustment range	48-55V	
Output current	10A	Continuous, 48V
	15A	For typ. 4s, 48V
Output power	480W	Continuous, 48V
	720W	For typ. 4s, 48V
Output ripple	< 100mVpp	20Hz to 20MHz
Input voltage	AC 380-480V	±15%
Mains frequency	50-60Hz	±6%
AC Input current	0.79 / 0.65A	At 3x400 / 480Vac
Power factor	0.94 / 0.95	At 3x400 / 480Vac
AC Inrush current	typ. 3A peak	
Efficiency	95.4 / 95.0%	At 3x400 / 480Vac
Losses	23.1 / 25.3W	At 3x400 / 480Vac
Temperature range	-25°C to +70°C	Operational
Derating	12W/°C	+60 to +70°C
Hold-up time	typ. 22 / 22ms	At 3x400 / 480Vac
Dimensions	65x124x127mm	WxHxD

3. ORDER NUMBERS

Power Supply	QT20.481	48-55V Standard unit
Accessory	ZM1.WALL	Wall mount bracket
	ZM14.SIDE	Side mount bracket
	YR2.DIODE	Decoupling module
	UF20.481	Buffer unit

4. MARKINGS



INDEX PAGE

1. General Description	1
2. Short-form Data	1
3. Order Numbers.....	1
4. Markings.....	1
5. AC-Input.....	3
6. DC-Input.....	4
7. Input Inrush Current	4
8. Output	5
9. Hold-up Time.....	7
10. DC-OK Relay Contact	7
11. Efficiency and Power Losses.....	8
12. Functional Diagram.....	9
13. Front Side and User Elements.....	9
14. Terminals and Wiring.....	10
15. Reliability	10
16. EMC.....	11
17. Environment.....	12
18. Protection Features	13
19. Safety	13
20. Dielectric Strength	13
21. Approvals.....	14

INDEX PAGE



22. Fulfilled Standards.....	14
23. Used Substances	14
24. Physical Dimensions and Weight.....	15
25. Installation and Operation Instructions	15
26. Accessory.....	16
27. Application Notes.....	17
27.1. Repetitive Pulse Loading.....	17
27.2. Peak Current Capability	18
27.3. Back-feeding Loads.....	18
27.4. Charging of Batteries.....	18
27.5. Output Circuit Breakers	19
27.6. External Input Protection.....	20
27.7. 2-Phase Operation.....	20
27.8. Parallel Use to Increase Output Power ..	21
27.9. Parallel Use for Redundancy.....	21
27.10. Daisy Chaining of Outputs.....	21
27.11. Series Operation.....	22
27.12. Inductive and Capacitive Loads	22
27.13. Use in a Tightly Sealed Enclosure	22
27.14. Mounting Orientations.....	23

INTENDED USE

The power supply shall only be installed and put into operation by qualified personnel.

This power supply is designed for installation in an enclosure and is intended for the general use, such as in industrial control, office, communication, and instrumentation equipment. Do not use this device in aircraft, trains and nuclear equipment, where malfunctioning of the power supply may cause severe personal injury or threaten human life.

TERMINOLOGY AND ABBREVIATIONS

PE and  symbol	PE is the abbreviation for Protective Earth and has the same meaning as the symbol  .
Earth, Ground	This document uses the term "earth" which is the same as the U.S. term "ground".
T.b.d.	To be defined, value or description will follow later.
AC 400V	A figure displayed with the AC or DC before the value represents a nominal voltage with standard tolerances (usually ±15%) included. E.g.: DC 12V describes a 12V battery disregarding whether it is full (13.7V) or flat (10V) As long as not otherwise stated, AC 380V and AC 400V parameters are valid at 50Hz and AC 480V parameters are valid at 60Hz mains frequency.
400Vac	A figure with the unit (Vac) at the end is a momentary figure without any additional tolerances included.

DISCLAIMER

The information presented in this document is believed to be accurate and reliable and may change without notice.

5. AC-I INPUT

AC input	nom.	3AC 380-480V	Wide-range input, TN-, TT-, IT-Mains, see Fig. 5-1 Consult factory if one phase is earthed.	
AC input range	min.	3x 323-552Vac	Continuous operation	
	min.	3x 280-323Vac	Full power for 200ms, no damage between 0 and 280Vac For 2-phase operation see section 27.7	
Input frequency	nom.	50-60Hz	±6%	
Turn-on voltage	typ.	3x 263Vac	Steady-state value, see Fig. 5-1	
Shut-down voltage	typ.	3x 242Vac	Steady-state value, see Fig. 5-1	
		3AC 400V	3AC 480V	
Input current	typ.	0.79A	0.65A	At 48V, 10A, all three phases equal voltage See Fig. 5-3
Power factor *)	typ.	0.94	0.95	At 48V, 10A, see Fig. 5-4
Start-up delay	typ.	350ms	290ms	See Fig. 5-2
Rise time	typ.	30ms	30ms	0mF, 48V, 10A, see Fig. 5-2
	typ.	40ms	40ms	10mF, 48V, 10A, see Fig. 5-2
Turn-on overshoot	max.	500mV	500mV	See Fig. 5-2

*) The power factor is the ratio of the true (or real) power to the apparent power in an AC circuit.

Fig. 5-1 Input voltage range

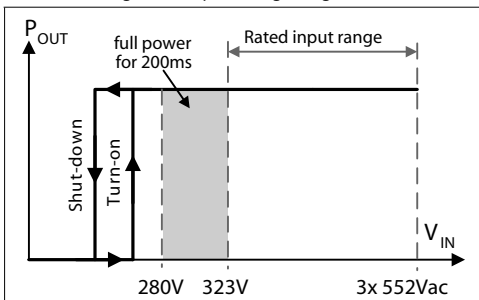

Fig. 5-2 Turn-on behavior, definitions

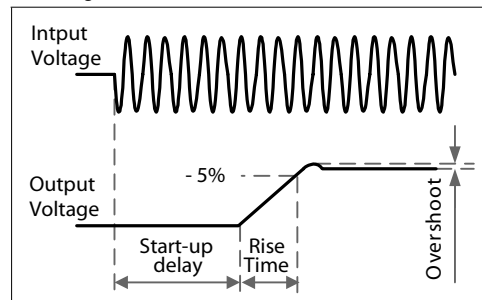

Fig. 5-3 Input current vs. output load at 48V

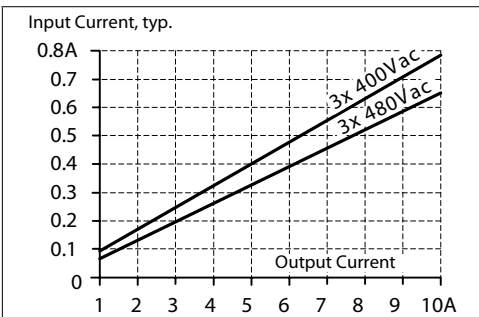
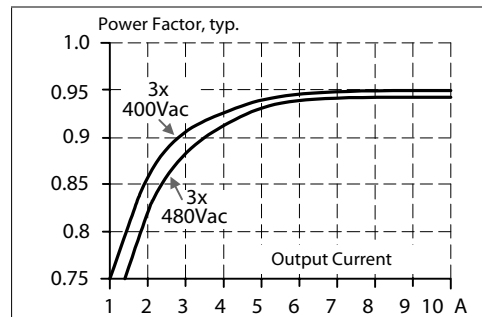

Fig. 5-4 Power factor vs. output load



6. DC-I NPUT

The QT20 series shall not be used with a DC-input voltage without consulting PULS.
 Check QTD20.241 for DC-input voltage. (special version for intermediate bus systems, drive systems)

7. INPUT INRUSH CURRENT

An active inrush limitation circuitry limits the input inrush current after turn-on of the input voltage and after short input voltage interruptions.

The charging current into EMI suppression capacitors is disregarded in the first milliseconds after switch-on.

		3AC 400V	3AC 480V	
Inrush current	max.	10A _{peak}	10A _{peak}	-25°C to +70°C
	typ.	3A _{peak}	3A _{peak}	-25°C to +70°C
Inrush energy	max.	1A ² s	1A ² s	-25°C to +70°C
Inrush delay	typ.	270ms	220ms	

Fig. 7-1 Input inrush current, typical behavior

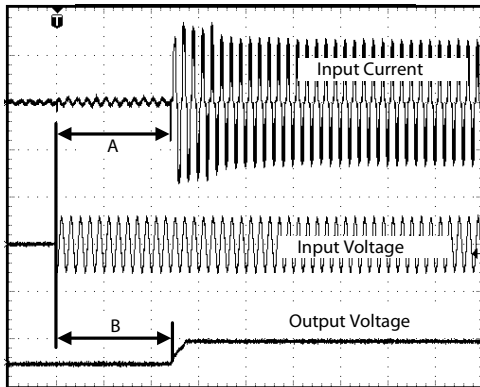

A: Inrush delay
 B: Start-up delay
 Input: 3x400Vac
 Output: 48V, 10A
 Ambient: 25°C
 Upper curve: Input current 2A / DIV
 Medium curve: Input voltage 1000V / DIV
 Lower curve: Output voltage 100V / DIV
 Time basis: 100ms / DIV

8. O UTPUT

Output voltage	nom.	48V	
Adjustment range	min.	48-55V	Guaranteed, multi turn potentiometer
	max.	56.1V	At clockwise end position of potentiometer
Factory setting		48.0V	±0.2%, at full load, cold unit
Line regulation	max.	10mV	320 to 552Vac
Load regulation	max.	100mV	Static value, 0A → 10A → 0A
Ripple and noise voltage	max.	100mVpp	20Hz to 20MHz, 50Ohm
Output capacitance	typ.	250µF	The energy of the bulk capacitor on the input side will be transferred to the output to supply short load peaks.

Continuous power capability

Output current	nom.	10A	At 48V, see Fig. 8-1
	nom.	8.7A	At 55V, see Fig. 8-1
Output power	nom.	480W	48V, continuous
	nom.	480W	55V, continuous
Short-circuit current	min.	10A	Load impedance 50mOhm, see Fig. 8-1
	max.	11.5A	Load impedance 50mOhm, see Fig. 8-1

BonusPower[®], short term power capability (up to typ. 4s)

The power supply is designed to support loads with a higher short-term power requirement without damage or shutdown. The short-term duration is hardware controlled by an output power manager. The BonusPower[®] is repeatedly available. Detailed information can be found in chapter 27.1.

Once BonusPower[®] has been stopped by the output power limiter, a timer disables the next BonusPower[®] capability. The recovery timer will start as soon as the output voltage reaches the adjusted value again, which usually happens after the load has been reduced.

Output current	nom.	15A	At 48V, see Fig. 8-1
	nom.	13A	At 55V, see Fig. 8-1
Output power	nom.	720W	48V, short term
	nom.	720W	55V, short term
Short-circuit current	min.	15A	Load impedance 50mOhm, see Fig. 8-1
	max.	17A	Load impedance 50mOhm, see Fig. 8-1
Bonus time	typ.	4s	At 48V, 15A, duration until the output voltage dips,
	min.	3.5s	See Fig. 8-2
	max.	4.5s	
BonusPower [®] recovery time	typ.	7s	Overload free time to reset power manager, see Fig. 8-3

Peak current capability (up to several ms)

The power supply can deliver a peak current which is higher than the specified short-term current. This helps to start current demanding loads or to safely operate subsequent circuit breakers.

The extra current is supplied by the output capacitors inside the power supply. During this event, the capacitors will be discharged and causes a voltage dip on the output. Detailed curves can be found in chapter 27.2.

Peak current voltage dips	typ.	from 48V to 37V	At 20A for 20ms
	typ.	from 48V to 38.5V	At 40A for 2ms
	typ.	from 48V to 34.2V	At 40A for 5ms

Fig. 8-1 Output voltage vs. output current, typ.

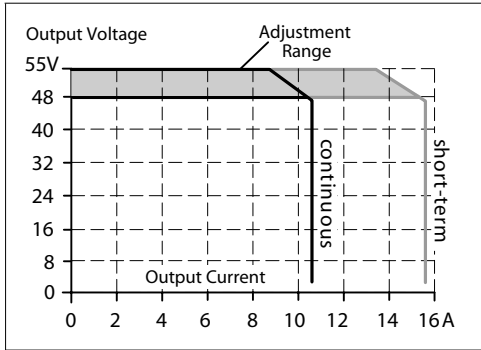

Fig. 8-2 Bonus time vs. output power

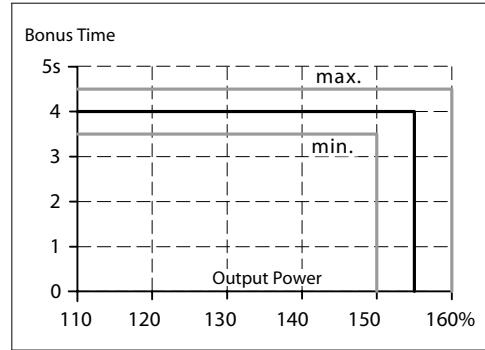
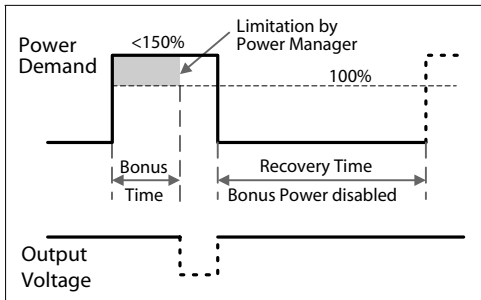

Fig. 8-3 BonusPower[®] recovery time



Bonus Power[®] is available as soon as power comes on and immedi

ately after the end of an output short circuit.

Fig. 8-4 BonusPower[®] after input turn-on

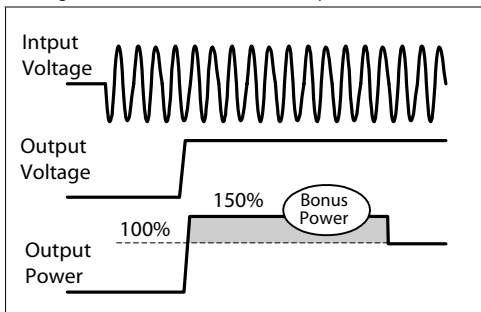
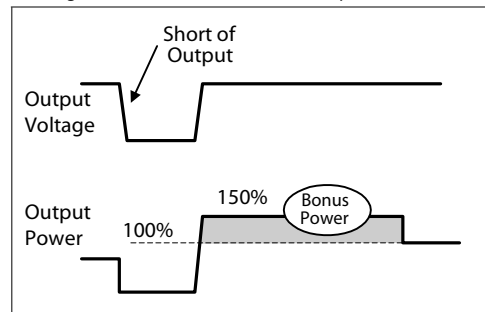

Fig. 8-5 BonusPower[®] after output short



9. HOLD-UP TIME

		3AC 400V	3AC 480V		
Hold-up Time	typ.	22ms	22ms	10A, 48V, see	Fig. 9-1
	typ.	44ms	44ms	5A, 48V, see	Fig. 9-1

Fig. 9-1 Hold-up time vs. input voltage

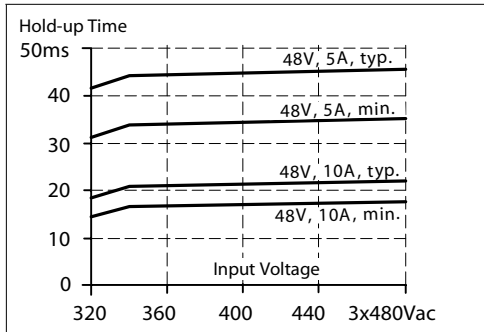
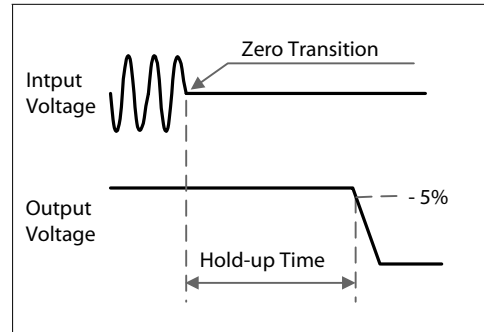

Fig. 9-2 Shut-down behavior, definitions



10. DC-OK RELAY CONTACT

This feature monitors the output voltage, which is produced by the power supply itself. It is independent of a back-fed voltage from a unit which is connected in parallel to the power supply output.

Contact closes	As soon as the output voltage reaches the adjusted output voltage.
Contact opens	As soon as the output voltage dips more than 10% below the adjusted output voltage. Short dips will be extended to a signal length of 250ms. Dips shorter than 1ms will be ignored.
Contact re-closes	As soon as the output voltage exceeds 90% of the adjusted voltage.
Contact ratings	max 60Vdc 0.3A, 30Vdc 1A, 30Vac 0.5A resistive load min 1mA at 5Vdc min. permissible load
Isolation voltage	See dielectric strength table in section 20

Fig. 10-1 DC-ok relay contact behavior

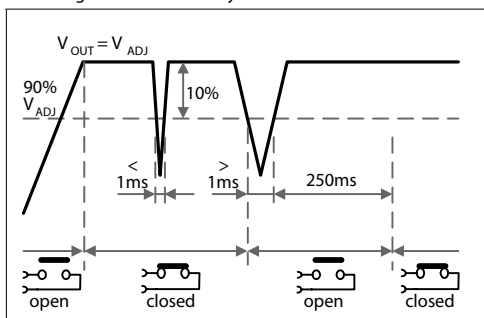

Note:

The DC-ok feature requires that the output voltage reaches the nominal (=adjusted) level after turn-on in order to function according to specification. If this level cannot be achieved, the overload lamp will be on and the DC-ok contact will be open. The overload signal will only shut off as soon as the adjusted voltage is reached. This is an important condition to consider particularly, if the load is a battery, the power supply is used in parallel or the power supply is used for N+1 redundant systems.

11. EFFICIENCY AND POWER LOSSES

		3AC 400V	3AC 480V	10A, 48V,
Efficiency	typ.	95.4%	95.0%	10A, 48V,
Power losses	typ.	23.1W	25.3W	10A, 48V,
	typ.	8.2W	10.0W	0A

Fig. 11-1 Efficiency vs. output current at 48V

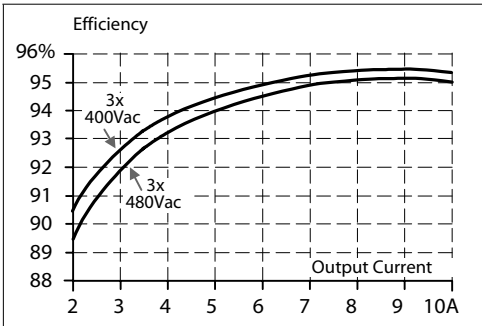

Fig. 11-2 Losses vs. output current at 48V

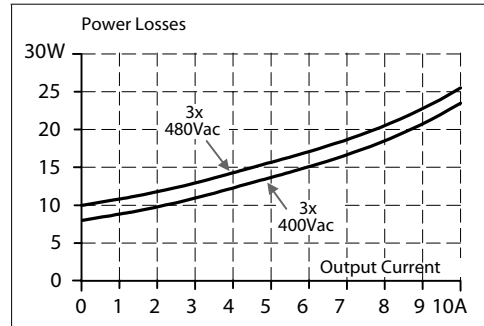

Fig. 11-3 Efficiency vs. input voltage, 48V, 10A

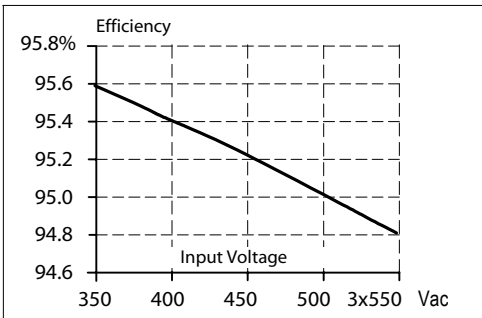
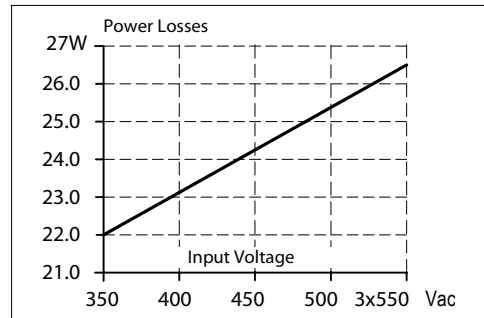
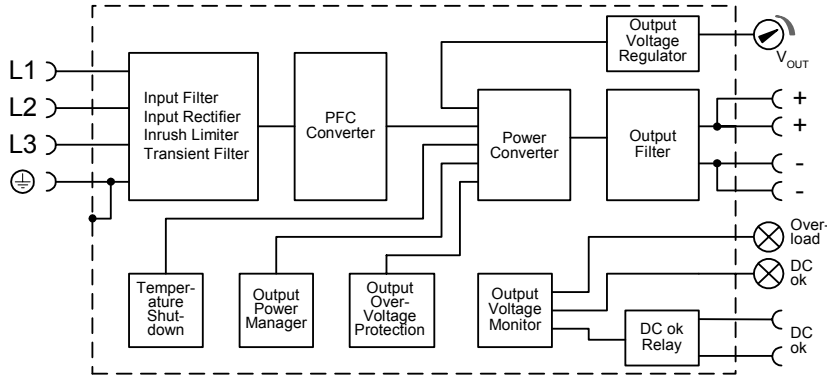

Fig. 11-4 Losses vs. input voltage, 48V, 10A



12. FUNCTIONAL DIAGRAM

Fig. 12-1 Functional diagram



13. FRONT SIDE AND USER ELEMENTS

Fig. 13-1 Front side

Output Terminals
Quick-connect spring-clamp terminals, no tools required

- + Positive output
- Negative (return) output
Dual pins per pole
- DC ok Relay contact (NO-contact)

480W Continuous power /
720W Peak power

Input Terminals
Quick-connect spring-clamp terminals, no tools required

- L1, L2, L3 Line inputs
- ⊕ ... PE (Protective Earth) input

See chapter 14 "Terminals and Wiring" to choose appropriate wire gauges

Output voltage potentiometer
(multi turn potentiometer)
Open the flap to tune the output voltage.
Factory setting: 48.0V

- DC-ok lamp (green)
- Overload lamp (red)

	Overload lamp	DC-ok lamp	DC-ok contact
Normal mode	OFF	ON	Closed
BonusPower [®] mode	OFF	ON	Closed
Overload ($V_{OUT} < 90\%$)	ON	OFF	Open
Short-circuit ($V_{OUT} = \text{ca. } 0V$)	ON	OFF	Open
Over-temperature	OFF	ON	Open
No input power	OFF	OFF	Open

DC-ok lamp and DC-ok contact function synchronized

14. T ERMINALS AND W IRING

Type	Bi-stable, quick-connect spring clamp terminals. I P20 Finger safe construction. Suitable for field- and factory in stallation. Shipped in open position.
Solid wire	0.5-6mm ²
Stranded wire	0.5-4mm ²
American wire gauge	20-10 AWG
Ferrules	Allowed, but not required
Wire stripping length	10mm / 0.4inch
Pull-out force	10AWG:80N, 12AWG:60N, 14AWG:50N, 16AWG:40N (according to UL486E)

Fig. 14-1 Connecting a wire

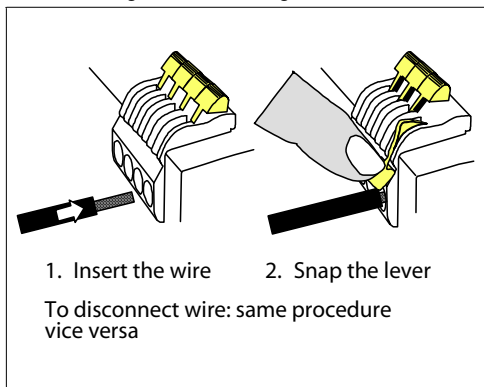

Instructions:

- Use appropriate copper cables that are designed for an operating temperature of:
60°C for ambient up to 45°C and
75°C for ambient up to 60°C minimum.
- Follow national installation codes and installation regulations!
- Ensure that all strands of a stranded wire enter the terminal connection!
- Up to two stranded wires with the same cross section are permitted in one connection point (except PE wire).
- Do not use the unit without PE connection.

15. R ELIABILITY

		3AC 400V	3AC 480V	
Lifetime expectancy	min.	51 000h	48 000h	40°C, 48V, 10A
	min.	89 000h	86 000h	40°C, 48V, 5A
	min.	144 000h	135 000h	25°C, 48V, 10A
MTBF SN 29500, IEC 61709		690 000h	670 000h	40°C, 48V, 10A
		1 194 000h	1 159 000h	25°C, 48V, 10A
MTBF MIL HDBK 217F		284 0 00h	271 000h	40°C, 48V, 10A, Ground Benign GB40
		389 000h	371 000h	25°C, 48V, 10A, Ground Benign GB25

The Lifetime expectancy shown in the table indicates the operating hours (service life) and is determined by the lifetime expectancy of the built-in electrolytic capacitors.

Lifetime expectancy is specified in operational hours. Lifetime expectancy is calculated according to the capacitor's manufacturer specification. The prediction model allows a calculation of up to 15 years from date of shipment.

MTBF stands for Mean Time Between Failure, which is calculated according to statistical device failures, and indicates reliability of a device. It is the statistical representation of the likelihood of a unit to fail and does not necessarily represent the life of a product.

16. EMC

The power supply is suitable for applications in industrial environment as well as in residential, commercial and light industry environment without any restrictions. CE mark is in conformance with EMC guideline 89/336/EEC and 93/68/EEC and the low-voltage directive (LVD) 73/23/EWG. A detailed EMC Report is available upon request

EMC Immunity	EN 61000-6-1 EN 61000-6-2		Generic standards	
Electrostatic discharge	EN 61000-4-2	Contact discharge Air discharge	8kV 15kV	Criterion A Criterion A
Electromagnetic RF field	EN 6100 0-4-3	80MHz-1GHz	10V/m	Criterion A
Fast transients (Burst)	EN 61000-4-4	Input lines Output lines	4kV 2kV	Criterion A Criterion A
Surge voltage on input	EN 61000-4-5	L1 → L2, L2 → L3, L1 → L3	2kV	Criterion A
Surge voltage on input	EN 61000-4-5	L1 / L2 / L3 → PE	4kV	Criterion A
Surge voltage on output	EN 61000-4-5	+ → - + / - → PE	500V 500V	Criterion A Criterion A
Conducted disturbance	EN 61000-4-6	0.15-80MHz	10V	Criterion A
Mains voltage dips Dip on all three phases	EN 61000-4-11	70% of 380Vac 40% of 380Vac 40% of 380Vac	266Vac, 10ms 152Vac, 100ms 152Vac, 1000ms	Criterion A Criterion C Criterion C
Mains voltage dips Dip on one phase	EN 61000-4-11	70% of 380Vac 40% of 380Vac 40% of 380Vac	266Vac, 10ms 152Vac, 100ms 152Vac, 1000ms	Criterion A Criterion A Criterion A
Voltage interruptions	EN 61000-4-11		0Vac, 5000ms	Criterion C
Voltage sags	SEMI F47 0200	Dips on two phases according to section 7.2. (SEMI F47-200)	304Vac, 1000ms 266Vac, 500ms 190Vac, 200ms	Criterion A Criterion A Criterion A
Powerful transients	VDE 0160	over entire load range	1300V, 1.3ms	Criterion A

Criteria:

A: Power supply shows normal operation behavior within the defined limits.

C: Temporary loss of function is possible. Power supply might shut down and restarts by itself. No damages or hazards for the power supply occur.

EMC Emission	EN 61000-6-3 and EN 61000-6-4	Generic standards
Conducted emission	EN 55011, EN 55022, FCC Part 15, CISPR 11, CISPR 22	Class B, input lines
Radiated emission	EN 55011, EN 55022	Class B
Harmonic input current	EN 61000-3-2	Fulfilled, active PFC
Voltage fluctuations, flicker	EN 61000-3-3	Fulfilled

This device complies with FCC Part 15 rules.

Operation is subjected to following two conditions: (1) this device may not cause harmful interference, and (2) this device must accept any interference received, including interference that may cause undesired operation.

Switching Frequencies	The power supply has three converters with three different switching frequencies included. One is nearly constant. The other two are input voltage and load dependent.	
Switching frequency 1	100kHz	Nearly constant
Switching frequency 2	30kHz to 90kHz	Input voltage and load dependent
Switching frequency 3	40kHz to 220kHz	Input voltage and load dependent

17. ENVIRONMENT

Operational temperature	-25°C to +70°C (-13°F to 158°F)	Reduce output power above +60°C	
Output de-rating	12W/°C	60-70°C (140°F to 158°F), see	Fig. 17-1
Storage temperature	-40 to +85°C (-40°F to 185°F)	Storage and transportation	
Humidity	5 to 95% r.H.	IEC 60068-2-30	Do not energize while condensation is present
Vibration sinusoidal	2-17.8Hz: ±1.6mm; 17.8-500Hz: 2g 2 hours / axis	IEC 60068-2-6	
Vibration random	0.5m ² (s ³) 2 hours / axis	IEC 60068-2-64	
Shock	30g 6ms, 20g 11ms 3 bumps / direction, 18 bumps in total	IEC 60068-2-27	
Altitude	0 to 6000m (0 to 20 000ft)	Reduce output power or ambient temperature above 2000m sea level.	
Output de-rating (for altitude)	30W/1000m or 5°C/1000m	above 2000m, see	Fig. 17-2
Over-voltage category	III II	EN 50178, altitudes up to 2000m Altitudes from 2000m to 6000m	
Degree of pollution	2	EN 50178, not conductive	

Fig. 17-1 Output current vs. ambient temp.,

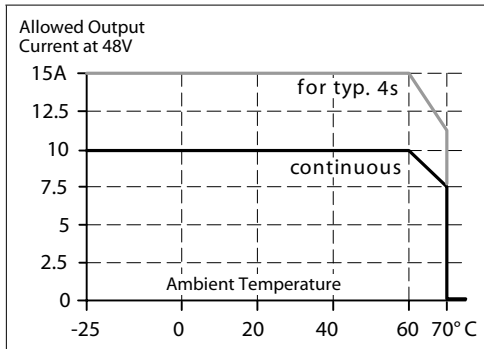
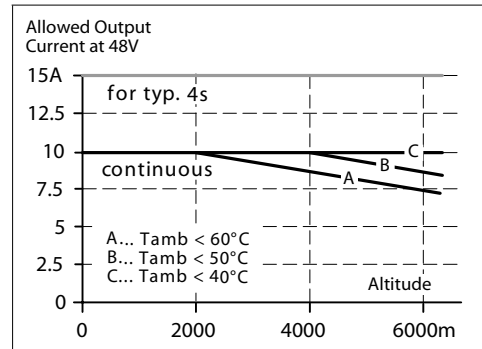

Fig. 17-2 Output current vs. altitude



The ambient temperature is defined as the air temperature 2cm below the unit.

18. PROTECTION FEATURES

Output protection	Electronically protected against overload, no-load and short-circuits
Output over-voltage protection	typ. 57Vdc max. 60Vdc In case of an internal power supply defect, a redundant circuitry limits the maximum output voltage. The output shuts-down and automatically attempts to restart.
Degree of protection	IP 20 EN/IEC 60529
Penetration protection	> 3.5mm e.g. screws, small parts
Over-temperature protection	yes Output shut-down with automatic restart
Input transient protection	MOV (Metal Oxide Varistor) and active transient filter
Internal input fuse	Not included See section 27.6

Note: In case of a protection event, audible noise may occur.

19. SAFETY

Input / output separation	SELV PELV double or reinforced insulation	IEC/EN 60950-1 EN 60204-1, EN 50178, IEC 60364-4-41
Class of protection	I	PE (Protective Earth) connection required
Isolation resistance	> 5MΩ	Input to output, 500Vdc
PE resistance	< 0.1Ω	Between housing and PE terminal
Touch current (leakage current)	typ. 0.38mA typ. 0.54mA < 0.47mA < 0.7mA	3x 400Vac, 50Hz, TN mains 3x 480Vac, 60Hz, TN mains 3x 440Vac, 50Hz, TN mains 3x 528Vac, 60Hz, TN mains

20. DIELECTRIC STRENGTH

Fig. 20-1 Dielectric strength

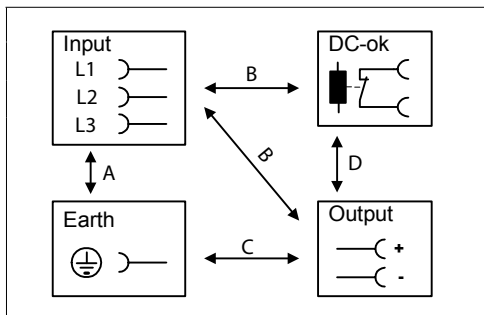

		A	B	C	D
Type test	60s	2500Vac	3000Vac	500Vac	500Vac
Factory test	5s	2500Vac	2500Vac	500Vac	500Vac
Field test	5s	2000Vac	2000Vac	500Vac	500Vac

Type tests and factory tests:

Conducted by the manufacturer. Do not repeat test in field!





Rules for field test:

Use appropriate test equipment which applies the voltage with a slow ramp! Connect L1, L2 and L3 together as well as all output poles.

The output voltage is floating and has no ohmic connection to ground.

To fulfill the PELV requirements according to EN60204-1 § 6.4. 1, we recommend that either the + pole, the - pole or any other part of the output circuit shall be connected to the protective earth system. This helps to avoid situations in which a load starts unexpectedly or can not be switched off any more when unnoticed earth faults occur.

21. APPROVALS

IEC 60950-1	IECEE CB SCHEME	CB Scheme, Information Technology Equipment
UL 508		LISTED E198865 listed for use in U.S.A. (UL 508) and Canada (C22.2 No. 14-95) Industrial Control Equipment
UL 60950-1		RECOGNIZED E137006 recognized for the use in U.S.A. (UL 60950-1) and Canada (C22.2 No. 60950) Information Technology Equipment, Level 5
UL 1604		RECOGNIZED E246877 recognized for use in U.S.A. (UL 1604) and Canada (C22.2 No. 213-M1987) Hazardous Location Class I Div 2 T4A Groups A,B,C,D and Class I Zone 2 Groups IIA, IIB and IIC
<p>The unit is suitable for use in Class I Division 2 Groups A, B, C, D locations as well as for Class I Zone 2 Groups IIA, IIB and IIC locations. Substitution of components may impair suitability for Class I Division 2 environment. Do not disconnect equipment unless power has been switched off. Wiring must be in accordance with Class I, Division 2 wiring methods of the National Electrical Code, NFPA 70, and in accordance with other local or national codes.</p>		
Marine		GL (Germanischer Lloyd) classified and ABS (American Bureau for Shipping) PDA for marine and offshore applications. Environmental category: C, EMC2

22. FILLED STANDARDS

EN 61558-2-17	Safety of Power Transformers
EN/IEC 60204-1	Safety of Electrical Equipment of Machines
EN/IEC 61131-2	Programmable Controllers
EN 50178	Electronic Equipment in Power Installations
SEMI F47-200	Ride-through compliance for semiconductor industry.

23. UNDESIRABLE SUBSTANCES

The unit does not release any silicone and is suitable for the use in paint shops.

Electrolytic capacitors included in this unit do not use electrolytes such as Quaternary Ammonium Salt Systems.

Plastic housings and other molded plastic materials are free of halogens, wires and cables are not PVC insulated.

The production material within our production does not include following toxic chemicals:

Polychlorized Biphenyl (PCB), Polychlorized Terphenyl (PCT), Pentachlorophenol (PCP), Polychlorinated naphthalene (PCN), Polybrom Biphenyl (PBB), Polybrom Biphenyl-oxide (PBO), Polybrominated Diphenylether (PBDE), Polychlorinated Diphenylether (PCDE), Polydibromophenyl Oxide (PBDO), Cadmium, Asbestos, Mercury, Silica

24. P HYSICAL DIMENSIONS AND W EIGHT

Weight	870g / 1.92lb
DIN-Rail	Use 35mm DIN-rails according to EN 60715 or EN 50022 with a height of 7.5 or 15mm. The DIN-rail height must be added to the depth (127mm) to calculate the total required installation depth.

Electronic files with mechanical data can be downloaded at www.pulspower.com

Fig. 24-1 Front view

Fig. 24-2 Side view

25. I NSTALLATION AND O PERATION I NSTRUCTIONS

Mounting Orientation:

Output terminal must be located on top and input terminal on the bottom. For other orientations see section 0.

Cooling:

Convection cooled, no forced cooling required. Do not cover ventilation grid (e.g. cable conduits) by more than 30%!

Installation clearances:

40mm on top, 20mm on the bottom, 5mm on the left and right side are recommended when loaded permanently with full power. In case the adjacent device is a heat source, 15mm clearance is recommended.

Risk of electrical shock, fire, personal injury or death!

Do not use the unit without proper earth connection (Protective Earth). Use the pin on the terminal block for earth connection and not one of the screws on the housing.

Turn power off before working on the power supply. Protect against inadvertent re-powering.

Make sure the wiring is correct by following all local and national codes.

Do not open, modify or repair the unit.

Use caution to prevent any foreign objects from entering into the housing.

Do not use in wet locations or in areas where moisture or condensation can be expected.

Service parts:

The unit does not contain any serviceable parts. If damage or malfunctioning should occur during operation, immediately turn power off and send unit to factory for inspection!

26. ACCESSORY

ZM1.WALL Wall mounting bracket

This bracket is used to mount Dimension units onto a flat surface without utilizing a DIN-Rail. The two aluminum brackets and the black plastic slide of the unit have to be detached, so that the two steel brackets can be mounted.

Fig. 26-1 ZM1.WALL Wall Mounting Bracket



Fig. 26-2 Assembled Wall Mounting Bracket

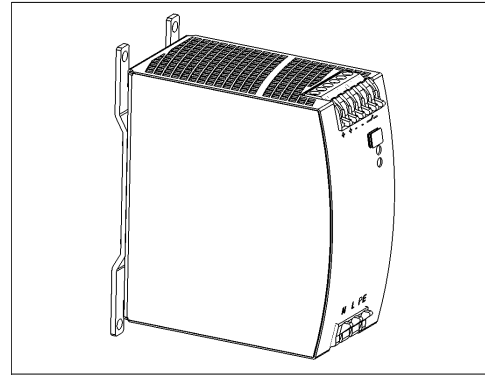

ZM14.SIDE Side mounting bracket

This bracket is used to mount Dimension units sideways with or without utilizing a DIN-Rail. The two aluminum brackets and the black plastic slide of the unit have to be detached, so that the steel brackets can be mounted.

For sideways DIN-rail mounting, the removed aluminum brackets and the black plastic slider need to be mounted on the steel bracket.

Fig. 26-3 ZM14.SIDE Side Mounting Bracket
Panel Mount

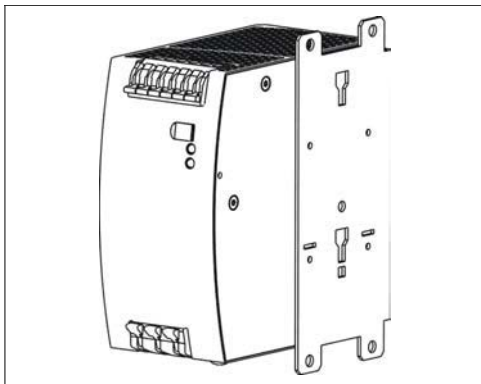
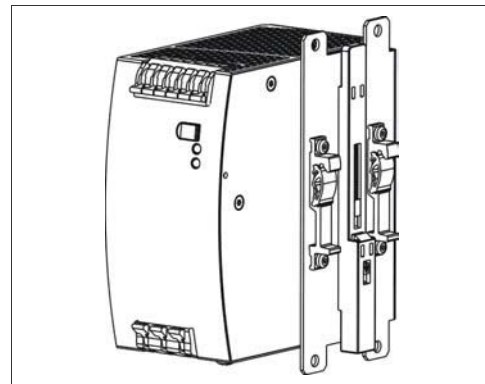

Fig. 26-4 ZM14.SIDE Side Mounting Bracket
DIN-Rail Mount



27. APPLICATION NOTES

27.1. REPETITIVE PULSE LOADING

Typically, a load current is not constant. It varies over time. For pulse load compatibility, following rules must be met:

- The pulse power demand must be below 150% of the nominal power.
- The duration of the pulse power must be shorter than the allowed Bonus Time. (see output section)
- The average (R.M.S.) output current must be below the specified continuous output current. If the R.M.S. current is higher, the unit will respond with a thermal shut-down after a while. Use the max. duty cycle curve (Fig. 27-2) to check if the average output current is below the nominal current.
- The duty cycle must be below 0.75.
- For altitudes higher than 2000m reduce the pulse loading (15W/1000m) or the ambient temperature (5°C/1000m)

Fig. 27-1 Repetitive pulse loads, definitions

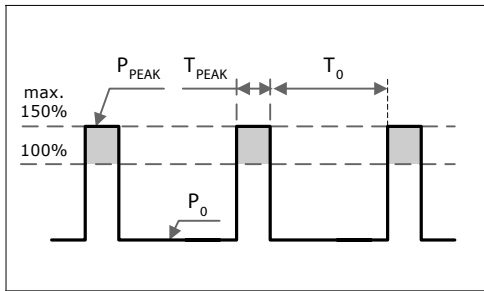

- P₀ Base load (W)
- P_{PEAK} Pulse load (above 100%)
- T₀ Duration between pulses (s)
- T_{PEAK} Pulse duration (s)

Fig. 27-2 Max. Duty Cycle Curve

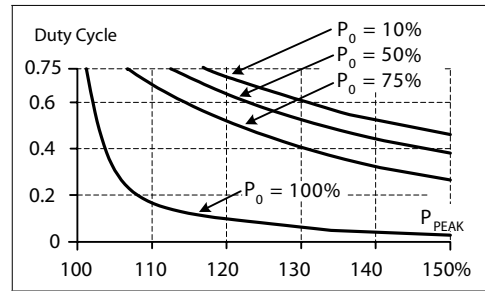

$$\text{DutyCycle} = \frac{T_{\text{peak}}}{T_{\text{peak}} + T_0}$$

$$T_0 = \frac{T_{\text{peak}} - (\text{DutyCycle} \times T_{\text{peak}})}{\text{DutyCycle}}$$

Utilizing the Max. Duty Cycle Curve:

Example to determine the repetition rate of pulses without dipping of the output voltage:

Parameters of application: _____

Determining the repetition rate: _____

Pulse length is T_{PEAK} = 1s

- make a vertical line at P_{PEAK} = 150%
- make a horizontal line where the vertical line crosses the P₀ = 50% curve
- Read the Max. Duty Cycle from the Duty Cycle-axis (= 0.37)
- Calculate the min. pause (base load) length T₀:

Steady state load P₀ = 120W
(= 50% of I_{RATED})

$$T_0 = \frac{T_{\text{peak}} - (\text{DutyCycle} \times T_{\text{peak}})}{\text{DutyCycle}} = \frac{1\text{s} - (0.37 \times 1\text{s})}{0.37} = 1.7\text{s}$$

Peak load P_{PEAK} = 360W
(= 150% of I_{RATED})

- Pulse length = 1s, min. pause length = 1.7s
- Max. repetition rate = pulse length + pause length = 2.7s

More examples for pulse load compatibility:

P _{PEAK}	P ₀	T _{PEAK}	T ₀
720W	480W	1s	>25s
720W	0W	1s	>1.3s
600W	240W	1s	>0,75s

P _{PEAK}	P ₀	T _{PEAK}	T ₀
720W	240W	0.1s	>0.16s
720W	240W	1s	>1.6s
720W	240W	3s	>4.9s

27.2. PEAK CURRENT CAPABILITY

Solenoids, contactors and pneumatic modules often have a steady state coil and a pick-up coil. The inrush current demand of the pick-up coil is several times higher than the steady state current and usually exceeds the nominal output current (including the Bonus Power [®]) The same situation applies, when starting a capacitive load.

Branch circuits are often protected with circuit breakers or fuses. In case of a short or an overload in the branch circuit, the fuse needs a certain amount of over-current to trip or to blow. The peak current capability ensures the safe operation of subsequent circuit breakers.

Assuming the input voltage is turned on before such an event, the built-in large sized output capacitors inside the power supply can deliver extra current. Discharging this capacitor causes a voltage dip on the output. The following two examples show typical voltage dips:

ent, the built-in large sized output capacitors inside the capacitor causes a voltage dip on the output. The following

Fig. 27-3 Peak load 20A for 50ms, typ.

Fig. 27-4 Peak load 40A for 5ms, typ.

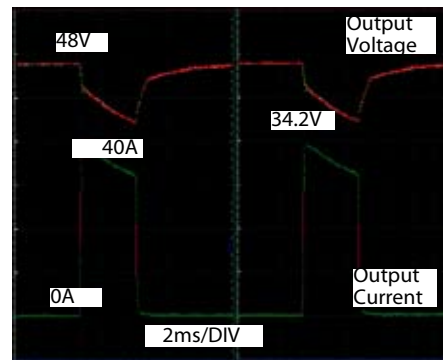
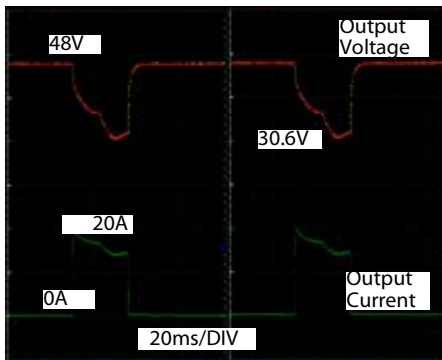

Peak load 20A (resistive) for 50ms
Output voltage dips from 48V to 30.6V.

Peak load 40A (resistive) for 5ms
Output voltage dips from 48V to 34.2V.

Please note: The DC-OK relay triggers when the voltage dips more than 10% for longer than 1ms.

27.3. BACK-FEEDING LOADS

Loads such as decelerating motors and inductors can feed voltage back to the power supply. This feature is also called return voltage immunity or resistance against Back- E.M.F. (Electro Magnetic Force).

This power supply is resistant and does not show malfunctioning when a load feeds back voltage to the power supply. It does not matter, whether the power supply is on or off.

The maximum allowed feedback voltage is 58Vdc. The absorbing energy can be calculated according to the built-in large sized output capacitor which is specified in chapter 8.

27.4. CHARGING OF BATTERIES

The power supply can be used to charge lead-acid or maintenance free batteries. (Four 12V batteries in series)

Instructions for charging batteries:

a) Set output voltage (measured at the battery) very precisely to the end-of-charge voltage.

End-of-charge voltage	55.6V	55.0V	54.3V	53.6V
Battery temperature	10°C	20°C	30°C	40°C

b) Use a 25A circuit breaker (or blocking diode) between the power supply and the battery.

c) Ensure that the output current of the power supply is below the allowed charging current of the battery.

d) Use only matched batteries when putting 12V types in series.

e) The return current to the power supply is typ. 14mA at 55Vdc when the power supply is switched off (except in case a blocking diode is utilized).

27.5. OUTPUT CIRCUIT BREAKERS

Standard miniature circuit breakers (MCBs) can be used for branch protection. Ensure that the MCB is rated for DC voltage, too. The following tests show which circuit breakers the power supply typically trips.

Circuit breakers have huge tolerances in their tripping behavior. Therefore, these typical tests can only be used as a recommendation or for comparing two different power supplies. Furthermore, the loop impedance has a major influence on whether a breaker trips or not. Two tests were performed, representing typical situations:

Test 1: Short circuit with S1 on the power supply end of the cable (loop impedance approx. 20mOhm)

Fig. 27-5 Branch protectors, test circuit 1

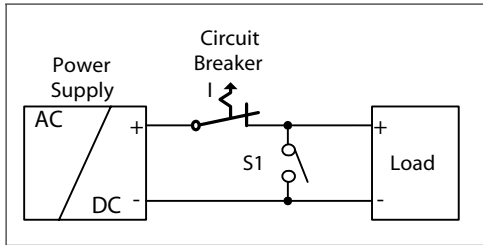

Parameters:

Input voltage: 3x 400Vac, load current: 0A
Tripping time shorter than 5s.

The following circuit breaker tripped during the test:

- A- or Z- Characteristic: equal or smaller 10A
- B- Characteristic: equal or smaller 6A
- C- Characteristic: equal or smaller 4A

Test 2: Short circuit with S1 on the load end (additional impedance included; represents longer load wire length).

Fig. 27-6 Branch protectors, test circuit 2

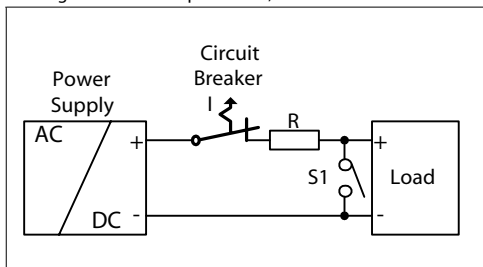

Parameters:

Input voltage: 3x 400Vac, load current: 0A
Tripping time shorter than 5s.

The following circuit breaker tripped during the test:

- A- or Z- Characteristic: $\leq 16A$ and $R < 120m\Omega$
- B- Characteristic: $\leq 6A$ and $R < 180m\Omega$
- C- Characteristic: $\leq 6A$ and $R \leq 220m\Omega$

What does this resistance mean in wire length?

	0.5mm ²	0.7mm ²	1.0mm ²	1.5mm ²	2.5mm ²	4.0mm ²
120mOhm	3.3m	4.7m	6.7m	10.0m	16.7m	26.7m
180mOhm	5.0m	7.0m	10.0m	15.0m	25.1m	40.1m
220mOhm	6.1m	8.6m	12.3m	18.4m	30.6m	49.0m

Example:

Which wire gauge must be used to trip a B-Characteristic circuit breaker with a rating of 6A? The load wire length is 21m.

Answer: A 6A B-Characteristic circuit breaker requires a loop impedance of less than 180mOhm (test results). The wire length table shows that up to 25.1m wire with a cross section of 2.5mm² are below 180mOhm. A wire not smaller than 2.5mm² shall be used.

27.8. PARALLEL USE TO INCREASE OUTPUT POWER

Power supplies can be paralleled to increase the output power.

Fig. 27-10 Schematic for parallel operation

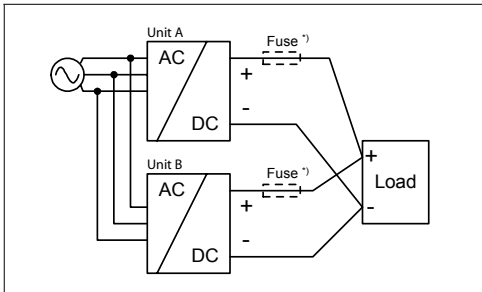

Instructions for parallel use:

- Use only power supplies from the same series (Q-Series).
- Adjust the output voltages of all power supplies to approximately the same value ($\pm 500\text{mV}$). Otherwise, the DC-ok signal might not work properly.
- A fuse (or diode) on the output is only required if more than three units are connected in parallel.
- Keep an installation clearance of 15mm (left / right) between two power supplies and avoid installing the power supplies on top of each other.

27.9. PARALLEL USE FOR REDUNDANCY

Power supplies can be paralleled for redundancy to gain a higher system availability. Redundant systems require a certain amount of extra power to support the load in case one power supply unit fails. The simplest way is to put two Q-Series power supplies in parallel. This is called a 1+1 redundancy. In case one power supply unit fails, the other one is automatically able to support the load current without any interruption. Redundant systems for a higher power demand are usually built in a N+1 method. E.g. Five power supplies, each rated for 10A are paralleled to build a 40A redundant system.

Please note: This simple way to build a redundant system does not cover failures such as an internal short circuit in the secondary side of the power supply. In such a virtually nearly impossible case, the defect unit becomes a load for the other power supplies and the output voltage can not be maintained any more. This can only be avoided by utilizing decoupling diodes which are included in the decoupling module YR2.DIODE.

Recommendations for building redundant power systems:

- Use separate input fuses for each power supply.
- Monitor the individual power supply units. A DC-ok lamp and a DC-ok contact is already included in the units. This feature reports a faulty unit.
- When possible, connect each power supply to different phases or circuits.
- It is desirable to set the output voltages of all power supplies to the same value to avoid a false DC-ok signal.

27.10.D EASY CHAINING OF OUTPUTS

Daisy chaining (jumping from one power supply output to the next) is allowed as long as the maximum current through one terminal pin does not exceed 25A. If the current is higher, use a separate distribution terminal block.

Fig. 27-11 Daisy chaining of outputs

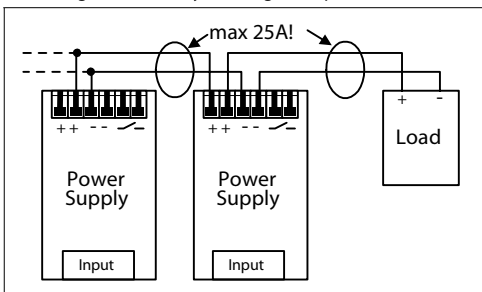
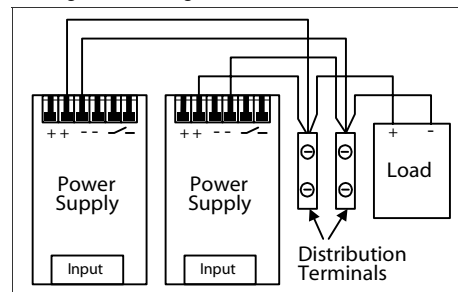

Fig. 27-12 Using distribution terminals



27.11.S ERIES OPERATION

The power supply can be put in series to increase the output voltage.

Fig. 27-13 Schematic for series operation

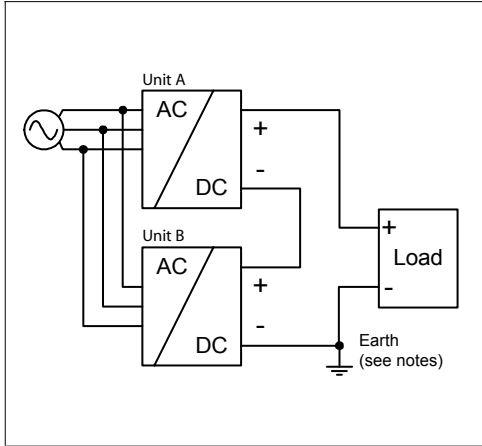

Instructions for use in series:

- It is possible to connect as many units in series as needed, providing the sum of the output voltage does not exceed 150Vdc.
- Voltages with a potential above 60Vdc are not SELV any more and can be dangerous. Such voltages must be installed with a protection against touching.
- For serial operation use power supplies of the same type.
- Earthing of the output is required when the sum of the output voltage is above 60Vdc.
- Keep an installation clearance of 15mm (left/right) between two power supplies and avoid installing the power supplies on top of each other.

Note: Avoid return voltage (e.g. from a decelerating motor or battery) which is applied to the output terminals.

27.12.I NDUCTIVE AND CAPACITIVE LOADS

The unit is designed to supply any kind of load, including unlimited capacitive and inductive loads.

27.13.U SE IN A TIGHTLY SEALED ENCLOSURE

When the power supply is installed in a tightly sealed enclosure, the temperature inside the enclosure will be higher than outside. The inside temperature defines the ambient temperature for the power supply.

Results from such an installation:

Power supply is placed in the middle of the box, no other heat producer inside the box

Enclosure: Rittal Typ IP66 Box PK 9519 100, plastic, 180x180x165mm

Load: 48V, 8A; (=80%) load is placed outside the box

Input: 3x 400Vac

Temperature inside enclosure: 55.1°C (in the middle of the right side of the power supply with a distance of 2cm)

Temperature outside enclosure: 24.9°C

Temperature rise: 30.2K

Mounting Orientations

Mounting orientations other than input terminals on the bottom and output on the top require a reduction in continuous output power or a limitation in the max. allowed ambient temperature. The amount of reduction influences the lifetime expectancy of the power supply. Therefore, two different derating curves for continuous operation can be found below:

Curve A1 Recommended output current.

Curve A2 Max allowed output current (results approx. in half the lifetime expectancy of A1).

Fig. 27-12
Mounting
Orientation A
Standard
Orientation

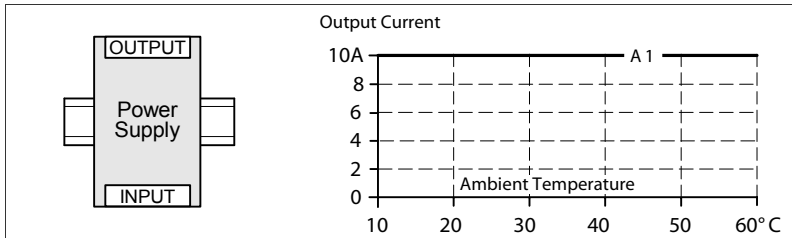

Fig. 27-13
Mounting
Orientation B
(Upside down)

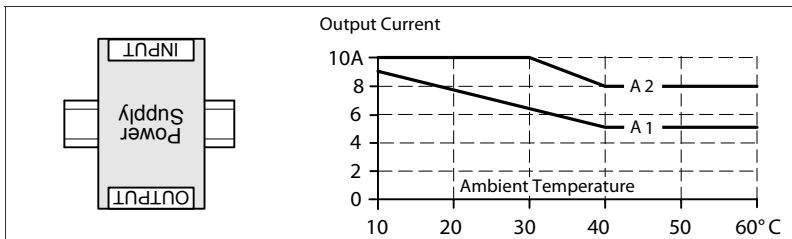

Fig. 27-14
Mounting
Orientation C
(Table-top
mounting)

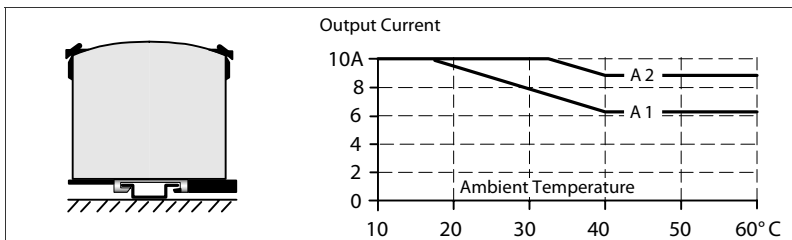

Fig. 27-15
Mounting
Orientation D
(Horizontal cw)

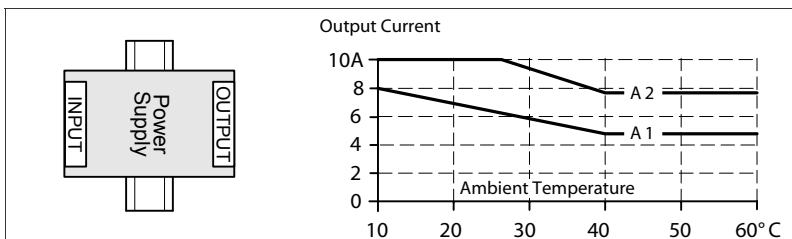

Fig. 27-16
Mounting
Orientation E
(Horizontal ccw)

