



POWER SUPPLY

- 600Vdc Input Voltage
- Optimized for Intermediate DC -busses of Drive Systems
- Two Input Fuses for 600Vdc Included
- Efficiency up to 95%
- Width only 65mm
- 125% Peak Load Capability
- Active Input Transient Filter
- Full Power Between -25°C and +60°C
- Minimal Inrush Current
- DC-OK Relay Contact
- Quick-connect Spring-clamp Terminals
- 3 Year Warranty

1. GENERAL DESCRIPTION

Modern machines typically use maintenance-free AC-motors which are controlled by frequency converters or servo amplifiers. Such devices have an intermediate DC-bus where all individual drives are connected.

The QTD20 power supply can be connected directly to the intermediate DC-bus. In case of a mains failure, the QTD20 utilizes the kinetic energy from the motor and the DC-bus capacitors to keep the controls and other important peripheral equipment operational until the motor is in a complete stop position. With the QTD20 mains failure can be handled with no problems.

Intermediate DC-buses are not usually filtered and have high EMI noise superimposed. The QTD20 has a very robust input stage and an appropriate input filter included.

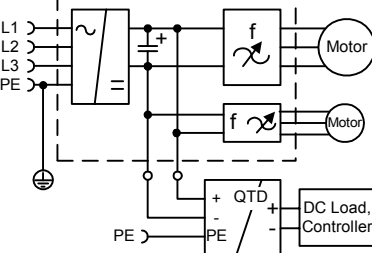

Additionally, the QTD20 is UL 508 approved and is equipped with input fuses which are rated and tested for 600V applications.

2. SHORT-FORM DATA

Output voltage	DC 24V	
Adjustment range	24-28V	
Output current	20A	continuous, 24V
	25A	for typ. 4s, 24V
Output power	480W	continuous, 24V
	600W	for typ. 4s, 24V
Output ripple	< 100mVpp	20Hz to 20MHz
Input voltage	DC 600V	
	480-840Vdc	continuous
	360-480Vdc	< 1 minute
	840-900Vdc	or with reduced output current
Input current	0.85A	600Vdc, 24V, 20A
Inrush current	typ. 1.5A peak	
Efficiency	95.0%	at 600Vdc
Losses	25.5W	at 600Vdc
Temperature range	-25°C to +70°C	operational
Derating	12W/°C	+60 to +70°C
Hold-up time	typ. 22ms	at 600Vdc
Dimensions	65x124x127mm	wxhxd

3. ORDER NUMBERS

Power Supply	QTD20.241	600V → 24V Converter
Accessory	ZM1.WALL	Wall mount bracket
	ZM14.SIDE	Side mount bracket
	YR2.DIODE	Decoupling module
	UF20.241	Buffer unit

4. MARKINGS



INDEX PAGE

- 1. General Description1
- 2. Short-form Data1
- 3. Order Numbers.....1
- 4. Markings.....1
- 5. Input3
- 6. Input Inrush Current4
- 7. Output5
- 8. Hold-up Time.....7
- 9. DC-OK Relay Contact7
- 10. Efficiency and Power Losses.....8
- 11. Functional Diagram.....9
- 12. Front Side and User Elements.....9
- 13. Terminals and Wiring.....10
- 14. Reliability10
- 15. EMC.....11
- 16. Environment.....12
- 17. Protection Features13
- 18. Safety13
- 19. Dielectric Strength13

INDEX PAGE



- 20. Approvals..... 14
- 21. Fulfilled Standards..... 14
- 22. Used Substances 14
- 23. Physical Dimensions and Weight 15
- 24. Installation and Operation Instructions 15
- 25. Accessories 16
- 26. Application Notes..... 17
 - 26.1. Repetitive Puls e Loading..... 17
 - 26.2. Back-feeding Loads 18
 - Charging of Batteries 18
 - 26.3. Output Circuit Breakers 19
 - 26.4. Parallel Use to Increase Output Power . 20
 - 26.5. Parallel Use for Redundancy..... 20
 - 26.6. Daisy Chaining of Outputs..... 20
 - 26.7. Series Operation..... 21
 - 26.8. Inductive and Capacitive Loads 21
 - 26.9. Use in a Tightly Sealed Enclosure 21
 - 26.10. Mounting Orientations..... 22

INTENDED USE

The power supply shall only be installed and put into operation by qualified personnel.

This power supply is designed for installation in an enclosure and is intended for the general use, such as in industrial control, office, communication, and instrumentation equipment. Do not use this device in aircraft, trains and nuclear equipment, where malfunctioning of the power supply may cause severe personal injury or threaten human life.

TERMINOLOGY AND ABBREVIATIONS

PE and  symbol	PE is the abbreviation for Protective Earth and has the same meaning as the symbol  .
Earth, Ground	This document uses the term "earth" which is the same as the U.S. term "ground".
T.b.d.	To be defined, value or description will follow later.
DC 600V	A figure displayed with the AC or DC before the value represents a nominal voltage with standard tolerances (usually ±15%) included. E.g.: DC 12V describes a 12V battery regardless whether it is charged (13.7V) or discharged (10V)
600Vdc	A figure with the unit (Vdc) at the end is a value which is used during testing without any additional tolerances included.

DISCLAIMER

The information presented in this document is believed to be accurate and reliable and may change without notice.

5. INPUT

Input	nom.	DC 600V	
Input voltage range	nom.	480-840Vdc	continuous operation
		360-480Vdc	max. 60 seconds or with de-rating according to Fig. 7-2
		840-900Vdc	max. 60 seconds or with de-rating according to Fig. 7-2
		1000Vdc	Absolute maximum input voltage with no damage to the power supply. Above 900Vdc, the output will switch off and will turn-on again when the voltage falls below 850V.
Allowed voltage between input and earth (ground)	max.	600V R.M.S.	continuously allowed
		±900V	peak value, allowed for transients
Slew rate for voltage between input and earth (ground)	max.	1000V/μs	
Allowed input ripple voltage	max.	50Vpp	50Hz-40kHz
Turn-on voltage	typ.	450Vdc	Steady-state value, see Fig. 5-1
Shut-down voltage	typ.	325Vdc	Steady-state value, see Fig. 5-1
Input current	typ.	0.85A	At 600Vdc input, 24V, 20A, see Fig. 5-3
Start-up delay	typ.	350ms	See Fig. 5-2
Rise time	typ.	70ms	0mF, 24V, 20A, see Fig. 5-2
	typ.	110ms	20mF, 24V, 20A, see Fig. 5-2
Turn-on overshoot	max.	500mV	See Fig. 5-2

External capacitors on the input voltage bus are allowed without any limitations.

Fig. 5-1 Input voltage range

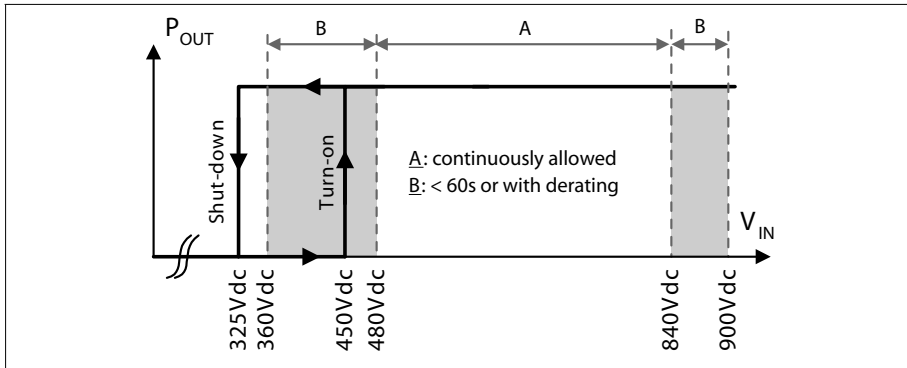

Fig. 5-2 Turn-on behavior, definitions

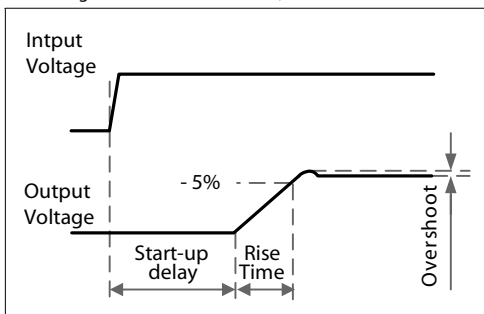
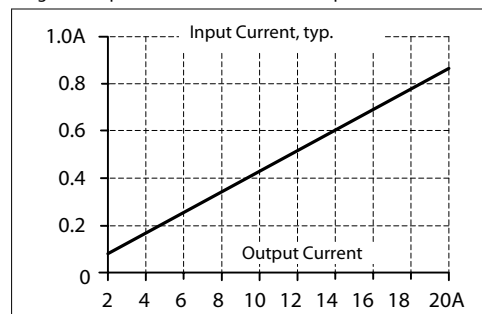

Fig. 5-3 Input current at 600Vdc vs. output load



6. INPUT INRUSH CURRENT

An active inrush limitation circuit limits the input inrush current after turn-on of the input voltage and after short input voltage interruptions.

The charging current into the EMI suppression capacitors is disregarded for the first millisecond after switch-on.

		600Vdc	
Inrush current	max.	3A _{peak}	-25°C to +70°C
	typ.	1.5A _{peak}	-25°C to +70°C
Inrush energy	max.	1A ² s	-25°C to +70°C
Inrush delay	typ.	350ms	

Fig. 6-1 Input inrush current, typical behavior

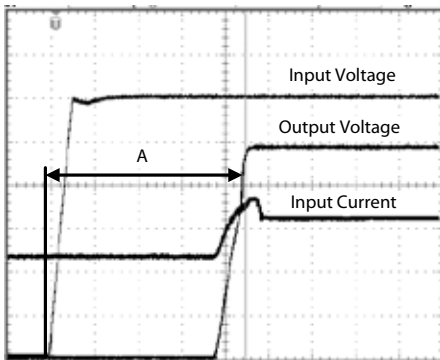

A: Inrush delay

Input: 600Vdc
 Output: 24V, 20A
 Ambient: 25°C
 Upper curve: Input voltage 100V / DIV
 Medium curve: Output voltage 5V / DIV
 Lower curve: Input current 1A / DIV
 Time basis: 100ms / DIV

7. O UTPUT

Output voltage	nom.	24V	
Adjustment range	min.	24-28V	guaranteed, multi turn potentiometer
	max.	30V	at clockwise end position of potentiometer
Factory setting		24.1V	±0.2%, at full load, cold unit
Line regulation	max.	10mV	480Vdc → 840Vdc → 480Vdc, 24V, 20A
Load regulation	max.	100mV	static value, 0A → 20A → 0A
Ripple and noise voltage	max.	100mVpp	20Hz to 20MHz, 50Ohm
Output capacitance	typ.	1 000µF	The energy of the bulk capacitor on the input side will be transferred to the output to supply short load peaks.
Continuous output power capability			
Output current	nom.	20A	at 24V see Fig. 7-1 , Note: derating below 480Vdc and above 840Vdc, see Fig. 7-2
	nom.	17.5A	at 28V see Fig. 7-1 , a derating is required below 480Vdc and above 840Vdc
Output power	nom.	480W	at 24-28V, between 480Vdc and 840Vdc Note: derating below 480Vdc and above 840Vdc, see Fig. 7-2
Short-circuit current	min.	20A	load impedance 50mOhm, see Fig. 7-1
	max.	23A	load impedance 50mOhm, see Fig. 7-1

BonusPower®, short term output power capability (up to typ. 4s)

The power supply is designed to support loads with a higher short-term power requirement without damage or shutdown. The short-term duration is hardware controlled by an output power manager. The BonusPower® is repeatedly available. Detailed information can be found in chapter 26.1 .

Once BonusPower® has been stopped by the output power limiter, a timer disables the next BonusPower® capability. This timer (recovery time) will start as soon as the output voltage reaches the adjusted value again, which usually happens after the load has been reduced.

Output current	nom.	25A	at 24V, between 480Vdc and 840Vdc, see Fig. 7-1 Note: derating below 480Vdc and above 840Vdc, see Fig. 7-2
	nom.	21.4A	at 28V, between 480Vdc and 840Vdc, see Fig. 7-1 a derating is required below 480Vdc and above 840Vdc
Output power	nom.	600W	24-28V, short term
Short-circuit current	min.	25A	load impedance 50mOhm, see Fig. 7-1
	max.	28A	load impedance 50mOhm, see Fig. 7-1
Bonus time	typ.	4s	at 24V, > 25A, duration until the output voltage dips,
	min.	3.5s	see Fig. 7-3
	max.	4.5s	
BonusPower® recovery time	typ.	7s	Overload free time to reset power manager, see Fig. 7-4

Fig. 7-1 Output voltage vs. output current, typ.

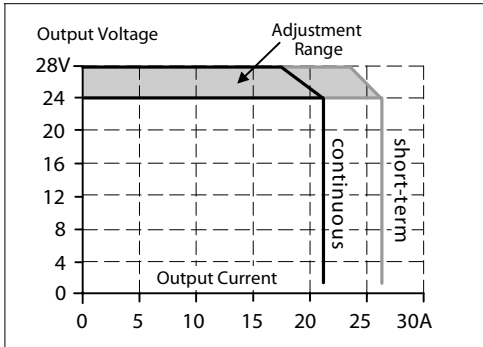

Fig. 7-2 Output current vs. input voltage

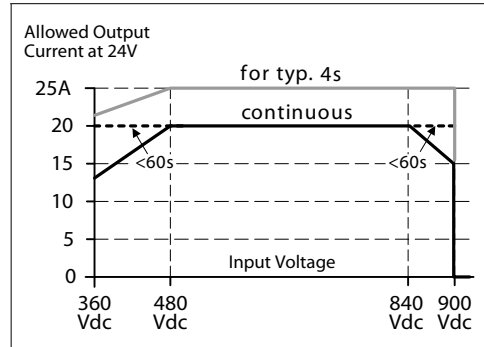

Fig. 7-3 Bonus time vs. output power

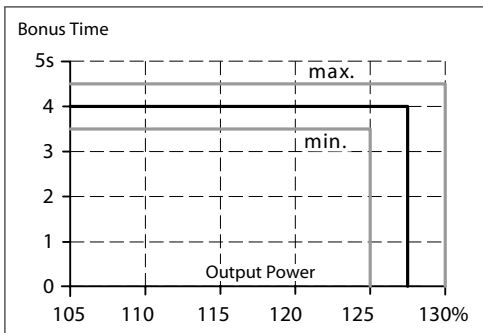
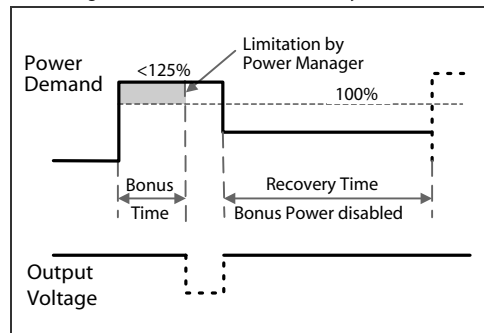

Fig. 7-4 BonusPower[®] recovery time



Bonus Power[®] is available as soon as power comes on and immedi

ately after the end of an output short circuit.

Fig. 7-5 BonusPower[®] after input turn-on

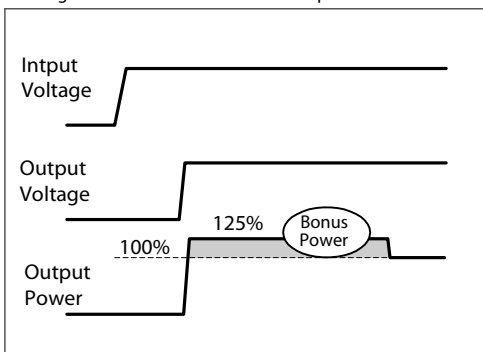
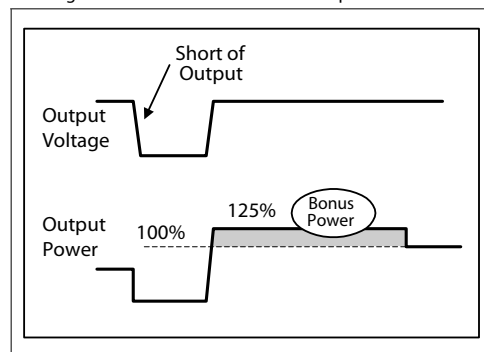

Fig. 7-6 BonusPower[®] after output short



8. HOLD-UP TIME

Hold-up Time	typ.	22ms	20A, 24V, see	Fig. 8-1
	typ.	44ms	10A, 24V, see	Fig. 8-1

Fig. 8-1 Hold-up time vs. input voltage

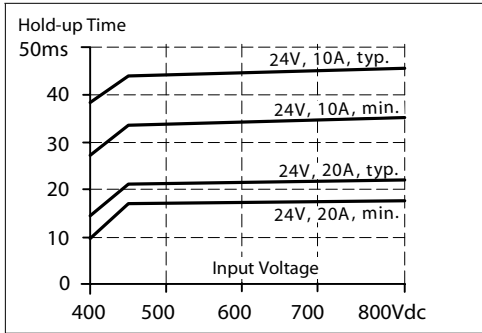
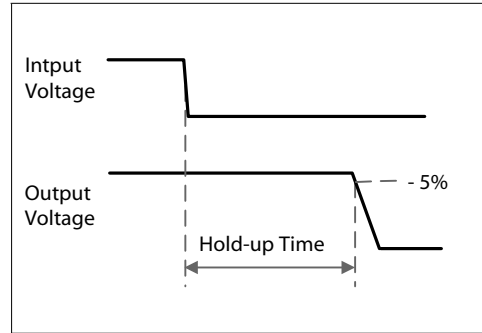

Fig. 8-2 Shut-down behavior, definitions



9. DC-OK R ELAY CONTACT

This feature monitors the output voltage, which is produced by the power supply itself. It is independent of a back-fed voltage from a unit which is connected in parallel to the power supply output.

Contact closes	As soon as the output voltage reaches the adjusted output voltage.
Contact opens	As soon as the output voltage dips more than 10% below the adjusted output voltage. Short dips will be extended to a signal length of 250ms. Dips shorter than 1ms will be ignored.
Contact re-closes	As soon as the output voltage exceeds 90% of the adjusted voltage.
Contact ratings	max 42.4Vdc 0.3A, 30Vdc 1A, 30Vac 0.5A resistive load min 1mA at 5Vdc min. permissible load
Isolation voltage	See dielectric strength table in section 19

Fig. 9-1 DC-ok relay contact behavior

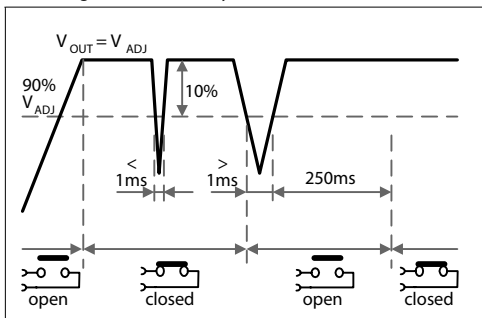

Note:

The DC-ok feature requires that the output voltage reaches the nominal (=adjusted) level after turn-on in order to function according to specification. If this level cannot be achieved, the overload LED will be on and the DC-ok contact will be open. The overload signal will only shut off as soon as the adjusted voltage is reached. This is an important condition to consider particularly, if the load is a battery, the power supply is used in parallel or the power supply is used for N+1 redundant systems.

10. EFFICIENCY AND POWER LOSSES

600Vdc			
Efficiency	typ.	95.0%	20A, 24V,
Power losses	typ.	25.5W	20A, 24V,
	typ.	7.7W	0A

Fig. 10-1 Efficiency vs. output current at 24V

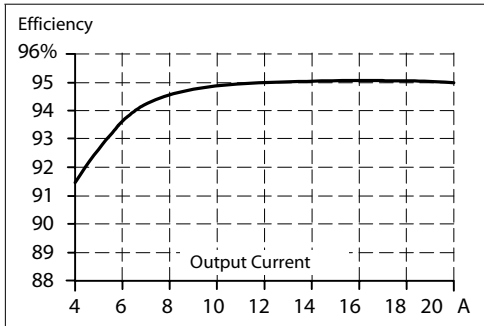

Fig. 10-2 Losses vs. output current at 24V

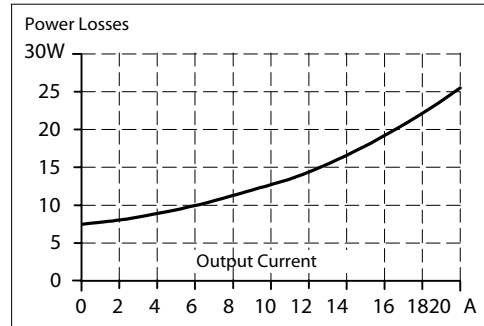

Fig. 10-3 Efficiency vs. input voltage, 24V, 20A

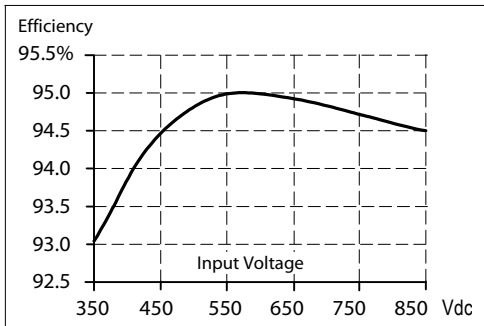
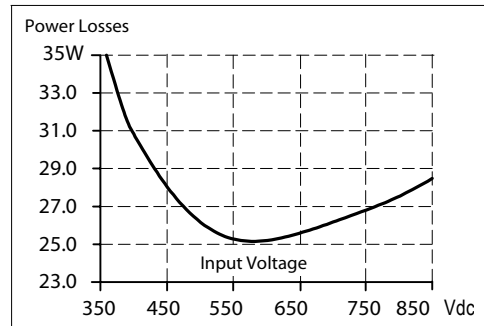
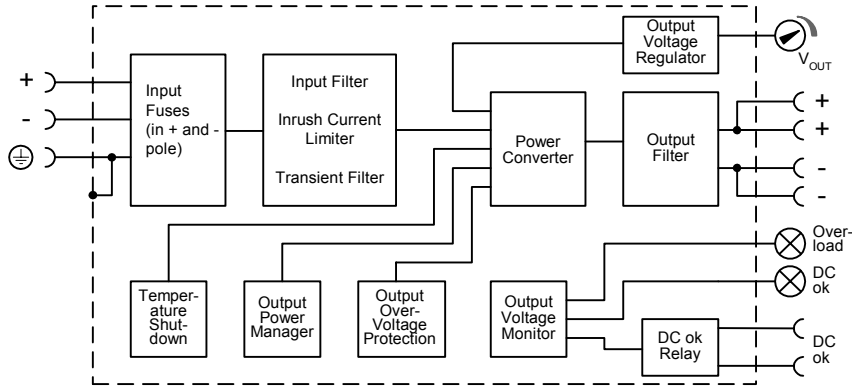

Fig. 10-4 Losses vs. input voltage, 24V, 20A



11. FUNCTIONAL DIAGRAM

Fig. 11-1 Functional diagram



12. FRONT SIDE AND USER ELEMENTS

Fig. 12-1 Front side

Output Terminals
Quick-connect spring-clamp terminals, no tools required

- + Positive output
- Negative (return) output
Dual pins per pole
- DC ok Relay contact (NO-contact)

Input Terminals
Quick-connect spring-clamp terminals, no tools required

- + - Power input
- ⊕ PE (Protective Earth) input

See chapter 13 "Terminals and Wiring" to choose appropriate wire gauges

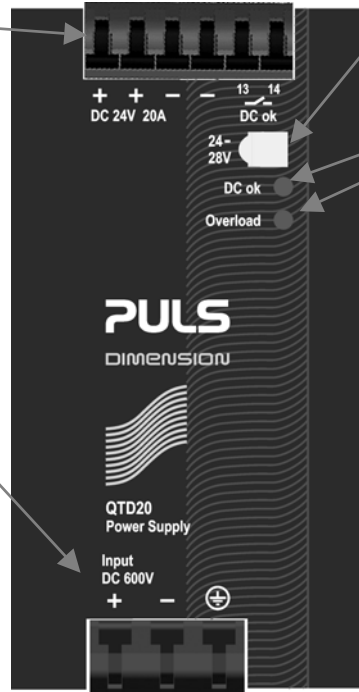

Output voltage potentiometer
(multi turn potentiometer)
Open the flap to set the output voltage.
Factory setting: 24.1V

- DC-ok LED (green)
- Overload LED (red)

	Overload LED	DC-ok LED	DC-ok contact
Normal mode	OFF	ON	Closed
BonusPower [®] mode	OFF	ON	Closed
Overload ($V_{OUT} < 90\%$)	ON	OFF	Open
Short-circuit ($V_{OUT} = ca. 0V$)	ON	OFF	Open
Over-temperature	ON	OFF	Open
No input power	OFF	OFF	Open

The DC-ok LED and the DC-ok contact functions are synchronized

13. TERMINALS AND WIRING

Type	Bi-stable, quick-connect spring clamp terminals. IP20 Finger safe construction. Suitable for field- and factory installation. Shipped in open position.
Solid wire	0.5-6mm ²
Stranded wire	0.5-4mm ²
American wire gauge	20-10 AWG
Ferrules	Allowed, but not required
Wire stripping length	10mm / 0.4inch
Pull-out force	10AWG:80N, 12AWG:60N, 14AWG:50N, 16AWG:40N (according to UL486E)

Fig. 13-1 Connecting a wire

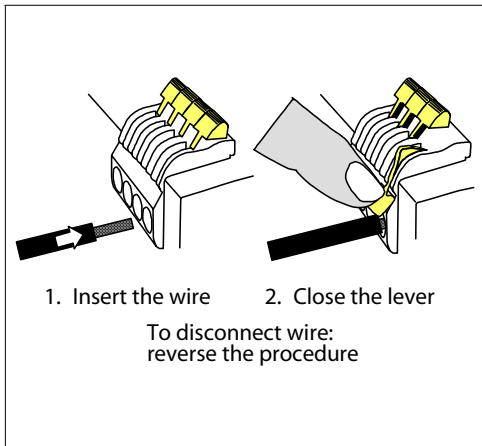

Instructions:

- Use appropriate copper cables that are designed for an operating temperature of:
 Input: 60°C for ambient up to 45°C and 75°C for ambient up to 60°C minimum.
 Output: 75°C for ambient up to 40°C and 95°C for ambient up to 60°C minimum.
- Follow local and national installation codes and installation regulations!
- Ensure that all strands of a stranded wire enter the terminal connection!
- Up to two stranded wires with the same cross section are permitted in one connection point (except PE wire).
- Do not use the unit without PE connection.

14. RELIABILITY

	600Vdc	
Lifetime expectancy	min.	42 000h 40°C, 24V, 20A
	min.	77 500h 40°C, 24V, 10A
	min.	119 000h 25°C, 24V, 20A
MTBF SN 29500, IEC 61709	t.b.d.	40°C, 24V, 20A
	t.b.d.	25°C, 24V, 20A
MTBF MIL HDBK 217F	t.b.d.	40°C, 24V, 20A, Ground Benign GB40
	t.b.d.	25°C, 24V, 20A, Ground Benign GB25

The Lifetime expectancy shown in the table above indicates the operating hours (service life) and is determined by the lifetime expectancy of the built-in electrolytic capacitors.

Lifetime expectancy is specified in operational hours and is calculated according to the capacitor's manufacturer specification. The prediction model allows a calculation of up to 15 years from date of shipment.

MTBF stands for Mean Time Between Failure, which is calculated according to statistical device failures, and indicates reliability of a device. It is the statistical representation of the likelihood of a unit to fail and does not necessarily represent the life of a product.

15. EMC

The power supply is suitable for applications in industrial environments without any restrictions. The CE mark is in conformance with EMC guideline 89/336/EEC and 93/68/EEC and the low-voltage directive (LVD) 73/23/EEC. A detailed EMC Report is available upon request

EMC Immunity	EN 61000-6-1, EN 61000-6-2, EN-61800-3	Generic and product standards		
Electrostatic discharge	EN 61000-4-2	Contact discharge	8kV	Criterion A
		Air discharge	15kV	Criterion A
Electromagnetic RF field	EN 6100 0-4-3	80MHz-1GHz	10V/m	Criterion A
Fast transients (Burst)	EN 61000-4-4	Input lines	2kV	Criterion A
		Output lines	2kV	Criterion A
Surge voltage on input	EN 61000-4-5	+ → -	1000V	Criterion A
Surge voltage on input	EN 61000-4-5	+ → PE, - → PE	4kV	Criterion A
Surge voltage on output	EN 61000-4-5	+ → -	500V	Criterion A
		+ / - → PE	500V	Criterion A
Conducted disturbance	EN 61000-4-6	0.15-80MHz	10V	Criterion A

Criteria:

A: Power supply shows normal operation behavior within the defined limits.

EMC Emission	EN 61000-6-4, EN-61800-3	Generic and product standards	
Conducted emission	EN 55011, EN 55022	N/A	*)
Radiated emission	EN 55011, EN 55022	Class A	

*) There are no mandatory requirements in the generic standard EN 61000-6-4 for conducted emission on DC lines (input and output). For the assessment of the conducted emission, the input filter of the frequency converter or servo amplifier need to be taken into account.

Switching Frequencies The power supply has three converters with three different switching frequencies included. One is nearly constant. The other two are input voltage and load dependent.

Switching frequency 1	100kHz	Nearly constant
Switching frequency 2	30kHz to 90kHz	Input voltage and load dependent
Switching frequency 3	17kHz to 120kHz	Input voltage and load dependent

16. ENVIRONMENT

Operational temperature	-25°C to +70°C (-13°F to 158°F)	Reduce output power above +60°C
Output de-rating	12W/°C	60-70°C (140°F to 158°F), see Fig. 16-1
Storage temperature	-40 to +85°C (-40°F to 185°F)	Storage and transportation
Humidity	5 to 95% r.H.	IEC 60068-2-30 Do not energize while condensation is present
Vibration sinusoidal	2-17.8Hz: ±1.6mm; 17.8-500Hz: 2g 2 hours / axis	IEC 60068-2-6
Vibration random	0.5m ² (s ³) 2 hours / axis	IEC 60068-2-64
Shock	30g 6ms, 20g 11ms 3 bumps / direction, 18 bumps in total	IEC 60068-2-27
Altitude	0 to 6000m (0 to 20 000ft)	Reduce output power or ambient temperature above 2000m sea level.
Output de-rating (for altitude)	30W/1000m or 5°C/1000m	above 2000m, see Fig. 16-2
Over-voltage category	III II	EN 50178, altitudes up to 2000m Altitudes from 2000m to 6000m
Degree of pollution	2	EN 50178, non conductive

Fig. 16-1 Output current vs. ambient temp.,

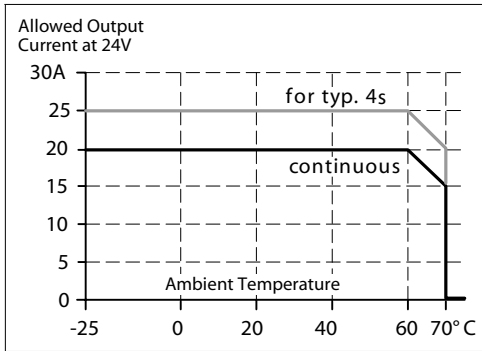
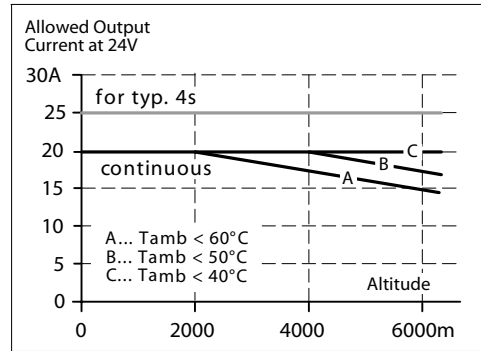

Fig. 16-2 Output current vs. altitude



The ambient temperature is defined as the air temperature 2cm below the unit.

17. PROTECTION FEATURES

Output protection	Electronically	protected against overload, no load and short circuits *)
Output over-voltage protection	typ. 32Vdc max. 35Vdc	In case of an internal power supply fault, a redundant circuit limits the maximum output voltage. The output shuts-down and automatically attempts to restart.
Degree of protection	IP 20	EN/IEC 60529
Penetration protection	> 3.5mm	e.g. screws, small parts
Over-temperature protection	yes	Output shut-down with automatic restart
Input transient protection	MOV (Metal Oxide	Varistor) and active transient filter
Internal input fuse	5A, midget size fast acting type 2 times (+ line and - line)	The unit is equipped with two internal input fuses which protect the unit against internal short circuits and ground faults. The fuses are not user accessible. A tripping of an internal fuse is caused by an internal fault.

*) An audible noise may be heard during a no load, overload or short circuit event.

18. SAFETY

Input / output separation	SELV PELV double or reinforced insulation	IEC/EN 60204-1 EN 60204-1, EN 50178, IEC 60364-4-41
Class of protection	I	PE (Protective Earth) connection required
Isolation resistance	> 5MΩ	Input to output, 500Vdc
PE resistance	< 0.10Ω	Between housing and PE terminal
Touch current (leakage current)	The leakage current which is produced by the power supply itself depends on the input voltage ripple and need to be investigated in the final application. For a smooth DC input voltage, the produced leakage current is less than 100µA.	

19. DIELECTRIC STRENGTH

Fig. 19-1 Dielectric strength

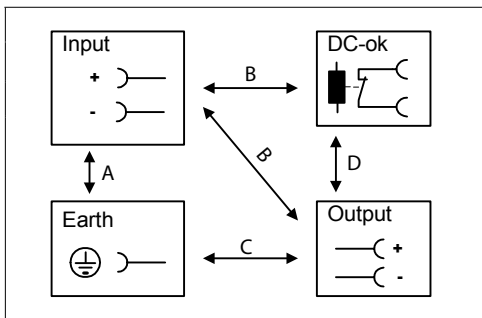

		A	B	C	D
Type test	60s	2500Vac	3000Vac	500Vac	500Vac
Factory test	5s	2500Vac	2500Vac	500Vac	500Vac
Field test	5s	2000Vac	2000Vac	500Vac	500Vac

Type tests and factory tests:
Conducted by the manufacturer. Do not repeat test in field!
Rules for field test:
Use appropriate test equipment which applies the voltage with a slow ramp! Connect L1, L2 and L3 together as well as all output poles.

The output voltage is floating and has no ohmic connection to ground.

To fulfill the PELV requirements according to EN60204-1 paragraph 6.4.1, PULS recommend that either the + pole or the - pole shall be connected to the protective earth system. This helps to avoid situations in which a load starts unexpectedly or cannot be switched off when an unnoticed ground fault occurs.

20. APPROVALS

UL 508
pending



LISTED E198865
Industrial Control Equipment

21. FULFILLED STANDARDS

EN 61558-2-17	Safety of Power Transformers
EN/IEC 60204-1	Safety of Electrical Equipment of Machines
EN/IEC 61131-2	Programmable Controllers
EN 50178, IEC 62103	Electronic Equipment for Use in Power Installations
EN 61800-5	Adjustable speed electrical power drive systems, Safety requirements

22. USED SUBSTANCES

The unit does not release any silicone and is suitable for the use in paint shops.

Electrolytic capacitors included in this unit do not use electrolytes such as Quaternary Ammonium Salt Systems.

Plastic housings and other molded plastic materials are free of halogens, wires and cables are not PVC insulated.

The materials used in our production process do not include the following toxic chemicals:

Polychlorinated Biphenyl (PCB), Polychlorinated Biphenyl (PCB), Pentachlorophenol (PCP), Polychlorinated naphthalene (PCN), Polybrominated Biphenyl (PBB), Polybrominated Biphenyl Oxide (PBO), Polybrominated Diphenyl Ether (PBDE), Polychlorinated Diphenyl Ether (PCDE), Polybrominated Diphenyl Oxide (PBDO), Cadmium, Asbestos, Mercury, Silica

23. P HYSICAL DIMENSIONS AND W EIGHT

Weight	890g / 1.96lb
DIN-Rail	Use 35mm DIN-rails according to EN 60715 or EN 50022 with a height of 7.5 or 15mm. The DIN-rail height must be added to the depth (127mm) to calculate the total required installation depth.

CAD files with mechanical data ca

Fig. 23-1 Front view

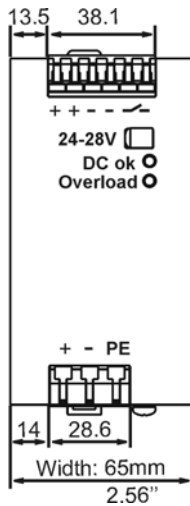
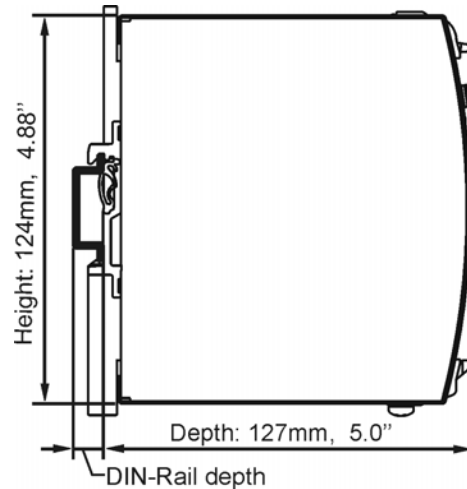

Fig. 23-2 Side view



24. I NSTALLATION AND O PERATION I NSTRUCTIONS

Mounting and installation:

Output terminal must be located on top and input terminal on the bottom. For other orientations see section 26.10. An appropriate electrical and fire end-product enclosure should be considered in the end use application.

Cooling:

Convection cooled, no forced cooling required. Do not cover ventilation grill (e.g. cable conduits) by more than 30%!

Installation clearances:

40mm on top, 20mm on the bottom, 5mm on the left and right side are recommended when loaded permanently with full power. If the adjacent device is a heat source, 15mm clearance is recommended.

Risk of electrical shock, fire, personal injury or death!

Do not use the unit without proper earth connection (Protective Earth). Use the pin on the terminal block for earth connection and not one of the screws on the housing.

Turn power off before working on the power supply. Protect against inadvertent re-powering.

Make sure the wiring is correct by following all local and national codes.

Do not open, modify or repair the unit.

Use caution to prevent any foreign objects from entering into the housing.

Do not use in wet locations or in areas where moisture or condensation can be expected.

Service parts:

The unit does not contain any serviceable parts. The tripping of an internal fuse is caused by an internal fault. If damage or malfunctioning should occur, immediately turn power off and send the unit back to the factory for inspection!

25. ACCESSORIES

ZM1.WALL Wall mounting bracket

This bracket is used to mount Dimension units onto a flat surface without utilizing a DIN-Rail. The two aluminum brackets and the black plastic slide of the unit have to be removed, so that the two steel brackets can be mounted.

Fig. 25-1 ZM1.WALL Wall Mounting Bracket

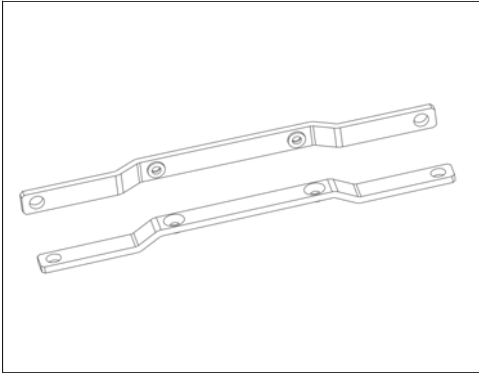
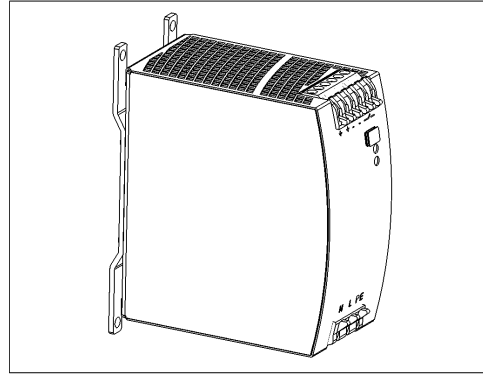

Fig. 25-2 Assembled Wall Mounting Bracket



ZM14.SIDE Side mounting bracket

This bracket is used to mount specific Dimension units sideways with or without utilizing a DIN-Rail. The two aluminum brackets and the black plastic slide of the unit have to be detached, so that the steel brackets can be mounted.

For sideways DIN-rail mounting, the removed aluminum brackets and the black plastic slide need to be mounted on the steel bracket.

Fig. 25-3 ZM14.SIDE Side Mounting Bracket
Panel Mount

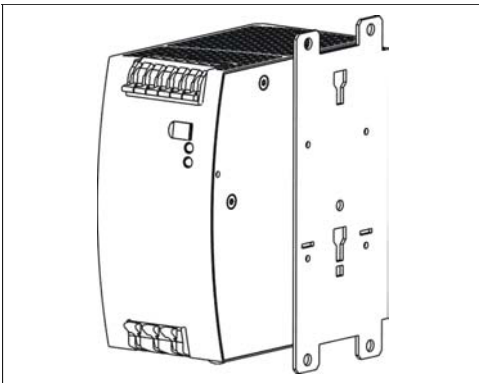
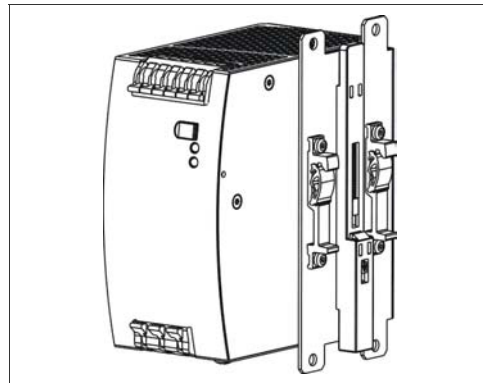

Fig. 25-4 ZM14.SIDE Side Mounting Bracket
DIN-Rail Mount



26. APPLICATION NOTES

26.1. REPETITIVE PULSE LOADING

Typically, a load current is not constant as it varies over time. For pulse load compatibility the following rules must be met:

- The pulse power demand must be below 125% of the nominal power.
- The duration of the pulse power must be shorter than the allowed Bonus Time. (see output section)
- The average (R.M.S.) output current must be below the specified continuous output current.
If the R.M.S. current is higher, the unit will respond with a thermal shut-down after a period of time. Use the "Max. Duty Cycle Curve" (Fig. 26-2) to check if the average output current is below the nominal current.
- The duty cycle must be below 0.75.
- For altitudes higher than 2000m reduce the pulse loading (15W/1000m) or the ambient temperature (5°C/1000m)

Fig. 26-1 Repetitive pulse loads, definitions

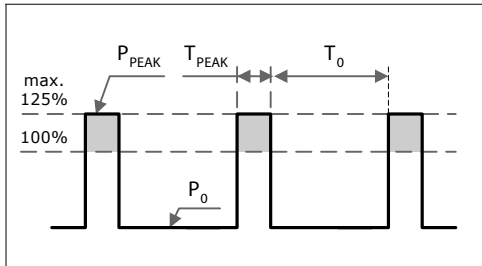

- P_0 Base load (W)
- P_{PEAK} Pulse load (above 100%)
- T_0 Duration between pulses (s)
- T_{PEAK} Pulse duration (s)

Fig. 26-2 Max. Duty Cycle Curve

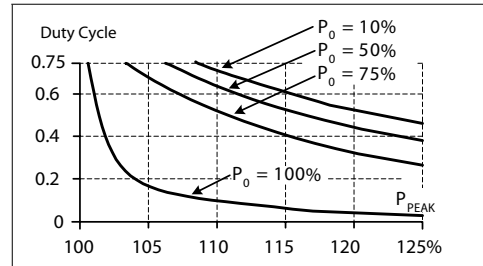

$$\text{Duty Cycle} = \frac{T_{\text{peak}}}{T_{\text{peak}} + T_0}$$

$$T_0 = \frac{T_{\text{peak}} - (\text{Duty Cycle} \times T_{\text{peak}})}{\text{Duty Cycle}}$$

Utilizing the Max. Duty Cycle Curve:

Example to determine the repetition rate of pulses without dipping of the output voltage:

Parameters of application:

Pulse length of $T_{PEAK} = 1s$

Steady state load $P_0 = 120W$
(= 50% of I_{RATED})

Peak load $P_{PEAK} = 600W$
(= 125% of I_{RATED})

Determining the repetition rate:

- make a vertical line at $P_{PEAK} = 125\%$
- make a horizontal line where the vertical line crosses the $P_0 = 50\%$ curve
- Read the Max. Duty Cycle from the Duty Cycle-axis (= 0.37)
- Calculate the min. pause (base load) length T_0 :

$$T_0 = \frac{T_{\text{peak}} - (\text{Duty Cycle} \times T_{\text{peak}})}{\text{Duty Cycle}} = \frac{1s - (0.37 \times 1s)}{0.37} = \underline{1.7s}$$
- Pulse length = 1s, min. pause length = 1.7s
- Max. repetition rate = pulse length + pause length = 2.7s

More examples for pulse load compatibility:

P_{PEAK}	P_0	T_{PEAK}	T_0
600W	480W	1s	>25s
600W	0W	1s	>1.3s
540W	240W	1s	>0,75s

P_{PEAK}	P_0	T_{PEAK}	T_0
600W	240W	0.1s	>0.16s
600W	240W	1s	>1.6s
600W	240W	3s	>4.9s

26.2. BACK-FEEDING LOADS

Loads such as decelerating motors and inductors can feed voltage back to the power supply. This feature is also called return voltage immunity or resistance against Back- E.M.F. (Electro Magnetic Force).

This power supply is resistant and does not show adverse effects when a load feeds back voltage to the power supply. It does not matter, whether the power supply is on or off.

The maximum allowed feed back voltage is 34Vdc. The absorbing energy can be calculated according to the built-in large sized output capacitor which is specified in chapter 7.

CHARGING OF BATTERIES

The power supply can be used to charge lead-acid or maintenance free batteries. (Two 12V batteries in series)

Instructions for charging batteries:

- a) Set output voltage (measured at the battery) very precisely to the end-of-charge voltage.

End-of-charge voltage	27.8V	27.5V	27.15V	26.8V
Battery temperature	10°C	20°C	30°C	40°C

- b) Use a 25A circuit breaker (or blocking diode) between the power supply and the battery.
- c) Ensure that the output current of the power supply is below the allowed charging current of the battery.
- d) Use only matched batteries when putting 12V types in series.
- e) The return current to the power supply is typ. 16mA at 25Vdc when the power supply is switched off (except in case a blocking diode is utilized).

26.3. OUTPUT CIRCUIT BREAKERS

Standard miniature circuit breakers (MCBs or UL1077 circuit breakers) can be used for branch protection. Ensure that the MCB is rated for DC voltage, too. The following tests show which circuit breakers the power supply typically trips. Circuit breakers have huge tolerances in their tripping behavior. Therefore, these typical tests can only be used as a recommendation or for comparing two different power supplies. Furthermore, the loop impedance has a major influence on whether a breaker trips or not. Two tests were performed, representing typical situations:

Test 1: Short circuit with S1 on the power supply end of the cable (loop impedance approx. 20mOhm)

Fig. 26-3 Branch protectors, test circuit 1

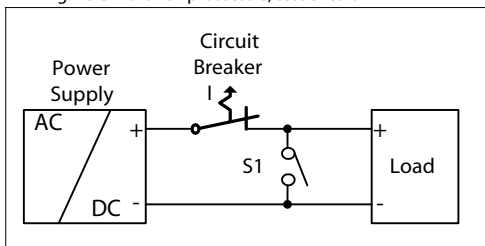

Parameters:

Input voltage: 600Vdc, load current: 0A
 Tripping time shorter than 5s.

The following circuit breaker tripped during the test:

- A- or Z- Characteristic: equal or smaller 10A *)
- B- Characteristic: equal or smaller 10A *)
- C- Characteristic: equal or smaller 10A *)

Test 2: Short circuit with S1 on the load end (additional impedance included; represents longer load wire length).

Fig. 26-4 Branch protectors, test circuit 2

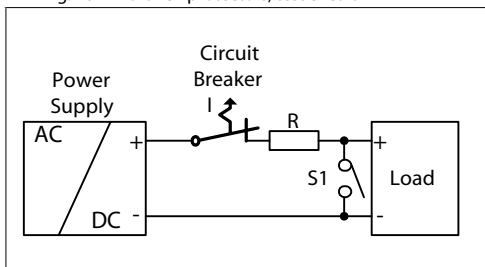

Parameters:

Input voltage: 600Vdc, load current: 0A
 Tripping time shorter than 5s.

The following circuit breaker tripped during the test:

- A- or Z- Characteristic: $\leq 10A$ and $R < 120m\Omega$ *)
- B- Characteristic: $\leq 10A$ and $R < 120m\Omega$ *)
- C- Characteristic: $\leq 8A$ and $R \leq 150m\Omega$ *)

What does this resistance mean in wire length?

	0.5mm ²	0.7mm ²	1.0mm ²	1.5mm ²	2.5mm ²	4.0mm ²
120mOhm	3.3m	4.7m	6.7m	10.0m	16.7m	26.7m
150mOhm	4.2m	5.9m	8.4m	12.5m	20.9m	33.4m

*) A list of the circuit breakers under test is available on request.

Example:

Which wire gauge must be used at a length of 15m before a B-Characteristic circuit breaker with 10A will trip?

Answer: A 10A B-Characteristic circuit breaker requires a loop impedance of less than 120mOhm based on the test results. The wire length table shows that a length of 16.7m wire with a cross section of 2.5mm² is measured at 120mOhm. A wire not smaller than 2.5mm² shall be used.

26.4. PARALLEL USE TO INCREASE OUTPUT POWER

Power supplies can be paralleled to increase the output power.

Fig. 26-5 Schematic for parallel operation

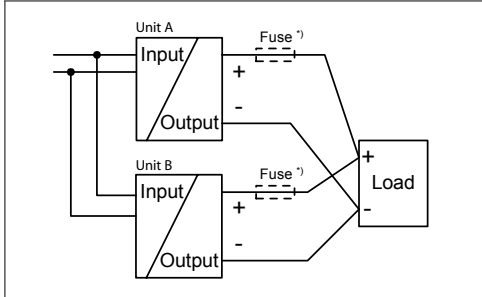

Instructions for parallel use:

- a) Use only power supplies from the same series (Q-Series).
- b) Adjust the output voltages of all power supplies to approximately the same value ($\pm 500\text{mV}$). Otherwise, the DC-ok signal might not work properly.
- c) A fuse (or diode) on the output is only required if more than three units are connected in parallel.
- d) Keep an installation clearance of 15mm (left / right) between two power supplies and avoid installing the power supplies on top of each other.

26.5. PARALLEL USE FOR REDUNDANCY

Power supplies can be paralleled for redundancy to gain a higher system availability. Redundant systems require a certain amount of extra power to support the load in case one power supply unit fails. The simplest way is to put two Q-Series power supplies in parallel. This is called a 1+1 redundancy. In case one power supply unit fails, the other one is automatically able to support the load current without any interruption. Redundant systems for a higher power demand are usually built in a N+1 method. E.g. Five power supplies, each rated for 10A are paralleled to build a 40A redundant system.

Please note: This simple way to build a redundant system does not cover failures such as an internal short circuit on the secondary side of the power supply. In such cases, the defect unit becomes a load for the other power supplies and the output voltage can not be maintained any more. This can only be avoided by utilizing decoupling diodes which are included in the decoupling module YR2.DIODE. (One module per power supply)

Recommendations for building redundant power systems:

- a) Use separate input fuses for each power supply.
- b) Monitor the individual power supply units. A DC-ok LED and a DC-ok contact is already included in the units. This feature reports a faulty unit.
- c) When possible, connect each power supply to different phases or circuits.
- d) It is desirable to set the output voltages of all power supplies to the same value to avoid a false DC-ok signal.

26.6. DAISY CHAINING OF OUTPUTS

Daisy chaining (jumping from one power supply output terminal to the next) is allowed as long as the maximum current through one terminal pin does not exceed 25A. If the current is higher, use a separate distribution terminal block.

Fig. 26-6 Daisy chaining of outputs

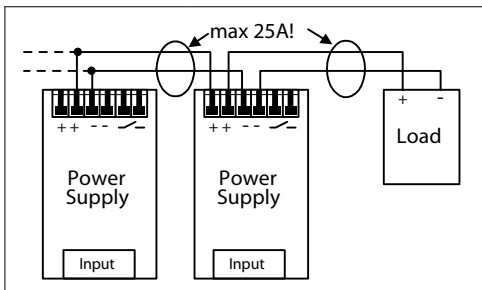
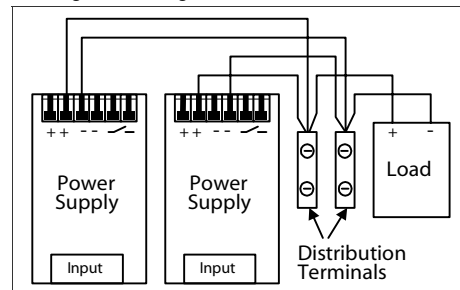

Fig. 26-7 Using distribution terminals



26.7. S ERIES O P E R A T I O N

The power supply can be put in series to increase the output voltage.

Fig. 26-8 Schematic for series operation

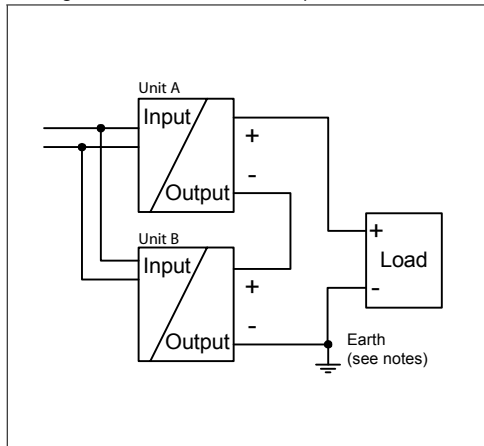

Instructions for use in series:

- It is possible to connect as many units in series as needed, providing the sum of the output voltage does not exceed 150Vdc.
- Voltages with a potential above 60Vdc are not considered SELV any longer and can be dangerous. Such voltages must be installed with a protection against touching.
- For serial operation use power supplies of the same type.
- Earthing of the output is required when the sum of the output voltage is above 60Vdc.
- Keep an installation clearance of 15mm (left/right) between two power supplies and avoid installing the power supplies on top of each other.

Note: Avoid return voltage (e.g. from a decelerating motor or battery) which is applied to the output terminals.

26.8. I N D U C T I V E A N D C A P A C I T I V E L O A D S

The unit is designed to supply any kind of load, including unlimited capacitive and inductive loads.

26.9. U S E I N A T I G H T L Y S E A L E D E N C L O S U R E

When the power supply is installed in a tightly sealed enclosure, the temperature inside the enclosure will be higher than the outside. The inside temperature defines the ambient temperature for the power supply.

Results from such an installation:

Power supply is placed in the middle of the box, no other heat producing equipment inside the box

Enclosure:	Rittal Typ IP66 Box PK 9519 100, plastic, 180x180x165mm
Load:	24V, 16A (=80% of the rated load); load is placed outside the box
Input:	600Vdc
Temperature inside enclosure:	54.9°C (in the middle of the right side of the power supply with a distance of 2cm)
Temperature outside enclosure:	22.6°C
Temperature rise:	32.3K

26.10.M MOUNTING ORIENTATIONS

Mounting orientations other than input terminals on the bottom and output on the top requires a reduction in continuous output power or a limitation in the maximum allowed ambient temperature. The amount of reduction influences the lifetime expectancy of the power supply. Therefore, two different derating curves for continuous operation can be found below:

Curve A1 Recommended output current.

Curve A2 Max allowed output current (results approx. in half the lifetime expectancy of A1).

Fig. 27-12
Mounting
Orientation A
Standard
Orientation

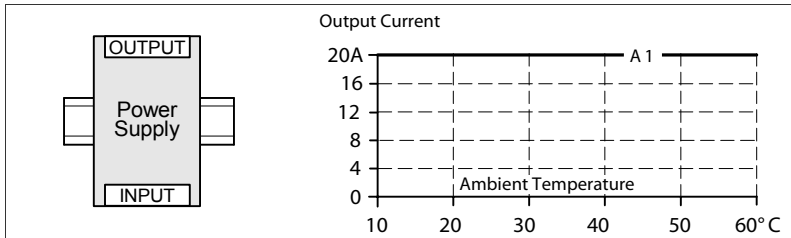

Fig. 27-13
Mounting
Orientation B
(Upside down)

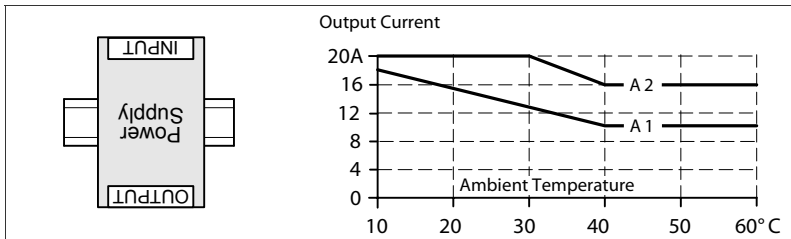

Fig. 27-14
Mounting
Orientation C
(Table-top
mounting)

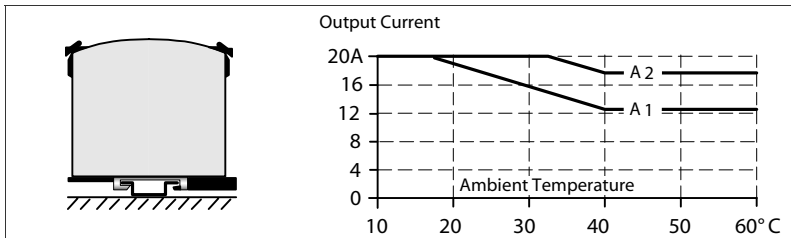

Fig. 27-15
Mounting
Orientation D
(Horizontal cw)

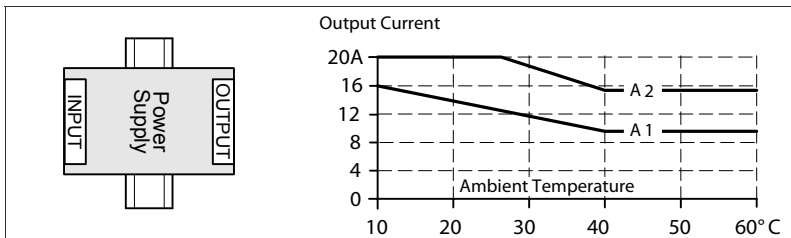

Fig. 27-16
Mounting
Orientation E
(Horizontal ccw)

