

1. GENERAL DESCRIPTION

BRACKET FOR FLAT MOUNTING

This accessory is used to mount Dimension power supplies and other Dimension units sideways to reduce the installation depth. The two aluminum brackets and the black plastic slide must be removed from the units, to allow mounting of the zinc-plated steel bracket.

Two mounting options are possible:

- ? Panel Mount
- ? 35mm DIN-Rail Mount

2. DIMENSIONS AND INSTALLATION DATA

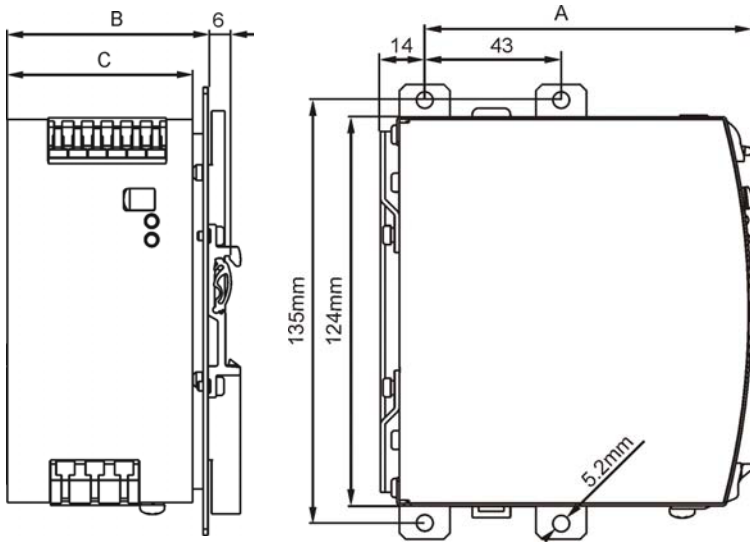

The drawings on the left show the bracket for DIN-rail mounting. The total installation depth is the B dimension plus 6mm plus the height of the DIN-Rail. In case the unit is panel mounted, the B dimension shows the required installation depth.

Use	Bracket	A	B	C	Length	Width	Height	Bracket Weight
QS3.XXX	ZM11.SIDE	89mm	38mm	32mm	145mm	65mm	37mm	140g
QS5.XXX	ZM12.SIDE	104mm	46mm	40mm	145mm	65mm	44mm	160g
QS10.XXX	ZM13.SIDE	104mm	66mm	60mm	145mm	65mm	63mm	180g
QT20.XXX	ZM14.SIDE	124mm	71mm	65mm	145mm	65mm	76mm	195g
YR2.DIODE	ZM11.SIDE	89mm	38mm	32mm	145mm	65mm	37mm	140g
UF20.XXX	ZM14.SIDE	89mm	79mm	64mm	145mm	65mm	76mm	195g
CS5.XXX	ZM11.SIDE	104mm	38mm	32mm	145mm	65mm	37mm	140g
CS10.XXX	ZM13.SIDE	104mm	66mm	60mm	145mm	65mm	63mm	180g

3. ASSEMBLY AND MOUNTING INSTRUCTIONS

Fig. 3-1 Detaching DIN-Rail brackets

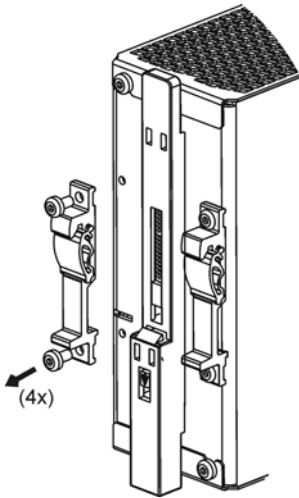

Detach the two aluminium brackets by removing the four screws with a Torx screwdriver (Torx 10). Save the screws for step 3.

Fig. 3-2 Detach slide

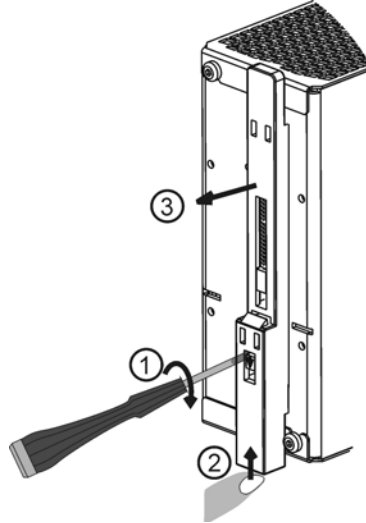

Remove the plastic lock mechanism by using a flat-blade screwdriver to move the lock downwards while at the same time push the plastic slide upwards. Detach the plastic slide.

Fig. 3-3 Mounting steel bracket

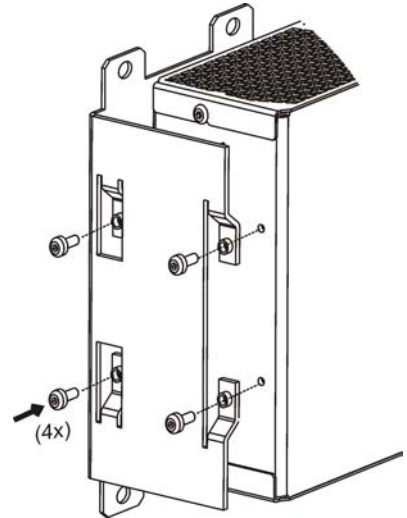

Mount the steel brackets with the same screws from the DIN-Rail brackets using caution not to over-tighten the screws! Recommended tightening torque is 0.6Nm. (5.3lb.in).

Two mounting options:

- Panel Mount
- DIN-Rail Mount

Preparation for DIN-Rail mounting:

Install the two aluminium brackets and the plastic slide (detached from the unit before) onto the side mounting plant with the additional screws provided.

Fig. 3-4 Panel Mount

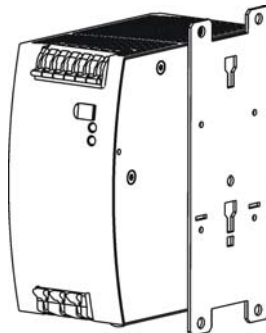
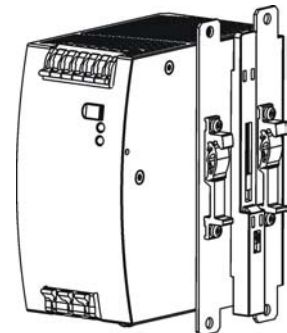

Fig. 3-5 DIN-Rail Mount



4. ORDER NUMBERS

Accessory	ZM11.SIDE	Side-mounting Bracket Kit 145x65x37mm
	ZM12.SIDE	Side-mounting Bracket Kit 145x65x44mm
	ZM13.SIDE	Side-mounting Bracket Kit 145x65x63mm
	ZM14.SIDE	Side-mounting Bracket Kit 145x65x76mm