





X-TIO-B

Instruction Manual

IMS01N03-E3

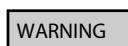
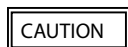
Thank you for purchasing this RKC product. In order to achieve maximum performance and ensure proper operation of your new instrument, carefully read all the instructions in this manual. Please place this manual in a convenient location for easy reference.

SYMBOLS

-  : This mark indicates precautions that must be taken if there is danger of electric shock, fire, etc., which could result in loss of life or injury.
-  : This mark indicates that if these precautions and operating procedures are not taken, damage to the instrument may result.
-  : This mark indicates that all precautions should be taken for safe usage.
-  : This mark indicates important information on installation, handling and operating procedures.
-  : This mark indicates supplemental information on installation, handling and operating procedures.
-  : This mark indicates where additional information may be located.



WARNING

- An external protection device must be installed if failure of this instrument could result in damage to the instrument, equipment or injury to personnel.
- All wiring must be completed before power is turned on to prevent electric shock, fire or damage to instrument and equipment.
- This instrument must be used in accordance with the specifications to prevent fire or damage to instrument and equipment.
- This instrument is not intended for use in locations subject to flammable or explosive gases.
- Do not touch high-voltage connections such as power supply terminals, etc. to avoid electric shock.
- RKC is not responsible if this instrument is repaired, modified or disassembled by other than factory-approved personnel. Malfunction can occur and warranty is void under these conditions.

CAUTION

- This is a Class A instrument. In a domestic environment, this instrument may cause radio interference, in which case the user may be required to take adequate measures.

- This instrument is protected from electric shock by reinforced insulation. Provide reinforced insulation between the wire for the input signal and the wires for instrument power supply, source of power and loads.
- Be sure to provide an appropriate surge control circuit respectively for the following:
 - If input/output or signal lines within the building are longer than 30 meters.
 - If input/output or signal lines leave the building, regardless the length.
- This instrument is designed for installation in an enclosed instrumentation panel. All high-voltage connections such as power supply terminals must be enclosed in the instrumentation panel to avoid electric shock by operating personnel.
- All precautions described in this manual should be taken to avoid damage to the instrument or equipment.
- All wiring must be in accordance with local codes and regulations.
- All wiring must be completed before power is turned on to prevent electric shock, instrument failure, or incorrect action.

The power must be turned off before repairing work for input break and output failure including replacement of sensor, contactor or SSR, and all wiring must be completed before power is turned on again.
- To prevent instrument damage or failure, protect the power line and the input/output lines from high currents with a protection device such as fuse, circuit breaker, etc.
- Prevent metal fragments or lead wire scraps from falling inside instrument case to avoid electric shock, fire or malfunction.
- Tighten each terminal screw to the specified torque found in the manual to avoid electric shock, fire or malfunction.
- For proper operation of this instrument, provide adequate ventilation for heat dissipation.
- Do not connect wires to unused terminals as this will interfere with proper operation of the instrument.
- Turn off the power supply before cleaning the instrument.
- Do not use a volatile solvent such as paint thinner to clean the instrument. Deformation or discoloration will occur. Use a soft, dry cloth to remove stains from the instrument.
- To avoid damage to instrument display, do not rub with an abrasive material or push front panel with a hard object.
- Do not connect modular connectors to telephone line.

NOTICE

- This manual assumes that the reader has a fundamental knowledge of the principles of electricity, process control, computer technology and communications.
- The figures, diagrams and numeric values used in this manual are only for purpose of illustration.
- RKC is not responsible for any damage or injury that is caused as a result of using this instrument, instrument failure or indirect damage.
- Periodic maintenance is required for safe and proper operation of this instrument. Some components have a limited service life, or characteristics that change over time.
- Every effort has been made to ensure accuracy of all information contained herein. RKC makes no warranty expressed or implied, with respect to the accuracy of the information. The information in this manual is subject to change without prior notice.
- No portion of this document may be reprinted, modified, copied, transmitted, digitized, stored, processed or retrieved through any mechanical, electronic, optical or other means without prior written approval from RKC.

1. OUTLINE

One temperature control (TIO) module [extension type] enables temperature control corresponding to two channels. As the temperature control (TIO) module [extension type] is not provided with terminals for power supply and host communication, it is always used together with the module (temperature control module [basic type] X-TIO-A, etc.) with terminals for power supply and host communication. The temperature control (TIO) module [extension type] can be connected with the temperature control (TIO) module [basic type], the temperature control (TIO) module for PLC communication, the digital input (DI) module and the digital output (DO) module.

 All data are set by communication. For details, see the **Module Type Controller SRX Communication Instruction Manual (IMS01N01-E□)**.

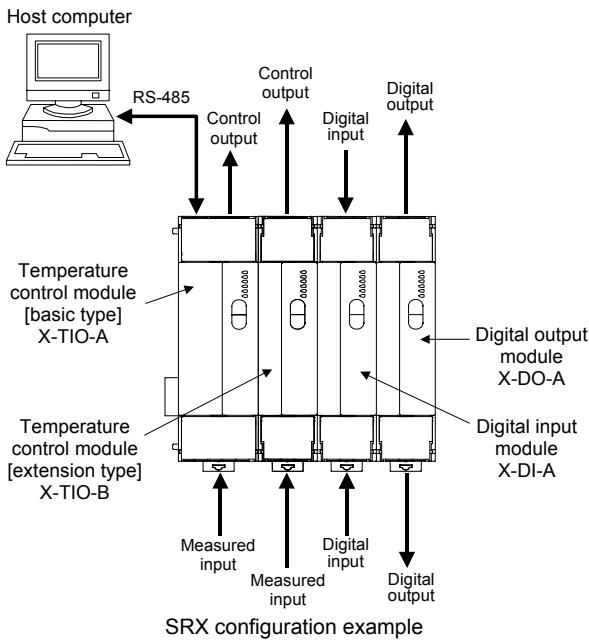

2. PRODUCT CHECK

Before using this product, check each of the following:

- Model code
- Check that all of the accessories delivered are complete.
- Check that there are no scratch or breakage in external appearance (case, front panel, or terminal, etc).

X-TIO-B- □ □ - □ □ * □ □ / Y
 (1) (2) (3) (4) (5) (6) (7)

(1) Type

B: Extension type (14 terminals)

(2) Input channel 1, (3) Input channel 2

- | | | | |
|------------------|---------------|---------|---------|
| K: TC K | J: TC J | T: TC T | S: TC S |
| R: TC R | A: TC PLII | N: TC N | E: TC E |
| W: TC W5Re/W26Re | B: TC B | | |
| D: RTD Pt100 | P: RTD JPt100 | | |
- | | | |
|------------------|-------------------|----------------|
| 1: 0 to 10 mV DC | 2: 0 to 100 mV DC | 3: 0 to 1 V DC |
| 4: 0 to 5 V DC | 5: 0 to 10 V DC | 6: 1 to 5 V DC |
| 7: 0 to 20 mA DC | 8: 4 to 20 mA DC | |

(4) Control output 1, (5) Control output 2

- | | | |
|-------------------------|-----------------------------------|----------------|
| M: Relay contact output | V: Voltage pulse output 0/12 V DC | |
| 4: 0 to 5 V DC | 5: 0 to 10 V DC | 6: 1 to 5 V DC |
| 7: 0 to 20 mA DC | 8: 4 to 20 mA DC | |

(6) CT1 input, (7) CT2 input

- N: None P: CTL-6-P-N S: CTL-12-S56-10L-N

■ Accessories
 Instruction Manual (IMS01N03-E3) 1

3. PARTS DESCRIPTION

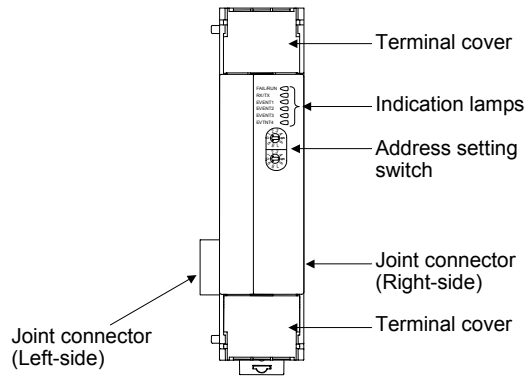

[Indication lamps]

- FAIL/RUN
 When normally: A green lamp turns on (RUN)
 When abnormally: A red lamp turns on (FAIL)
- RX/TX
 During data send and receive: A green lamp turns on
- EVENT 1 to 4
 Display various states by setting.
 During ON state: A green lamp turns on

Display contents

Event 1 state, Event 2 state, Comprehensive event state, Output state, Control state, Executing segment state, Time signal state

4. COMMUNICATION SETTING

Set communication setting before mounting and wiring of SRX.

4.1 Module Address Setting

Set an address of module. For this setting, use a small blade screwdriver.

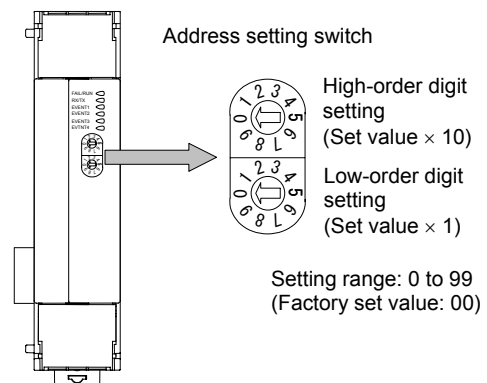

- For Modbus, the value obtained by adding "1" to the set address corresponds to the address used for the actual program.
- Set the module address such that it is different to the other addresses on the same line. Otherwise, problems or malfunction may result.

4.2 Protocol Selections and Communication Speed Setting

With the DIP switch which there is on the right side of module, select communication speed, data bit configuration, protocol and termination resistor of internal data bus.

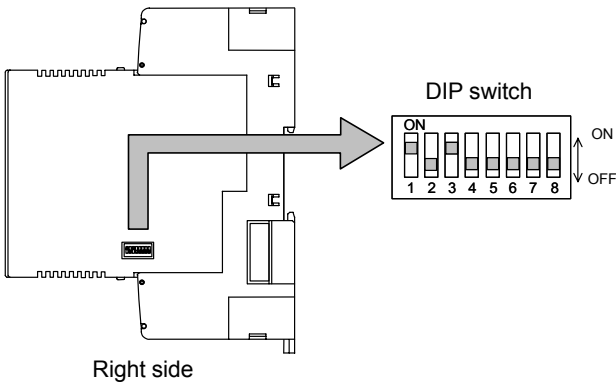

1	2	Communication speed
OFF	OFF	2400 bps
ON	OFF	9600 bps
OFF	ON	19200 bps
ON	ON	38400 bps

Factory set value: 9600 bps

3	4	5	Data bit configuration
OFF	OFF	OFF	Data 7-bit, without parity, Stop 1-bit *
OFF	OFF	ON	Data 7-bit, Even parity, Stop 1-bit *
OFF	ON	ON	Data 7-bit, Odd parity, Stop 1-bit *
ON	OFF	OFF	Data 8-bit, without parity, Stop 1-bit
ON	OFF	ON	Data 8-bit, Even parity, Stop 1-bit
ON	ON	ON	Data 8-bit, Odd parity, Stop 1-bit

* When the Modbus communication protocol selected, this setting becomes invalid.

Factory set value: Data 8-bit, without parity

6	Protocol selection
OFF	RKC communication
ON	Modbus

Factory set value: RKC communication

8	Internal data bus termination resistor setting
OFF	Termination resistor OFF
ON	Termination resistor ON

Factory set value: Termination resistor OFF



- **Switch No. 7: OFF fixed (Don't change this one)**
- **When two or more modules are connected on the same line for their use, set DIP switches corresponding to the switches, 1 to 6 on all of the modules to the same positions. In addition, always turn on the switch, 8 (with the internal bus termination resistance connected) in module of both ends.**
- **Be changed into communication time setting mode by using switch No. 4, 5 and 6.**



For communication time setting mode, see the **Module Type Controller SRX Communication Instruction Manual (IMS01N01-E□)**.

5. MOUNTING



WARNING

To prevent electric shock or instrument failure, always turn off the power before mounting or removing the instrument.

5.1 Mounting Cautions

- (1) This instrument is intended to be used under the following environmental conditions. (IEC61010-1)
[OVERVOLTAGE CATEGORY II, POLLUTION DEGREE 2]
- (2) Use this instrument within the following ambient temperature and ambient humidity.
 - Allowable ambient temperature: -10 to +50 °C
 - Allowable ambient humidity: 5 to 95 % RH (Absolute humidity: MAX. W. C 29 g/m³ dry air at 101.3 kPa)
- (3) Avoid the following when selecting the mounting location:
 - Rapid changes in ambient temperature, which may cause condensation.
 - Corrosive or inflammable gases.
 - Direct vibration or shock to the mainframe.
 - Water, oil, chemicals, vapor or steam splashes.
 - Excessive dust, salt or iron particles.
 - Excessive induction noise, static electricity, magnetic fields or noise.
 - Direct air flow from an air conditioner.
 - Exposure to direct sunlight.
 - Excessive heat accumulation.
- (4) Mounting consideration
 - Install the module 200 mm away from the main power line.
 - Ensure at least 50 mm space on top and bottom of the control unit for maintenance and environmental reasons.

5.2 Dimensions

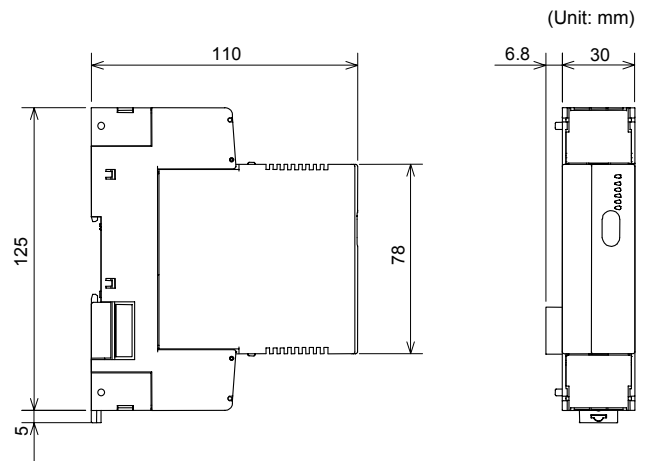

5.3 DIN rail Mounting

■ Mounting procedures

1. Pull down the mounting bracket at the bottom of the module (A). Attach the hooks on the top of the module to the DIN rail and push the lower section into place on the DIN rail (B).

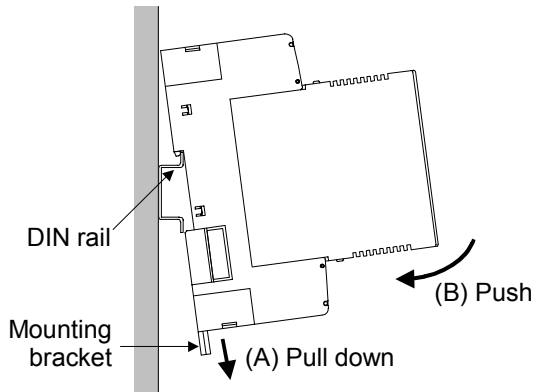

Fig. 1

2. Slide the mounting bracket up to secure the module to the DIN rail. (Fig. 2)

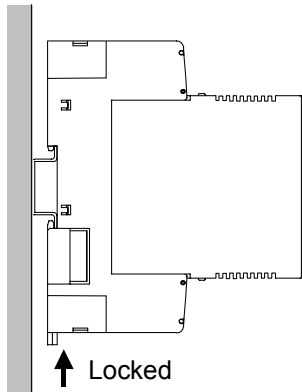
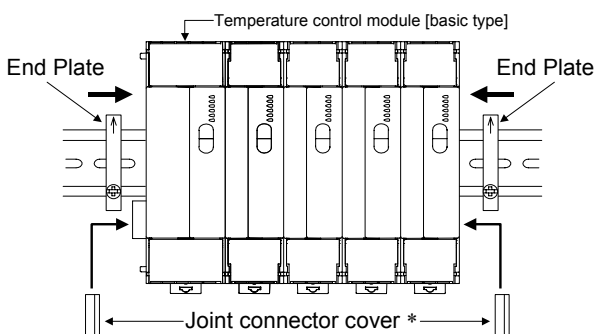

Fig. 2

■ End Plate mounting

Hold tight both ends of the modules joined together with the end plates attached to the temperature control module [basic type] and then fix the end plates with screws.



* For the conservation of the contact of connector, install a joint connector cover (be attached to the temperature control module [basic type]) in module of both ends.

■ Removing procedures

Pull down a mounting bracket with a blade screwdriver (A). Lift the module from bottom, and take it off (B).

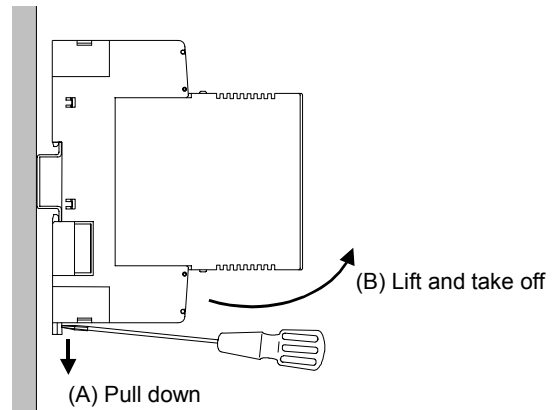

5.4 Panel Mounting

■ Mounting procedures

1. Pull down the mounting bracket (A) until locked and that a mounting hole appears.
2. Prepare one mounting bracket per module (B) sold separately (KSRX-55) and then insert it in the rear of the terminal board at top of the module until locked but a mounting hole does not disappear.
3. Mount each module directly on the panel with screws which are inserted in the mounting holes of the top and bottom mounting brackets.

Recommended tightening torque: 0.3 N·m (3 kgf·cm)



The customer needs to provide the M3 size screws. Select the screw length that matches the mounting panel.

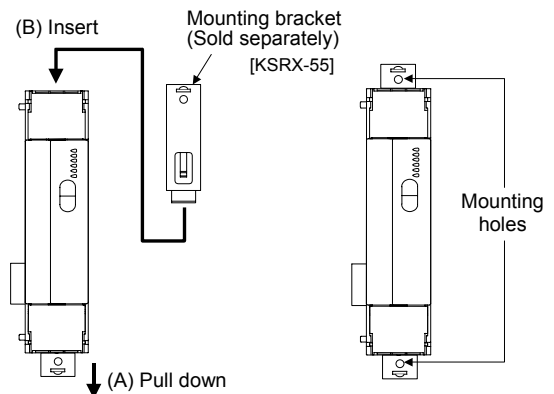

Mounting dimensions

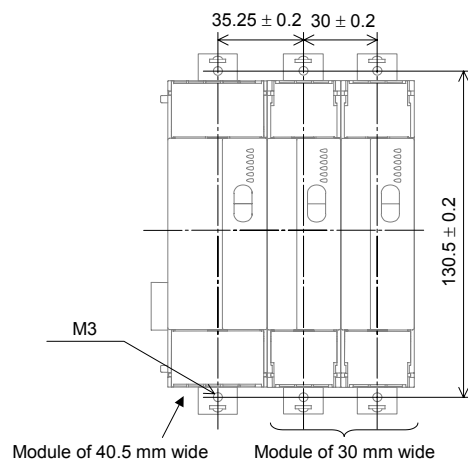

5.5 Jointing Each Module

Up to 31 SRXs consisting of the each modules can be jointed together. Joint these modules according to the following procedure.

■ Jointing procedure

1. Mount the modules on the DIN rail and then joint these modules together with the joint connector while sliding the relevant module.
2. Lift each of the joint tabs located at the top and bottom of the module and then insert it in the slot of the adjacent module to fix these two modules.

 For panel mounting, first joint each module and then mount it on the panel.

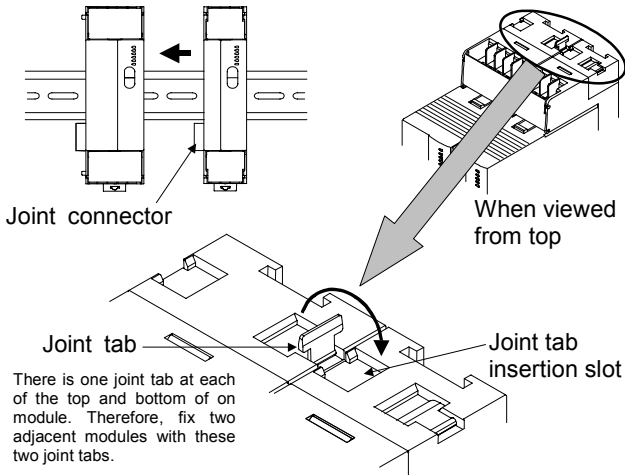

6.2 Terminal Configuration

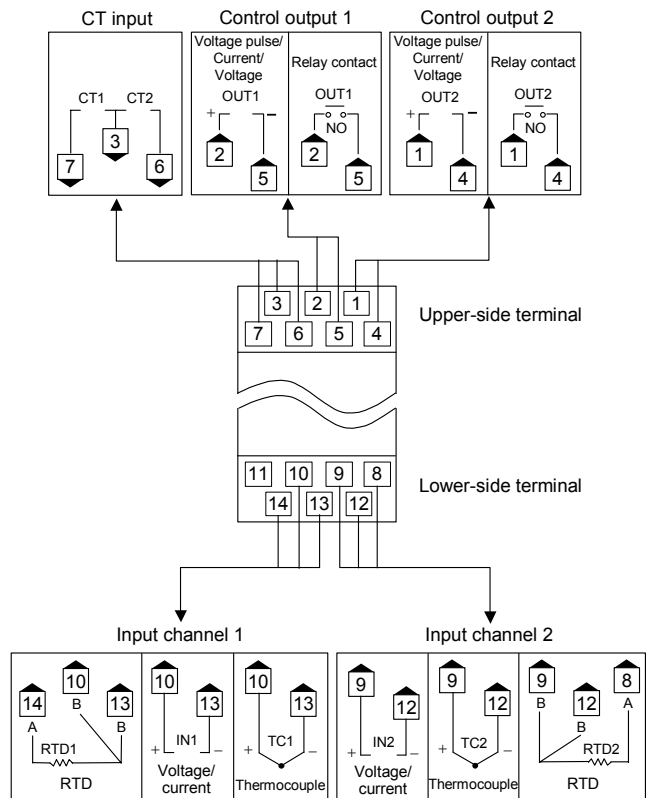

- 
- Terminal No. 11 is not used.
 - Input channel 2 can be used as remote setting input (only for voltage/current input). In this case, control output 2 and CT input 2 become unused.
 - Use the solderless terminal appropriate to the screw size (M3).

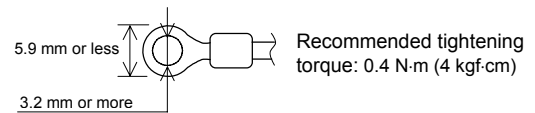

6. WIRING



To prevent electric shock or instrument failure, do not turn on the power until all the wiring is completed.

6.1 Wiring Cautions

- For thermocouple input, use the appropriate compensation wire.
- For RTD input, use low resistance lead wire with no difference in resistance between the three lead wires.
- To avoid noise induction, keep input signal wire away from instrument power line, load lines and power lines of other electric equipment.

7. SPECIFICATIONS

■ Inputs

Number of inputs:	2 points (Isolated between each channel)
Input type:	
• Thermocouple	K, J, T, S, R, E, B, N (JIS-C1602-1995) PLII (NBS) W5Re/W26Re (ASTM-E988-96)
• RTD:	Pt100 (JIS-C1604-1997) JPt100 (JIS-C1604-1989, Pt100 of JIS-C1604-1981)
• Voltage (low):	0 to 10 mV, 0 to 100 mV, 0 to 1 V
• Voltage (high):	0 to 5 V, 0 to 10 V, 1 to 5 V
• Current:	0 to 20 mA, 4 to 20 mA (Input impedance: 250 Ω)
Sampling cycle:	25 ms
PV bias:	-Input span to +Input span
CT input:	2 points 0.0 to 30.0 A (CTL-6P-N) or 0.0 to 100.0 A (CTL-12-S56-10L-N)

■ Outputs

Number of outputs: 2 points
(Isolated between input and output, and between output and power supply)

Output type:

- Relay contact: 250 V AC, 3 A (Resistive load)
1a contact
Electrical life 300,000 times or more
(Rated load)
- Voltage pulse: 0/12 V DC
(Load resistance 600 Ω or more)
- Current: 0 to 20 mA DC, 4 to 20 mA DC
(Load resistance 600 Ω or less)
- Voltage: 0 to 5 V DC, 0 to 10 V DC, 1 to 5 V DC
(Load resistance 1 kΩ or more)

■ Control action

Number of controls: 2 points

Control method: Brilliant PID control
Reverse action or direct action is selectable (Specify when ordering)

Additional function: Autotuning function
- With output limiter function
- With output change rate limiter

■ Events

Number of events: 2 points/channel

Event type: Temperature event:
Deviation high, Deviation low,
Deviation high/low, Band,
Process high, Process low

■ Heater break alarm (HBA) function

Number of HBA: 2 points

Setting range: 0.0 to 100.0 A (0.0 A: OFF)

Additional function: Number of event delay times:
1 to 255 times

■ Control loop break alarm (LBA) function

Number of LBA: 2 points

LBA time: 1 to 7200 seconds

LBA deadband (LBD) setting:
0 to Input span

■ Program control

Number of patterns: 16 pattern max.
(With pattern link function)

Number of segments: 16 segment/pattern max.

Time signal output: 16 point/pattern

■ Communications

Communication interface:
Based on RS-485, EIA standard

Communication protocol:
RKC communication
(ANSI X3.28 subcategory 2.5, A4)
or Modbus

Connection: Internal bus

■ Others

Power supply voltage: 24 V DC
(Supplied by temperature control module [basic type])

Power supply voltage range:
21.6 V DC to 26.4 V DC

Current consumption: 120 mA or less/module

Ambient temperature range:
-10 to +50 °C

Ambient humidity range: 5 to 95 %RH (Non condensing)
Absolute humidity:
MAX.W.C 29 g/m³ dry air at 101.3 kPa

Weight: Approx. 190 g

- Modbus is a registered trademark of Schneider Electric.
- Company names and product names used in this manual are the trademarks or registered trademarks of the respective companies.

The first edition: MAY 2002 [IMQ01]
The third edition: JUN. 2003 [IMQ00]

RKC® RKC INSTRUMENT INC.

HEADQUARTERS: 16-6, KUGAHARA 5-CHOME, OHTA-KU
TOKYO 146-8515 JAPAN
PHONE: 03-3751-9799 (+81 3 3751 9799)
E-mail: info@rkinst.co.jp
FAX: 03-3751-8585 (+81 3 3751 8585)