





V-TIO-B/V-TIO-D

Instruction Manual

IMS01P03-E6

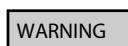
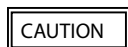
Thank you for purchasing this RKC product. In order to achieve maximum performance and ensure proper operation of your new instrument, carefully read all the instructions in this manual. Please place this manual in a convenient location for easy reference.

SYMBOLS

-  : This mark indicates precautions that must be taken if there is danger of electric shock, fire, etc., which could result in loss of life or injury.
-  : This mark indicates that if these precautions and operating procedures are not taken, damage to the instrument may result.
-  : This mark indicates that all precautions should be taken for safe usage.
-  : This mark indicates important information on installation, handling and operating procedures.
-  : This mark indicates supplemental information on installation, handling and operating procedures.
-  : This mark indicates where additional information may be located.



WARNING

- An external protection device must be installed if failure of this instrument could result in damage to the instrument, equipment or injury to personnel.
- All wiring must be completed before power is turned on to prevent electric shock, fire or damage to instrument and equipment.
- This instrument must be used in accordance with the specifications to prevent fire or damage to instrument and equipment.
- This instrument is not intended for use in locations subject to flammable or explosive gases.
- Do not touch high-voltage connections such as power supply terminals, etc. to avoid electric shock.
- RKC is not responsible if this instrument is repaired, modified or disassembled by other than factory-approved personnel. Malfunction can occur and warranty is void under these conditions.

CAUTION

- This is a Class A instrument. In a domestic environment, this instrument may cause radio interference, in which case the user may be required to take adequate measures.

- This instrument is protected from electric shock by reinforced insulation. Provide reinforced insulation between the wire for the input signal and the wires for instrument power supply, source of power and loads.
- Be sure to provide an appropriate surge control circuit respectively for the following:
 - If input/output or signal lines within the building are longer than 30 meters.
 - If input/output or signal lines leave the building, regardless the length.
- This instrument is designed for installation in an enclosed instrumentation panel. All high-voltage connections such as power supply terminals must be enclosed in the instrumentation panel to avoid electric shock by operating personnel.
- All precautions described in this manual should be taken to avoid damage to the instrument or equipment.
- All wiring must be in accordance with local codes and regulations.
- All wiring must be completed before power is turned on to prevent electric shock, instrument failure, or incorrect action.

The power must be turned off before repairing work for input break and output failure including replacement of sensor, contactor or SSR, and all wiring must be completed before power is turned on again.

- To prevent instrument damage or failure, protect the power line and the input/output lines from high currents with a protection device such as fuse, circuit breaker, etc.
- Prevent metal fragments or lead wire scraps from falling inside instrument case to avoid electric shock, fire or malfunction.
- Tighten each terminal screw to the specified torque found in the manual to avoid electric shock, fire or malfunction.
- For proper operation of this instrument, provide adequate ventilation for heat dissipation.
- Do not connect wires to unused terminals as this will interfere with proper operation of the instrument.
- Turn off the power supply before cleaning the instrument.
- Do not use a volatile solvent such as paint thinner to clean the instrument. Deformation or discoloration will occur. Use a soft, dry cloth to remove stains from the instrument.
- To avoid damage to instrument display, do not rub with an abrasive material or push front panel with a hard object.
- Do not connect modular connectors to telephone line.

NOTICE

- This manual assumes that the reader has a fundamental knowledge of the principles of electricity, process control, computer technology and communications.
- The figures, diagrams and numeric values used in this manual are only for purpose of illustration.
- RKC is not responsible for any damage or injury that is caused as a result of using this instrument, instrument failure or indirect damage.
- RKC is not responsible for any damage and/or injury resulting from the use of instruments made by imitating this instrument.
- Periodic maintenance is required for safe and proper operation of this instrument. Some components have a limited service life, or characteristics that change over time.
- Every effort has been made to ensure accuracy of all information contained herein. RKC makes no warranty expressed or implied, with respect to the accuracy of the information. The information in this manual is subject to change without prior notice.
- No portion of this document may be reprinted, modified, copied, transmitted, digitized, stored, processed or retrieved through any mechanical, electronic, optical or other means without prior written approval from RKC.

1. OUTLINE

Two [basic types] of temperature control (TIO) modules are available: the V-TIO-B for heat control and the V-TIO-D for heat/cool control.

As the temperature control (TIO) module [extension type] is not provide with power supply and host communication terminals, communication with the host computer is always made with this module connected to the temperature control (TIO) module [basic type]. In addition, one digital input (DI) point and two digital output (DO) points can be optionally added.

 All data are set by communication. For details, see the Module Type Controller SRV Communication Instruction Manual (IMS01P01-E□).

2. PRODUCT CHECK

Before using this product, check each of the following:

- Model code
- Check that all of the accessories delivered are complete.
- Check that there are no scratch or breakage in external appearance (case, front panel, or terminal, etc).

V-TIO- □ □ □□□ - □ □ *□ □ □ - □ □ - □ - □ /Y
 (1) (2) (3) (4) (5) (6) (7) (8) (9) (10) (11) (12)

(1) Type

- B: Extension type, heat control
- D: Extension type, heat/cool control

(2) Control action

[For heat control]

- F: PID action with autotuning (AT) (reverse action)
- D: PID action with autotuning (AT) (direct action)

[For heat/cool control]

- B: Heat/cool PID action with autotuning (AT) (air cooling)
- W: Heat/cool PID action with autotuning (AT) (water cooling)

(3) Input range (Each channel common code)

[Thermocouple input]

Type	Code	Range	Code	Range
K	K02	0 to 400 °C	KB9	32 to 752 °F
	K04	0 to 800 °C	KB8	32 to 1472 °F
	K16	-200 to +1372 °C	KB7	-328 to +2501 °F
	K09	0.0 to 400.0 °C	KC2	32.0 to 752.0 °F
	K35	-200.0 to +400.0 °C	KC1	-328.0 to +752.0 °F
J	J02	0 to 400 °C	JC2	32 to 752 °F
	J04	0 to 800 °C	JC1	32 to 1472 °F
	J15	-200 to +1200 °C	JB9	-328 to +2192 °F
	J09	0.0 to 400.0 °C	JC4	32.0 to 752.0 °F
	J27	-200.0 to +400.0 °C	JC3	-328.0 to +752.0 °F
	T	T08	0 to 400 °C	TB9
T09		0 to 200 °C	TC1	32 to 392 °F
T16		-200 to +400 °C	TB8	-328 to +752 °F
T06		0.0 to 400.0 °C	TC3	32.0 to 752.0 °F
T19		-200.0 to +400.0 °C	TC2	-328.0 to +752.0 °F
E		E01	0 to 800 °C	EA8
	E02	0 to 1000 °C	EA7	32 to 1832 °F
S	S05	0 to 1768 °C	SA6	32 to 3214 °F
R	R06	0 to 1768 °C	RA6	32 to 3214 °F
N	N02	0 to 1300 °C	NA6	32 to 2372 °F
B	B03	0 to 1800 °C	BB1	32 to 3272 °F
PL II	A02	0 to 1390 °C	AA6	32 to 2534 °F
W5Re/ W26Re	W03	0 to 2300 °C	WA9	32 to 4172 °F

[RTD input]

Type	Code	Range	Code	Range
Pt100	D17	0 to 400 °C	DC5	32 to 752 °F
	D33	0 to 850 °C	DC4	32 to 1562 °F
	D16	0.0 to 400.0 °C	DC7	32.0 to 752.0 °F
	D28	-200.0 to +400.0 °C	DC6	-328.0 to +752.0 °F
	JPt100	P17	0 to 400 °C	PC5
P23		0 to 600 °C	PC4	32 to 1112 °F
P16		0.0 to 400.0 °C	PC7	32.0 to 752.0 °F
P28		-200.0 to +400.0 °C	PC6	-328.0 to +752.0 °F

[Voltage/current input]

	Code	Type	Code	Type
Voltage	201	0 to 100 mV DC	401	0 to 5 V DC
	501	0 to 10 V DC	601	1 to 5 V DC
Current	701	0 to 20 mA DC	801	4 to 20 mA DC

(4) Control output (CH1), (5) Control output (CH2)

M: Relay contact output

V: Voltage pulse output 0/12 V DC

4: 0 to 5 V DC 5: 0 to 10 V DC 6: 1 to 5 V DC

7: 0 to 20 mA DC 8: 4 to 20 mA DC

(6) Event input (DI) [Optional]

N: None

1: Control RUN/STOP

2: Event interlock release

(7) (8) Event output 1 (DO1) [Optional]

(9) (10) Event output 2 (DO2) [Optional]

[(7), (9) code: Channel selection]

N: None 1: Input channel 1 2: Input channel 2

[(8), (10) code: Output type]

N: None A: Deviation high B: Deviation low

C: Deviation high/low D: Band

E: Deviation high with hold action F: Deviation low with hold action

G: Deviation high/low with hold action

H: Process high J: Process low

K: Process high with hold action L: Process low with hold action

Q: Deviation high with re-hold action

R: Deviation low with re-hold action

T: Deviation high/low with re-hold action

P: Heater break alarm 1: Control loop break alarm

2: Burnout 3: Temperature rise completion

(11) CT type (Each channel common code)

P: CTL-6-P-N

S: CTL-12-S56-10L-N

(12) Communication function

5: RKC communication (RS-485) 6: Modbus (RS-485)



- For heat/cool PID control (V-TIO-D), input channel 2 becomes unused.
- For heat/cool PID control (V-TIO-D), Control output 1 corresponds to the heating output and Control output 2 corresponds to the cooling output.
- The heater break alarm function becomes invalid when the voltage/current output is selected as control output type.

Accessories

Instruction Manual (IMS01P03-E6)..... 1

3. PARTS DESCRIPTION

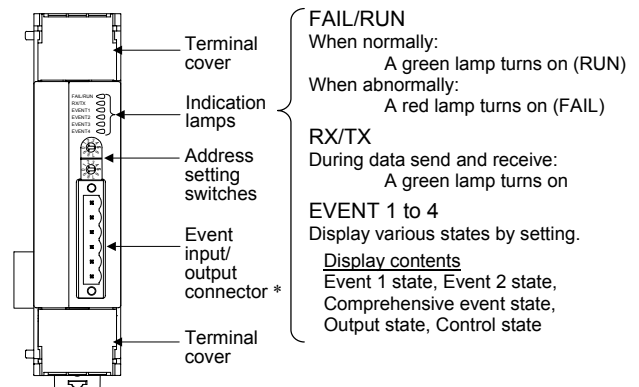

* Installed when provided with the event input/output (optional).

4. COMMUNICATION SETTING

Set communication setting before mounting and wiring of SRV.

CAUTION

Do not separate the module mainframe from the terminal base with the power turned on. If separated, adjusted data may be destroyed; control be stopped, and no return can be made.

4.1 Module Address Setting

Set an address of module. For this setting, use a small blade screwdriver.

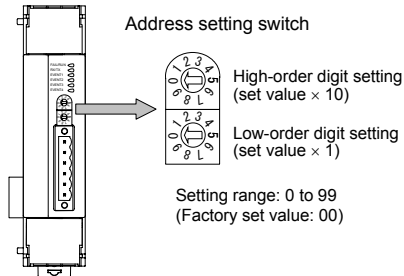

- For Modbus, the value obtained by adding “1” to the set address corresponds to the address used for the actual program.
- To avoid problems or malfunction, do not duplicate an address on the same communication line.



The above figure shows when provided with the event input/output connector, but the same also when not provided with the connector.

4.2 Protocol Selections and Communication Speed Setting

Use the DIP switch on the right side of module to select communication speed, data bit configuration and protocol. The data changes become valid when the power is turned on again or when changed to RUN/STOP.

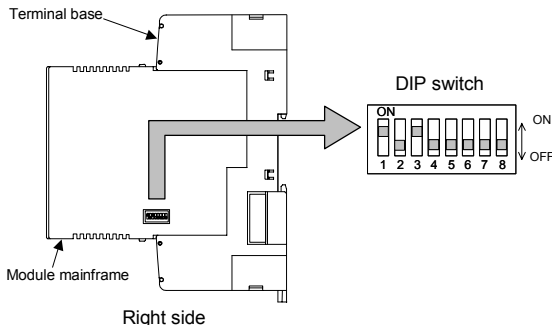

1	2	Communication speed
OFF	OFF	2400 bps
ON	OFF	9600 bps
OFF	ON	19200 bps
ON	ON	38400 bps

Factory set value: RKC communication: 9600 bps
Modbus: 38400 bps

3	4	5	Data bit configuration
OFF	OFF	OFF	Data 7-bit, without parity, Stop 1-bit *
OFF	OFF	ON	Data 7-bit, Even parity, Stop 1-bit *
OFF	ON	ON	Data 7-bit, Odd parity, Stop 1-bit *
ON	OFF	OFF	Data 8-bit, without parity, Stop 1-bit
ON	OFF	ON	Data 8-bit, Even parity, Stop 1-bit
ON	ON	ON	Data 8-bit, Odd parity, Stop 1-bit

* When the Modbus communication protocol is selected, this setting becomes invalid.

Factory set value: Data 8-bit, without parity, Stop 1-bit

6	Protocol selection
OFF	RKC communication
ON	Modbus

Factory set value: Specify when ordering



- Switch No. 7 and 8 must be always OFF. Do not set to ON.
- When two or more modules are connected on the same communication line, the DIP switch settings (switch 1 to 6) of all modules must be the same.
- Be changed into communication time setting mode* by using switch No. 4, 5 and 6.
For communication time setting mode, see the Module Type Controller SRV Communication Instruction Manual (IMS01P01-E□).

5. MOUNTING



WARNING

To prevent electric shock or instrument failure, always turn off the power before mounting or removing the instrument.

5.1 Mounting Cautions

- (1) This instrument is intended to be used under the following environmental conditions. (IEC61010-1) [OVERVOLTAGE CATEGORY II, POLLUTION DEGREE 2]
- (2) Use this instrument within the following environment conditions.
 - Allowable ambient temperature: -10 to +50 °C
 - Allowable ambient humidity: 5 to 95 % RH (Absolute humidity: MAX. W. C 29.3 g/m³ dry air at 101.3 kPa)
 - Installation environment conditions: Indoor use
Altitude up to 2000 m
- (3) Avoid the following when selecting the mounting location:
 - Rapid changes in ambient temperature, which may cause condensation.
 - Corrosive or inflammable gases.
 - Direct vibration or shock to the mainframe.
 - Water, oil, chemicals, vapor or steam splashes.
 - Excessive dust, salt or iron particles.
 - Excessive induction noise, static electricity, magnetic fields or noise.
 - Direct air flow from an air conditioner.
 - Exposure to direct sunlight.
 - Excessive heat accumulation.
- (4) Mounting consideration
 - Install the module 200 mm away from the main power line.
 - Ensure at least 50 mm space on top and bottom of the control unit for maintenance and environmental reasons.

5.2 Dimensions

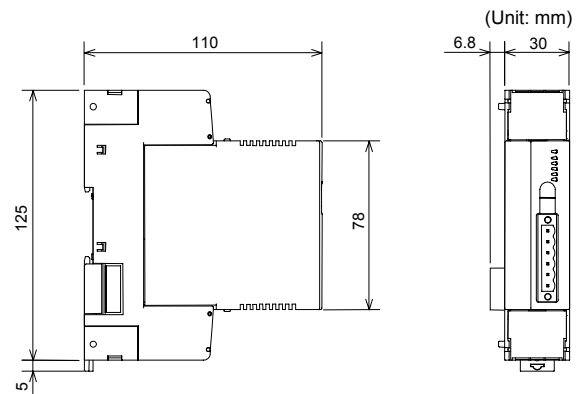

The above figure shows when provided with the event input/output connector, but the same also when not provided with the connector.

● Depth in connector mounting

Conduct installation in consideration of the sizes of the connector and cable when connector-connected.

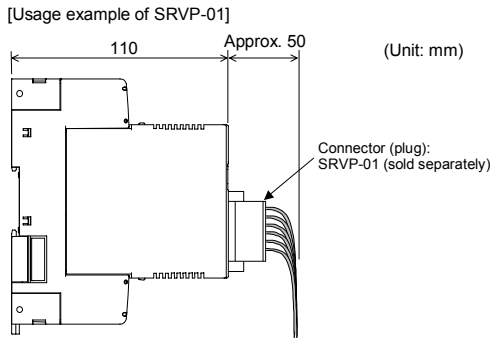

5.3 DIN rail Mounting

■ Mounting procedures

1. Pull down the mounting bracket at the bottom of the module (A). Attach the hooks on the top of the module to the DIN rail and push the lower section into place on the DIN rail (B). (Fig. 1)
2. Slide the mounting bracket up to secure the module to the DIN rail. (Fig. 2)

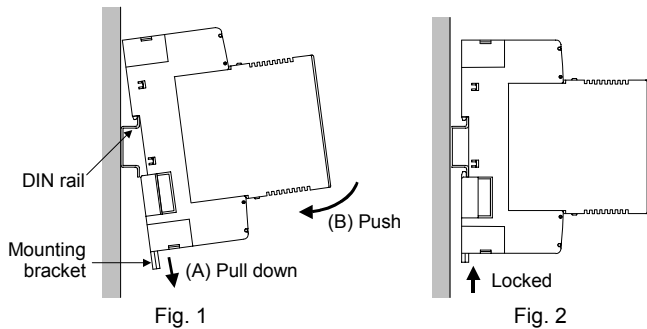

■ End Plate mounting

Hold tight both ends of the modules joined together with the end plates attached to the temperature control module [basic type] and then fix the end plates with screws.

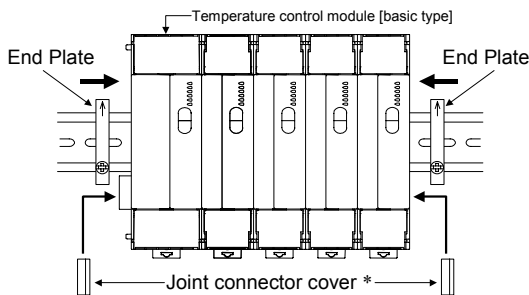

* For the conservation of the contact of connector, install a joint connector cover (be attached to the TIO module [basic type]) in module of both ends.

■ Removing procedures

Pull down a mounting bracket with a blade screwdriver (A). Lift the module from bottom, and take it off (B).

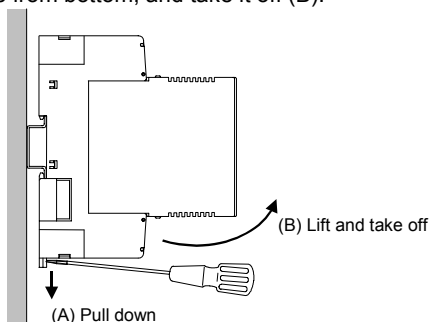

5.4 Panel Mounting

■ Mounting procedures

1. Pull down the mounting bracket (A) until locked and that a mounting hole appears.
2. Prepare one mounting bracket per module (B) sold separately (KSRX-55) and then insert it in the rear of the terminal board at top of the module until locked but a mounting hole does not disappear.
3. Mount each module directly on the panel with screws which are inserted in the mounting holes of the top and bottom mounting brackets.

Recommended tightening torque: 0.3 N·m (3 kgf·cm)

The customer needs to provide the M3 size screws. Select the screw length that matches the mounting panel.

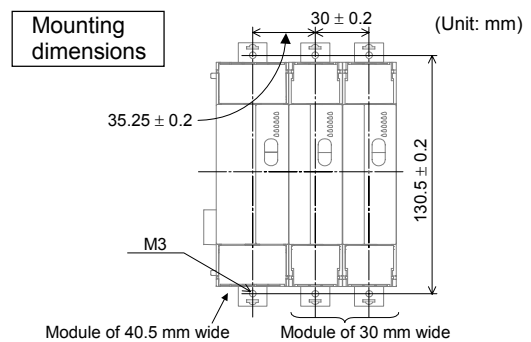
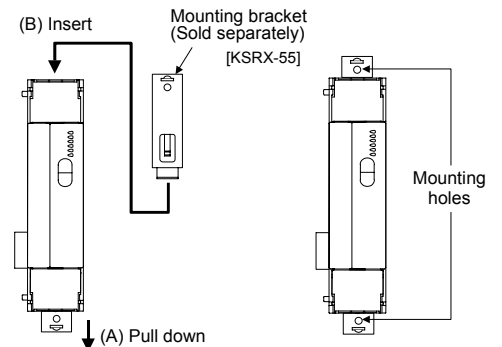

5.5 Jointing Each Module

Up to 31 SRVs consisting of the each modules can be jointed together. Joint these modules according to the following procedure.

■ Jointing procedures

1. Mount the modules on the DIN rail and then joint these modules together with the joint connector while sliding the relevant module.
2. Lift each of the joint tabs located at the top and bottom of the module and then insert it in the slot of the adjacent module to fix these two modules.

For panel mounting, first joint each module and then mount it on the panel.

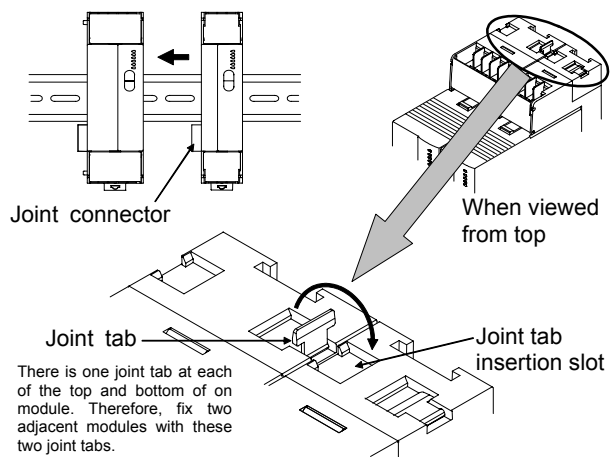

6. WIRING



WARNING

To prevent electric shock or instrument failure, do not turn on the power until all the wiring is completed.

6.1 Wiring Cautions

- For thermocouple input, use the appropriate compensation wire.
- For RTD input, use low resistance lead wire with no difference in resistance between the three lead wires.
- To avoid noise induction, keep input signal wire away from instrument power line, load lines and power lines of other electric equipment.

6.2 Terminal Configuration

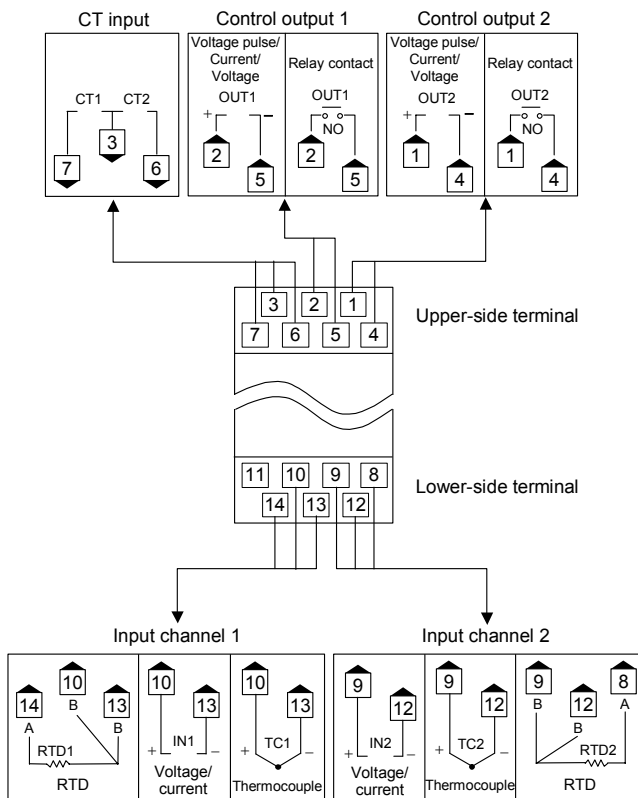

- For heat/cool PID control (V-TIO-D), Input channel 2 becomes unused.
- For heat/cool PID control (V-TIO-D), Control output 1 corresponds to the heating output and Control output 2 corresponds to the cooling output.



- Terminal No. 11 is not used.
- Use the solderless terminal appropriate to the screw size (M3).

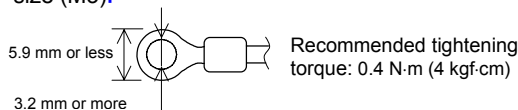

6.3 Pin Layout of Connector

- When there is the event input/output

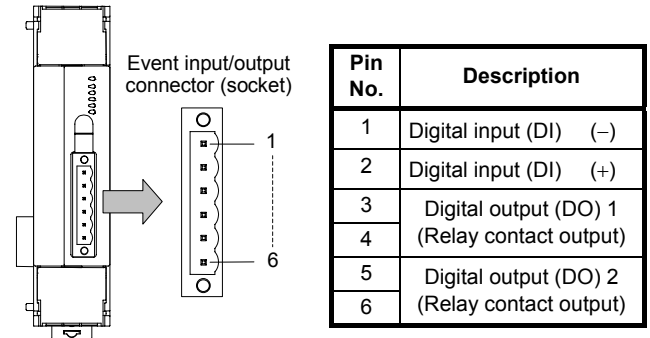

- Circuit configuration

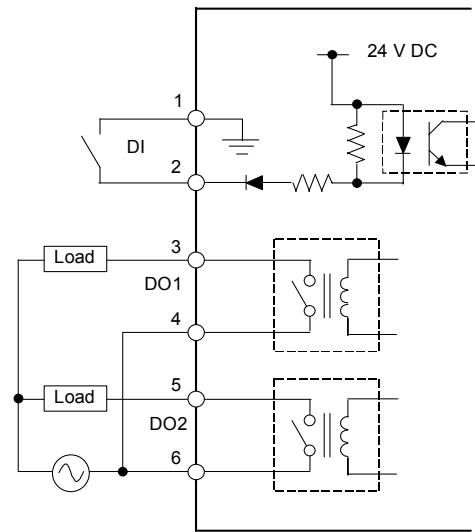

6.4 Attention in Connector (plug) Wiring

- Use the following connector (plug) as that connected to the event input/output connector. Connector (plug) is sold separately.
SRVP-01 (Front-screw type)
SRVP-02 (Side-screw type)
- The lead wires use the stranded wire.
- Use the stranded wire from size 0.2 to 2.5 mm² (AWG 24-12).
- Stripping length is as follows.
SRVP-01: 10 mm
SRVP-02: 7 mm
- Recommended tightening torque of the lead wire in the connector (plug): 0.5 to 0.6 N-m (5 to 6 kgf-cm)
(Screw size: SRVP-01: M2.5
SRVP-01: M3)

[SRVP-01] Front-screw type

[SRVP-02] Side-screw type

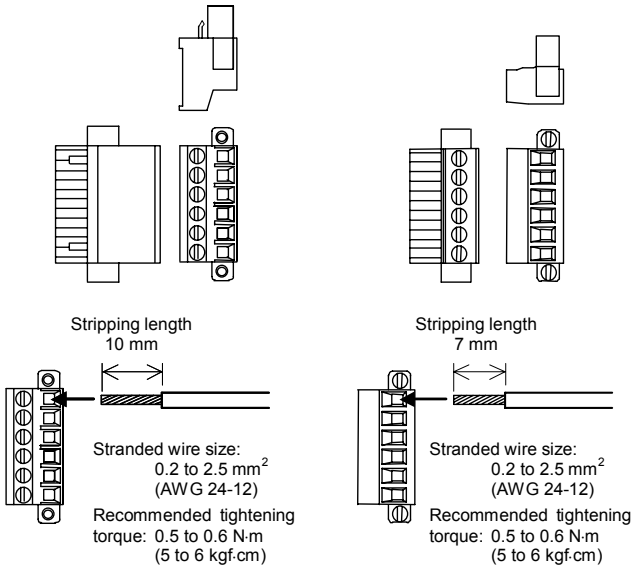

7. SPECIFICATIONS

Inputs

Number of inputs: 2 points
 Isolated between each channel:
 Thermocouple input, Voltage (low) input
 Not isolated between each channel:
 RTD input, Voltage (high) input,
 Current input

Input type:

- Thermocouple K, J, T, S, R, E, B, N (JIS-C1602-1995)
 PLII (NBS)
 W5Re/W26Re (ASTM-E988-96)
- RTD Pt100, JPt100
- Voltage (low) 0 to 100 mV
- Voltage (high) 0 to 5 V, 0 to 10 V, 1 to 5 V
- Current 0 to 20 mA, 4 to 20 mA

Sampling cycle: 500 ms
 PV bias: -Input span to +Input span
 CT input: 2 points
 0.0 to 30.0 A (CTL-6P-N) or
 0.0 to 100.0 A (CTL-12-S56-10L-N)

Outputs

Number of outputs: 2 points
 (Isolated between input and output, and
 between output and power supply)

Output type:

- Relay contact: 250 V AC, 3 A (Resistive load)
 1a contact
 Electrical life 300,000 times or more
 (Rated load)
- Voltage pulse: 0/12 V DC
 (Load resistance 600 Ω or more)
- Current: 0 to 20 mA DC, 4 to 20 mA DC
 (Load resistance 600 Ω or less)
- Voltage: 0 to 5 V DC, 0 to 10 V DC, 1 to 5 V DC
 (Load resistance 1 kΩ or more)

Control action

Number of controls: 2 points
 Control method: Brilliant PID control
 Reverse action or direct action is
 selectable (Specify when ordering)
 Heat/cool control is selectable
 (Specify when ordering)
 Additional function: Autotuning function

Events

Number of events: 2 points/channel
 Event type: Temperature event:
 Deviation high, Deviation low,
 Deviation high/low, Band,
 Process high, Process low
 Heater break alarm,
 Control loop break alarm,
 Burnout, Temperature rise completion

Option

Event input

Number of inputs: 1 point
 Input type: Dry contact input
 Input voltage: 24 V DC (Rated)
 Input current: Approx. 6 mA
 Input details: Control RUN/STOP,
 Event interlock release
 (Specify when ordering)

Event output

Number of outputs: 2 points
 Output type: Relay contact output
 250 V AC, 1 A (Resistive load)
 1a contact
 Electrical life 300,000 times or more
 (Rated load)
 Output details: Temperature event, Heater break alarm,
 Control loop break alarm, Burnout,
 Temperature rise completion
 (Specify when ordering)

Communications

Communication interface: Based on RS-485, EIA standard
 Communication protocol: RKC communication
 (ANSI X3.28 subcategory 2.5, A4)
 or Modbus
 Internal bus
 Connection:

Others

Power supply voltage: 24 V DC
 (The power is supplied from temperature
 control module [basic type].)
 Power supply voltage range:
 21.6 V DC to 26.4 V DC
 Current consumption: With event input/output (option):
 120 mA max./module
 Without event input/output (option):
 90 mA max./module
 Allowable ambient temperature range:
 -10 to +50 °C
 Allowable ambient humidity range:
 5 to 95 %RH (Non condensing)
 Absolute humidity:
 MAX.W.C 29.3 g/m³ dry air at 101.3 kPa
 Installation environment conditions:
 Indoor use
 Altitude up to 2000 m
 Weight: With event input/output (option):
 Approx. 180 g
 Without event input/output (option):
 Approx. 170 g

- Modbus is a registered trademark of Schneider Electric.
- Company names and product names used in this manual are the trademarks or registered trademarks of the respective companies.

The first edition: SEP. 2002 [IMQ00]
 The sixth edition: OCT. 2006 [IMO001]

RKC® RKC INSTRUMENT INC.

HEADQUARTERS:16-6, KUGAHARA 5-CHOME, OHTA-KU
 TOKYO 146-8515 JAPAN
 PHONE: 03-3751-9799 (+81 3 3751 9799)
 E-mail: info@rkcinst.co.jp
 FAX: 03-3751-8585 (+81 3 3751 8585)