



AIR AMPLIFIERS

PERFORMANCE • QUALITY • RELIABILITY



Introduction

Haskel air pressure amplifiers offer the most comprehensive range in the industry combining simple principles of operation with rugged construction suitable for the most demanding industrial applications.

Why use Haskel Air Amplifiers?

An alternative to the purchase of a dedicated high pressure compressor, Haskel air amplifiers are compact, require no electrical or mechanical drive connections, are powered by the same air that they amplify, and can be mounted in any position.

Key Features

- Long seal life and easy maintenance
- No heat, flame or spark risk.
- Wide range of models, controls, and options.
- No air line lubrication required eliminating oily exhaust.
- Infinitely variable outlet pressure and flow capability.
- Wide range of standard and custom systems.
- Control of maximum pressure by means of inexpensive air drive pressure regulators.

What is a Haskel Air Amplifier?

An Air Pressure Amplifier is an air pump that is driven by part of the incoming compressed air supply enabling it to cycle and pump the balance of the supply to a higher output pressure. Pressure is generated by the use of a differential area piston assembly (Fig 1). Low pressure air applied to a large area creates high pressure air on the small area. Cycling is achieved through the use of two pilot valves that alternately pilot and vent the large area end of an unbalanced cycling spool. The small area end of the cycling spool uses a permanent air spring. This unbalanced cycling spool ensures that the air amplifier cycles on demand.

Unique seal technology enables the drive section of its pressure generating products to operate without air line lubrication. No lubrication of any kind is used in the high pressure sections where non-metallic bearings and wear compensating seals are employed.

The ratio of the areas between the connected pistons is called the area ratio and is the dash number used in all model codes. This ratio and the available air drive source pressure determines the maximum outlet pressure of the air amplifier.

The completely sealed air amplifier will “stall” at its maximum capable outlet pressure and consume no energy or generate any heat while doing so. When pressure drop is seen at the air amplifier outlet, the unbalanced spool ensures cycling to make up the pressure loss and will again “stall” after having done so.

Double acting and two stage models are available which provide increased output and efficiency as well as using input air directly on the high pressure piston(s) in both stroke directions to increase drive force and output pressure capability.

A proven range of horsepower sizes is available to meet most high pressure air requirements; from our 1/3 HP for low flow/static applications to our 8 HP used for high flow dynamic applications.

Figure 1

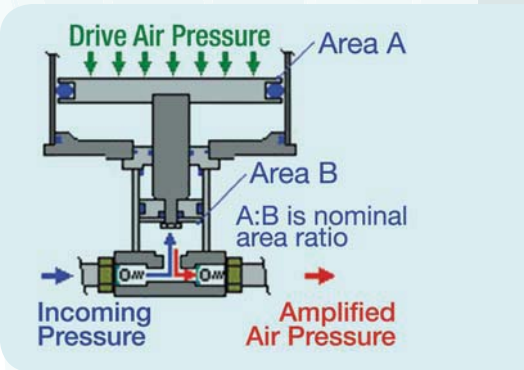

AAD-2

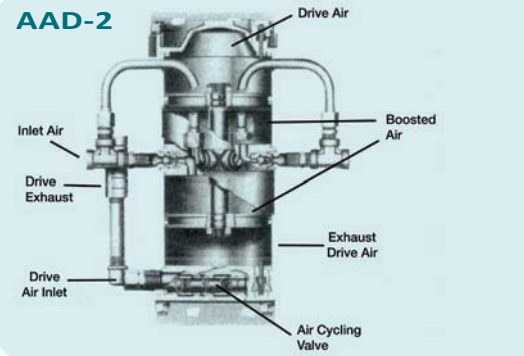

AAD-5

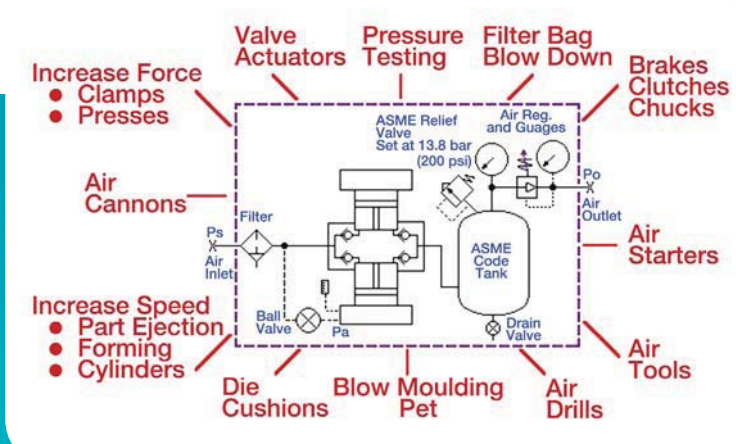
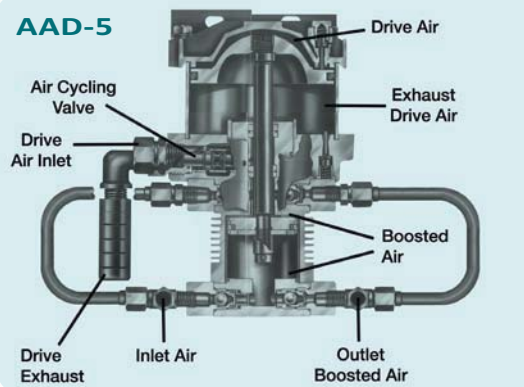

Typical Applications

Sizing Air Amplifiers

Several factors are involved in the proper sizing of Haskel air amplifiers. Some involve the specific parameters of the application while some involve the application itself.

Specific parameters include:

- What is the outlet pressure required (Po)?
- What is the minimum available air drive pressure (Pa)?
- What is the available air drive flow (Qa)?
- What is the supply pressure (Ps)? (In most cases, Pa = Ps)
- What is the required flow (Q) at the outlet pressure?

Application data includes:

- What is the duty cycle?
- What is the high pressure required for?

Testing — what is the volume of the vessel and time required?

Part Ejection — what is the cycle of volume requirements?

Actuation — what is the bore & stroke of the actuator(s)?

- single or double acting?
- is high pressure air required on each stroke (double acting)?
- Which stroke?
- is high pressure air required for the entire stroke length(s)?
- what are the cycle requirements?

Selecting Required Ratio

Dividing the outlet pressure (Po) by the drive pressure (Pa) will provide us with the minimum area ratio of the amplifier(s). The dash number in the model code represents the area ratio.

More than one amplifier may be required: in certain high flow or heavy duty applications two or more amplifiers can be used in parallel; in certain higher flow/high pressure applications, a two-stage amplifier or multiple amplifiers can be used in series. Haskel offers a range of standard multipump units. Multipump units are most effective when the models selected produce the same flow for their respective pressure amplification.

Multi Pump Units

AAD-2-D5-C
AAD-5-15-C
AAD-5-D25-C
AAD-5-30-C
AAD-5-D30-C
AAD-5-15/30-C

Determining Flow

We should verify the of flow required (Q) by evaluating the application data. Finding that high pressure air is required only at the end of stroke or only on one stroke of the cycle may reduce the initial assessment of flow (Q).

Another consideration will be whether an air receiver used downstream can reduce the size of the amplifier required when the system cycle is taken into account (use high pressure air from the receiver during the on cycle and recharge the receiver during the off cycle) or enable momentary high flow requirements that initially are thought to exceed the capacity of our units. Haskel offers system options that include air receivers and controls.

Operation Guidelines

While Haskel manufactures air amplifiers for a wide range of pressures, care must be taken when sizing units for high outlet pressure applications. All air contains moisture and as you compress air, the moisture level does not reduce along with the volume of the air. The result is the same volume of moisture in a reduced volume of air. This saturation can lead to excessive maintenance for the air amplifier and the system. Dry, inexpensive gases such as nitrogen can be effectively used in the high pressure sections for these higher outlet pressure requirements (600PSIG and higher for example). For critical gas quality, refer to the use of our gas booster compressors which feature separation between drive and high pressure sections.

Other considerations include cycling rate and operation in unloaded conditions (i.e., before supply pressure has equalized or with small differential between supply and outlet pressures).

Cycling rate will be a factor of outlet pressure but can also be controlled by “throttling” the air drive volume. Various manual and

automatic controls are available to prevent “no load runaway” and are illustrated in sections of this catalog pertaining to their respective drive series (see Controls and Options Pg. 10 for details).

Cycle Rates

The maximum outlet flow and cycling speed are represented on the performance curves at the point where the outlet pressure and supply/drive curves intersect. These maximum cycling rates are not recommended for continuous duty (where the pressure and flow requirements for a system are constant) and the air amplifier performance should be derated for these applications to approximately 50% of maximum. Cycling speed at a given outlet flow can be calculated by dividing the outlet flow by the ‘free air volume’ displacement per cycle. The ‘free air volume’ for each air amplifier model can be calculated from the Piston Displacement per cycle (Db).

Piston Displacement per cycle data is shown in the Model Selection chart.

When the maximum outlet flow from a performance curve has been determined, it can be converted to cycling speed by dividing the outlet flow by the ‘free air volume’ displacement per cycle. This cycling speed can be then de-rated for a continuous duty application and converted to rated continuous outlet flow (multiply ‘free air volume’ displacement per cycle x de-rated cycle speed) for improved seal life.

Multiple units can be used in parallel if necessary to meet required outlet flows and maintain acceptable cycle rates for continuous duty applications.

Guidelines for Continuous Duty Applications for Maximizing Seal Life Performance

Air Amplifier Series	Maximum Cycles per minute
HAA31	325
4AAD-225	225
AA, AAD & AAT	80
8AAD-2	50

Examples:

$$N \text{ Liters/Cycle} = \frac{Db}{1.0} \times \frac{Ps + 1.0}{0.85}$$

Where: Db = Piston Displacement per cycle (Liters)
 Ps = Supply Pressure (bar)
 Adding & dividing by 1.0 converts to Absolute Atmospheres
 0.85 = Efficiency factor (approximate)

$$SCF / \text{Cycle} = \frac{Db}{1728} \times \frac{Ps + 14.7}{14.7} \times 0.85$$

Where: Db = Piston Displacement per cycle (cu. in.)
 Ps = Supply Pressure (psi)
 Adding & dividing by 14.7 converts to Absolute Atmospheres
 0.85 = Efficiency factor (approximate)

Model Selection Chart

Model	Drive Size In (mm)	Max Air Drive PSIG (BAR)	Ratio	Max Inlet PSIG (BAR)	Max Outlet PSIG (BAR)	Displ/Cycle In ³ Cu. In. (nL)
HAA31-2.5	2.87 (73)	125 (9)	2.5:1	125 (9)	320 (22)	2.40 (39.3)
HAA31-3.5	2.87 (73)	125 (9)	3.5:1	125 (9)	450 (31)	1.77 (29.0)
HAA31-4.5	2.87 (73)	125 (9)	4.5:1	125 (9)	600 (41)	1.35 (22.1)
4AAD-2	4 (102)	125 (9)	2:1	250 (1723)	250 (17)	62.5 (1024)
AA-8	5.75 (146)	150 (10)	8:1	1250 (86)	2500 (172)	13.2 (216)
AA-15	5.75 (146)	150 (10)	15:1	2250 (155)	2250 (155)	6.2 (101)
AA-30	5.75 (146)	150 (10)	30:1	4500 (310)	4500 (310)	3.1 (51)
AAD-2	5.75 (146)	150 (10)	2:1	300 (20)	300 (20)	201 (3294)
AAD-5	5.75 (146)	150 (10)	*5:1 (4:1)	1250 (86)	1250 (86)	19.3 (316)
AAD-15	5.75 (146)	150 (10)	15:1	2500 (172)	2500 (172)	12.4 (203)
AAD-30	5.75 (146)	150 (10)	30:1	4500 (310)	4500 (310)	6.2 (101)
AAT-7/30	5.75 (146)	150 (10)	7/30	300 (20)	4500 (310)	13.2 (216)
AAT-15/30	5.75 (146)	150 (10)	15/30	1000 (69)	4500 (310)	6.2 (101)
AAT-30/50	5.75 (146)	150 (10)	30/50	3000 (206)	5000 (344)	3.1 (51)
8AAD-2	8 (203)	130 (896)	2:1	300 (20)	300 (20)	400 (6555)

Using Performance Curves

All Haskel air amplifiers are variable pressure, variable flow devices within the limits of their sizes and ratios. Outlet pressure can be controlled by regulating the air drive and/or air supply pressure (depending on model) while outlet flow can be controlled by adjusting the air flow to the drive piston with a corresponding change in cycle rate.

Performance curves are provided for the various ratios for each horsepower size. The curves provide performance data for the most commonly requested parameters. Performance values for other parameters can either be interpolated from the curves provided or your local Haskel representative can assist you.

Note that as the outlet pressure increases, flow decreases. The maximum outlet pressure is a zero flow condition known as "stall" where the amplifier is maintaining pressure downstream. When it senses a drop in the downstream pressure, it will automatically cycle (the benefit of the unbalanced cycling spool) to raise the system pressure to the "stall" condition again, provided the consumption of air resulting in the pressure drop is within the flow capacity of the model selected.

The curves are easily read by comparing the required outlet pressure with the (available) air drive/supply curve and meeting the corresponding outlet air flow. The total required air volume will be the sum of both the outlet flow and the air drive consumed to cycle the air amplifier ($Q + Q_a = \text{total air volume required}$).

In the example shown: $P_s = 100\text{PSIG}$, $P_o = 170\text{PSIG}$, $Q = 30\text{SCFM}$, $Q_a = 50\text{SCFM}$ (total air volume required is 80SCFM).

Performance Curves

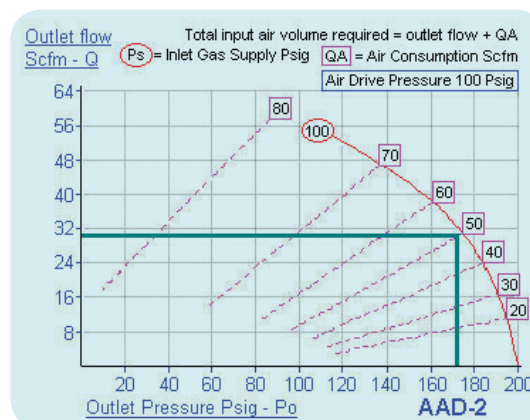

Model Number Codes HAA31 & AA

Single acting, single stage air pressure amplifier.

Maximum Po ("Stall") = $P_a \times \text{Ratio}$

AAD

Double acting, single stage air pressure amplifier provides outlet flow on each stroke of cycle and gains "lift" from inlet pressure.

Maximum Po ("Stall") = $P_a \times \text{Ratio} + P_s$ (*Often $P_a = P_s$)

AAT

Two-stage air pressure amplifier provides two high pressure pistons of different ratios within a single unit for maximum efficiency at higher outlet pressures.

Maximum Po ("Stall") = $P_a \times \text{Ratio}$ 2nd Stage + $P_s \times \text{Ratio}$ Stages

Legend

P_a = Air Drive Pressure
 P_o = Outlet Pressure
 P_s = Supply Inlet Pressure

HAA31 Series, Single Acting, Single Stage

Performance Curves

HAA31-4.5

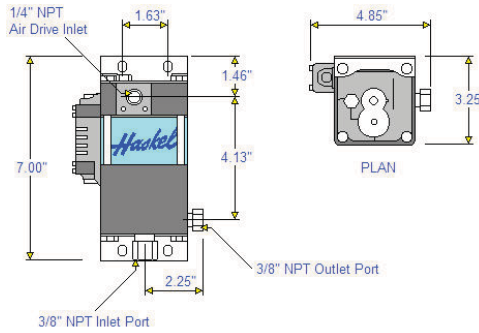
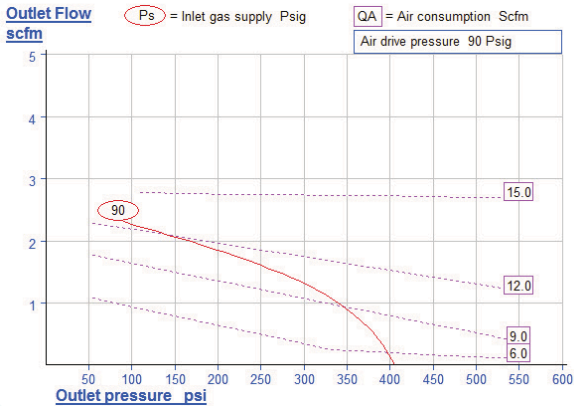

- Economical means of boosting pressure, where volume is small
- Maximum outlet pressure area ratio x drive pressure



HAA31-2.5

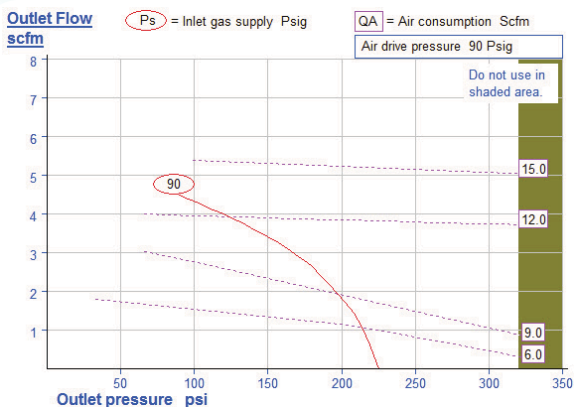

HAA31-3.5

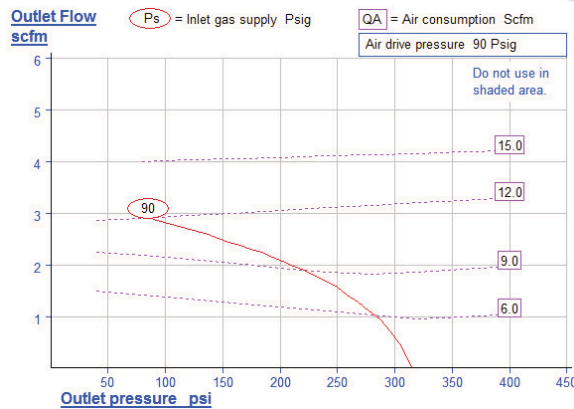

Optional Modifications

Number	Description
-C	Air Controls

Model 85291 Mini System with Receiver and Controls

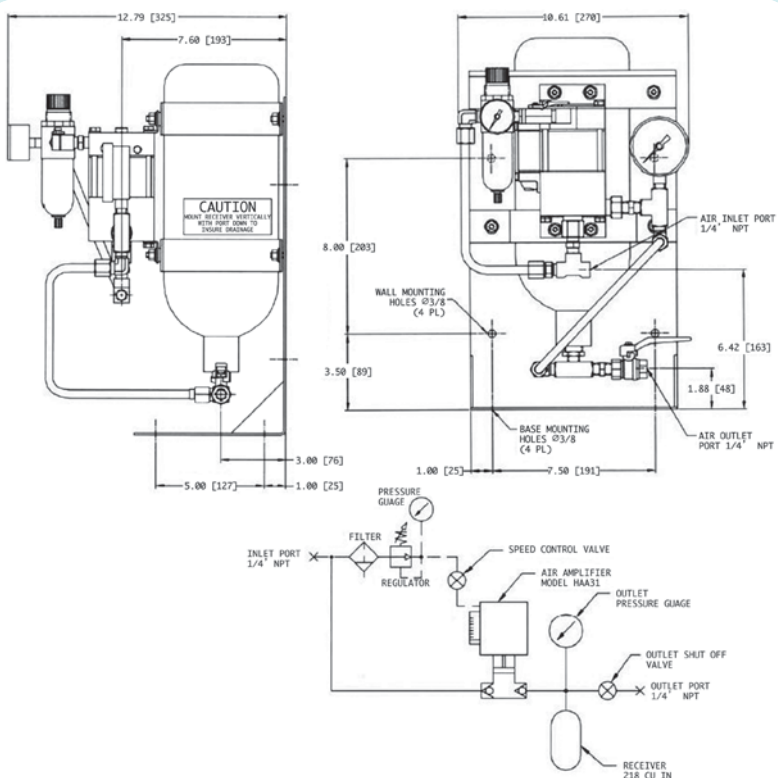

4AAD-2 Series Double Acting, Single Stage

Performance

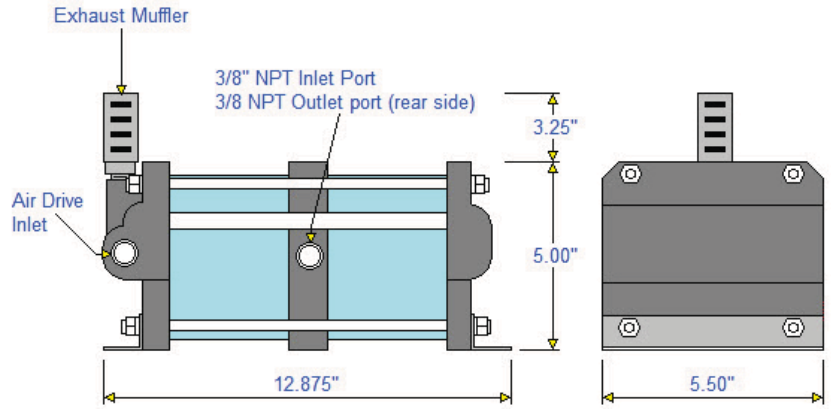
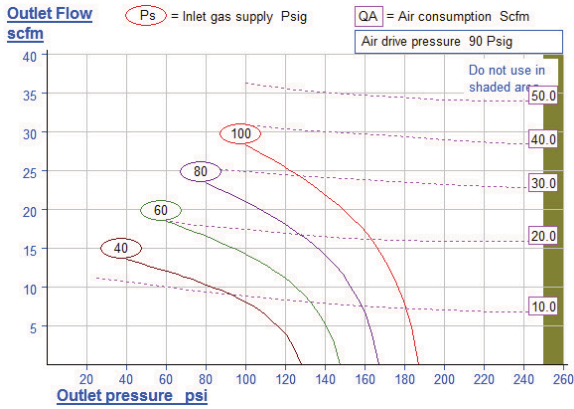

Model 56569 Modification Schematic

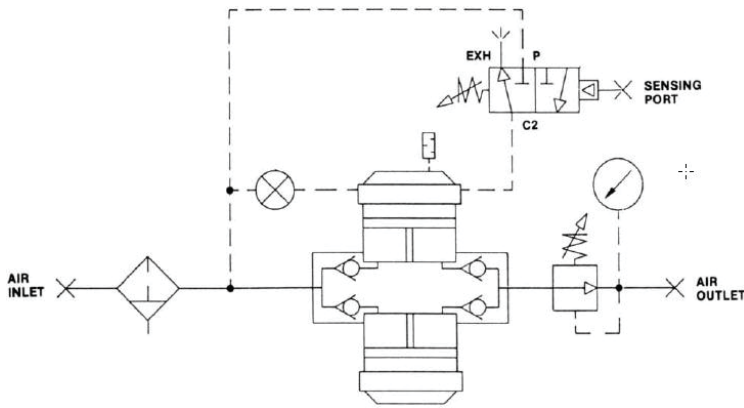

Optional Modifications

Number	Description
-C	Air Controls
56594	External Pilot
56569	No Load Run Away & Regulator
56564	Extreme Service Cycling
56570	Receiver & Controls

Model 56570

4" system on 5¾ gal., 290 psi ASME code receiver with controls and ASME relief valve

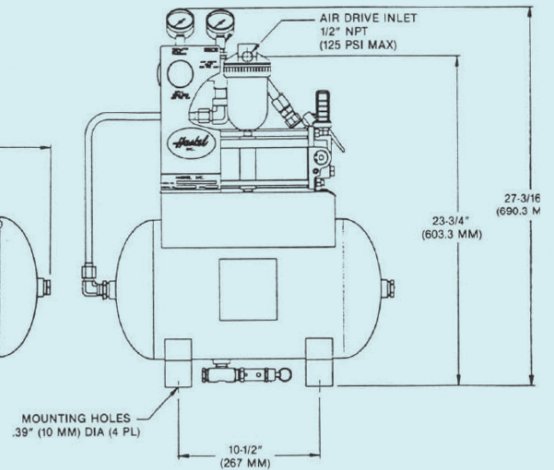
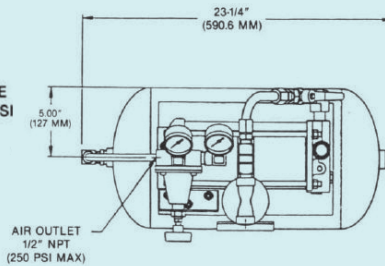
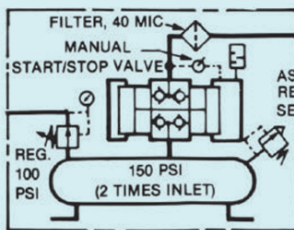

AA Series Single Acting, Single Stage

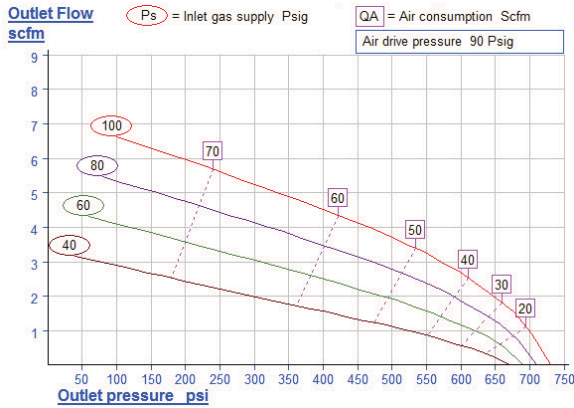
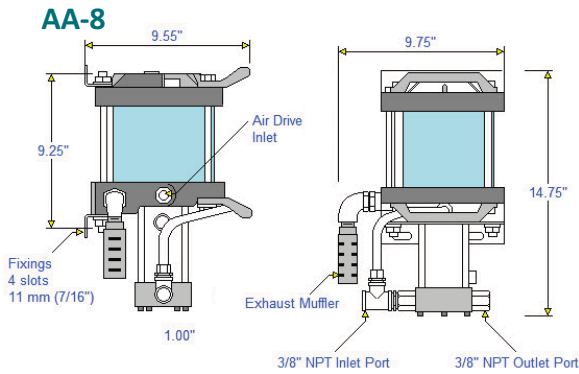

- Pressure outputs up to 4500 psi (310 bar)
- Maximum outlet pressure area ratio x drive pressure

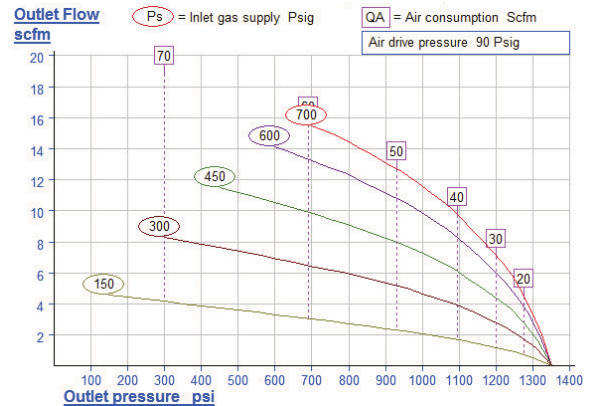
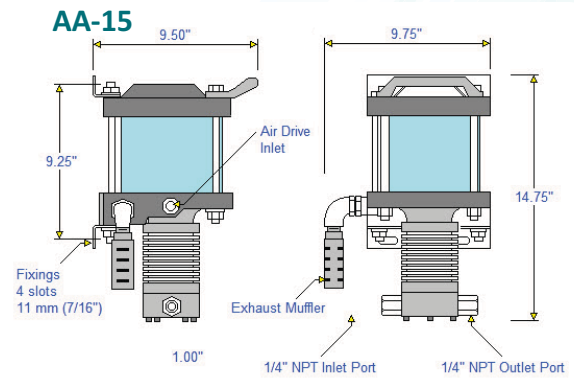
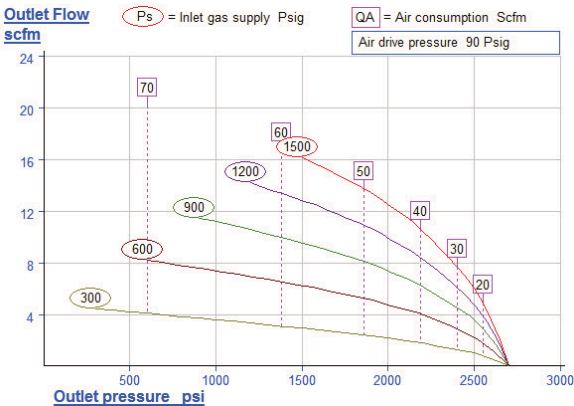
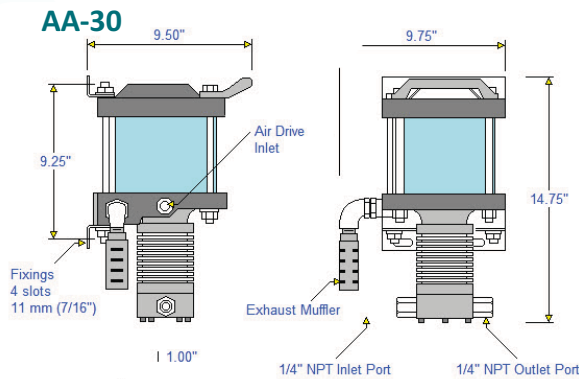

Optional Modifications

Number	Description
-C	Air Controls
28881	External Pilot Modification
17860	Electrical Stroke Counter
25721	Mechanical Stroke Counter
29376	Three Way Cycling Spool

Number	Description
29702	Single Stroke Modification
51050	Extreme Service Cycling
53375	125PSIG Downstream Regulator AAD-2

Number	Description
53375-1	200PSIG Downstream Regulator AAD-2
53376	Regulator, Air Pilot Switch, & Relief Valve AAD-5

AAD Series, Double Acting, Single Stage

- Efficient means of increasing air pressure
- Pressure outputs up to 4500 psi (310 bar)
- Maximum outlet pressure area ratio + supply pressure
- Pump twice volume per cycle of AA range
- Requires less air drive since the inlet air pressure itself provides a substantial portion of the driving force



AAD-2

AAD-2

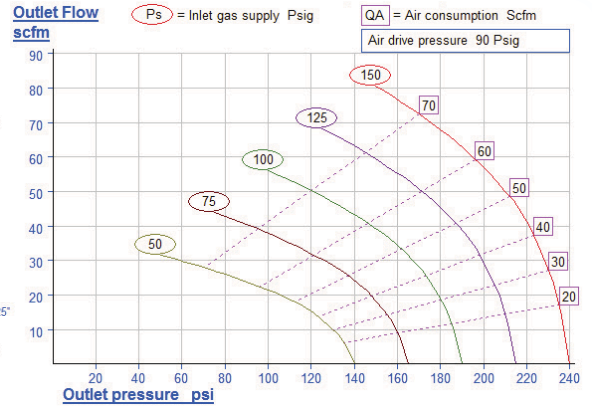
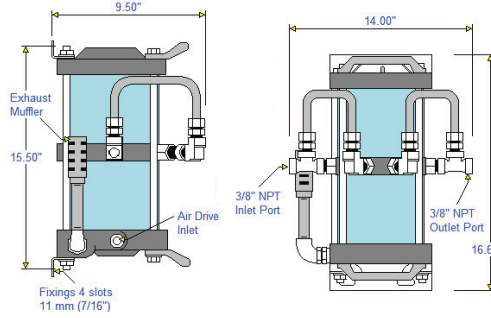

AAD-5

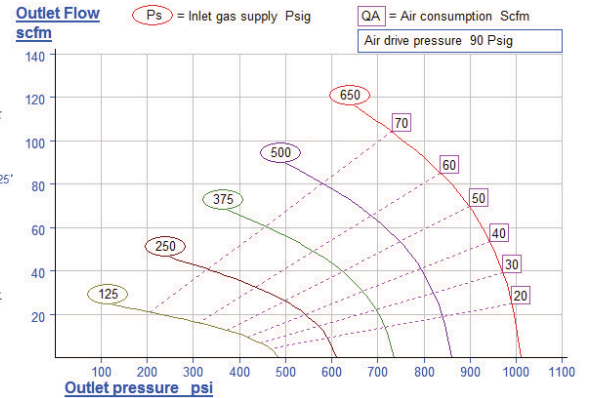
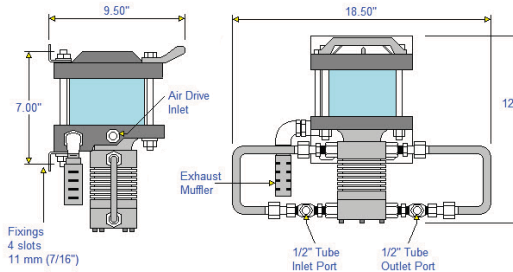

AAD-15

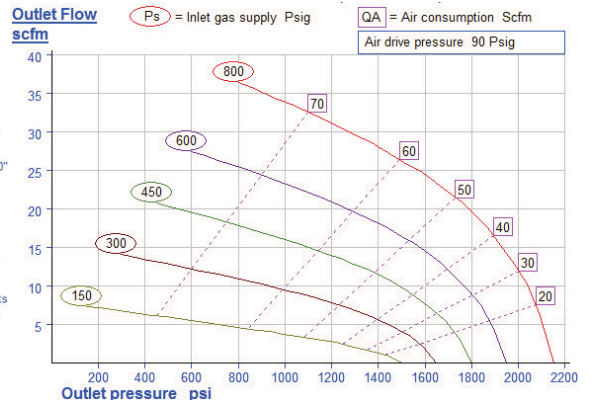
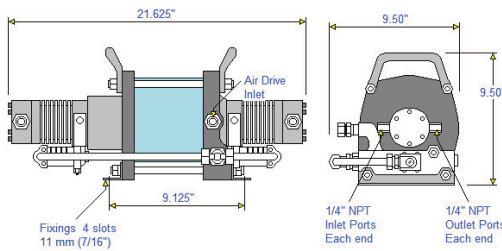

AAD-30

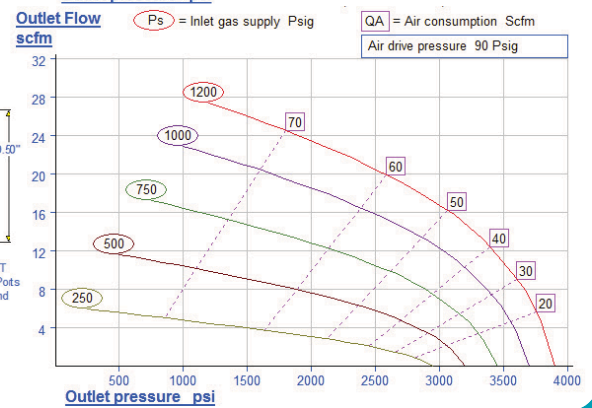
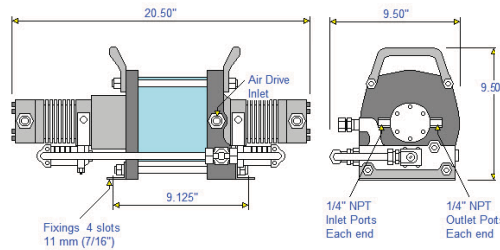

Optional Modifications

Number	Description	Number	Description	Number	Description
-C	Air Controls	29702	Single Stroke Modification	53375-1	200PSIG Downstream Regulator AAD-2
28881	External Pilot Modification	29960	Receiver and Controls AAD-2	53376	Regulator, Air Pilot Switch, & Relief Valve AAD-5
17860	Electrical Stroke Counter	51050	Extreme Service Cycling		
25721	Mechanical Stroke Counter	53375	125PSIG Downstream Regulator AAD-2		
29376	Three Way Cycling Spool				

AAT Series, Double Acting, Two Stage

AAT-7/30

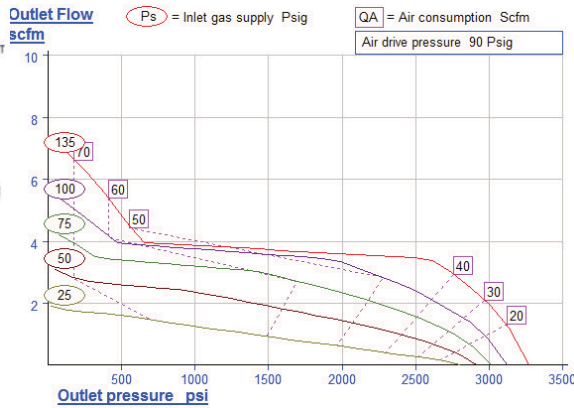
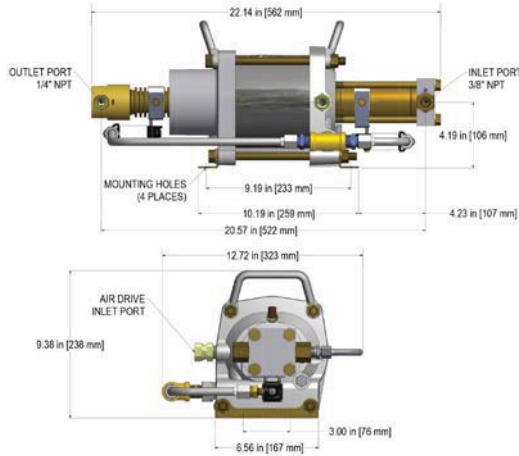

- Pressure output up to 5000 psi (345 bar)
- Requires less air drive since the inlet pressure itself provides a substantial portion of the driving force.
- AAT-7/30 Maximum Outlet Pressure 20 Pa + 4 Ps
- AAT-15/30 Maximum Outlet Pressure 30 Pa + 2 Ps
- AAT-30/50 Maximum Outlet Pressure 50 Pa + 1.6 Ps

AAT-15/30

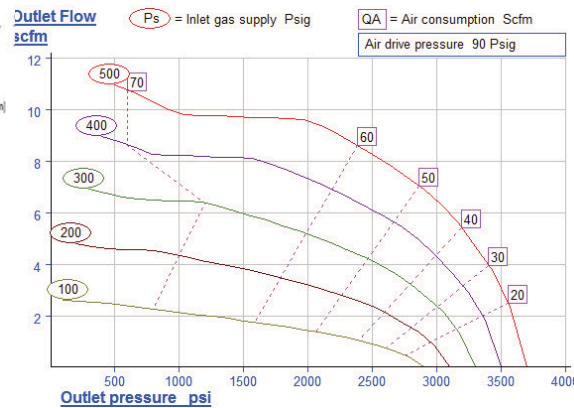
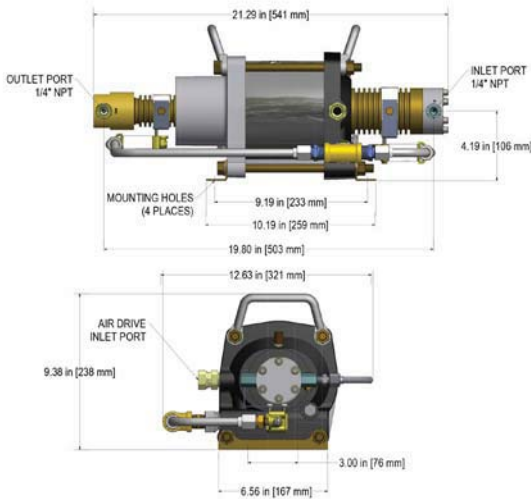

AAT-30/50

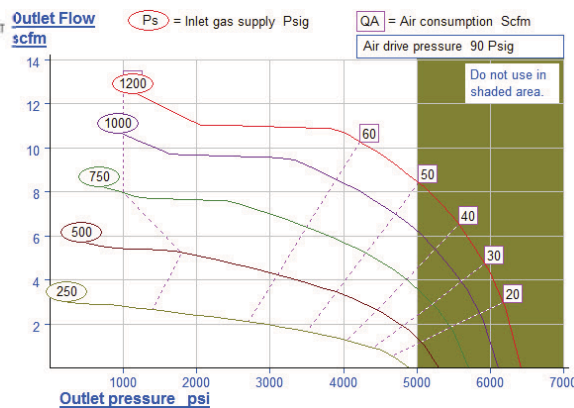
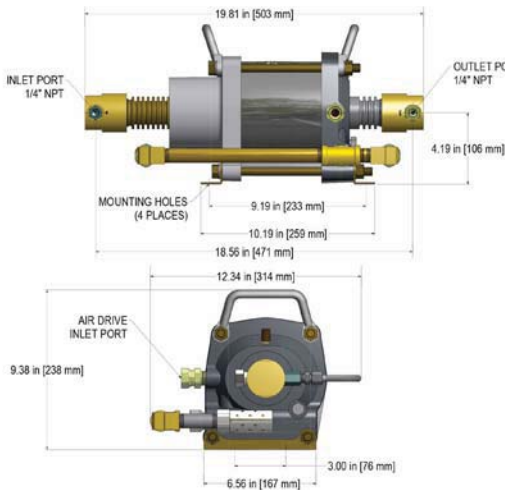

Optional Modifications

Number	Description
-C	Air Controls
28881	External Pilot Modification
17860	Electrical Stroke Counter
25721	Mechanical Stroke Counter
29376	Three Way Cycling Spool

Number	Description
29702	Single Stroke Modification
29960	Receiver and Controls AAD-2
51050	Extreme Service Cycling
53375	125PSIG Downstream Regulator AAD-2

Number	Description
53375-1	200PSIG Downstream Regulator AAD-2
53376	Regulator, Air Pilot Switch, & Relief Valve AAD-5

Standard Vertical Air Amplifier Systems

A complete pneumatic system designed to provide amplified pressure and momentary high flow. Vertical receiver reduces footprint, saving floor space. Utilizes available plant air (up to 95 psi) to both the supply and drive inlets which automatically stalls once the storage tank has been filled to about double the supply pressure. The amplifier will sense any use of air from the tank, and resume operation again to stall at about 5 times supply pressure. The regulator on the tank output is provided to control the output pressure and flow, up to about (momentarily) 150 scfm. Also included is an ASME coded safety relief valve on the tank set at 400 psig.



Model AAD-5-VT15-400 Shown

All models are available with optional factory installed controls. Control option details will vary depending on pressures, application requirements and which amplifier models are used. The schematics and charts below describe the most common options. Any model can be converted to cycle with external pilot air.

Standard Air Controls for all AA series models

Specify using -C after model number. Provide rough max. P_o control by regulating the P_a only if P_s is constant. Regulation of P_a will reduce peak performance.

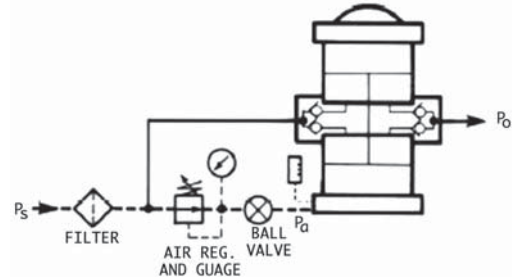

Normally Closed Air Pilot Switch for all AA series Models To Prevent No-Load Runaway

Specify MA-1 (after model number) and requested setting within 50-180 psi (increasing) range. e.g.: AAD-2-MA-1 set at 70 psi increasing

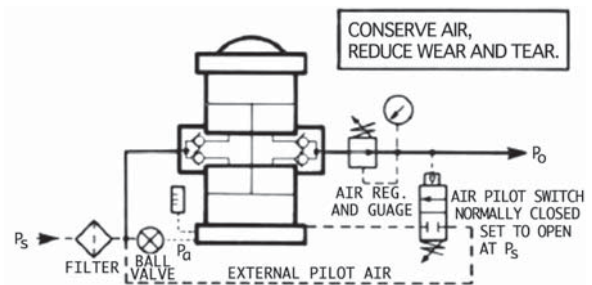

Semi-Standard Air Controls AAD-2 Model Only

Specify using -53375 before model number AAD-2-C. Provides good max P_o control with peak performance max. reg. P_o 124 psi, 200 psi spring optional. Optional 200 psi spring.

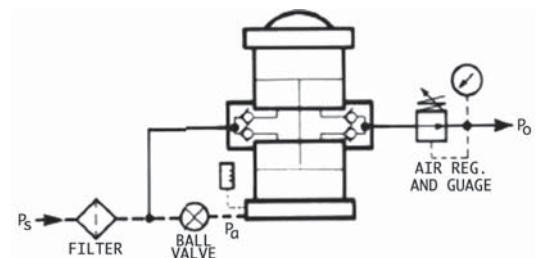

Normally Open Air Pilot Switch with Relief Valve & Air Controls - AAD-5

Specify using -53376 before model number AAD-5. Good max P_o control to 200 psi with port to add 1-1/2 or 5 gal. ASME receiver (290 psi)

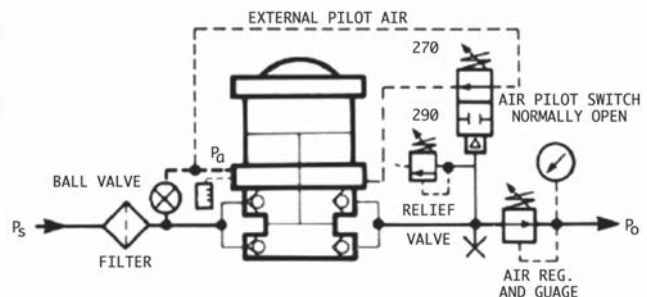

8AAD-2 Series, Double Acting, Single Stage

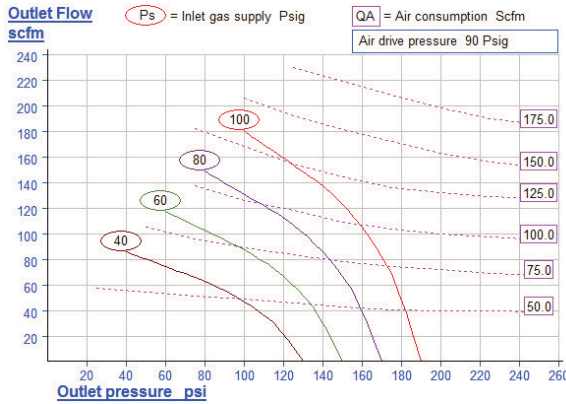

- 8" Drive (203mm)
- High output flow air pressure amplifier
- Pressure outputs up to 20bar (300 psi)
- Maximum outlet pressure is area ratio x drive pressure plus supply pressure
- Requires less air drive since the inlet air pressure itself provides a substantial portion of the driving force

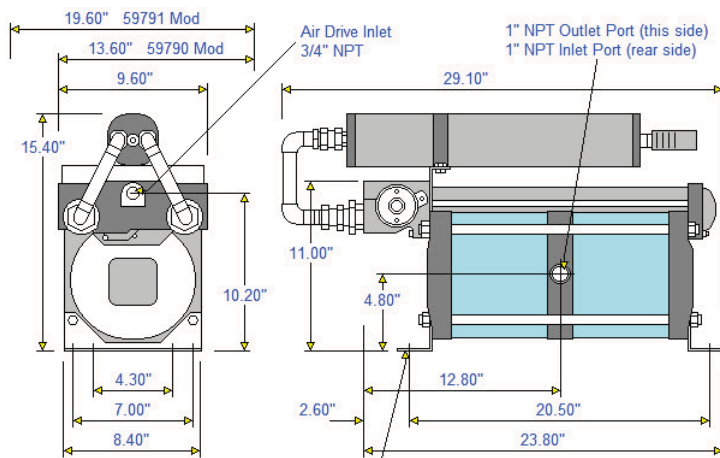

Optional Modifications

Standard Modification Schematics

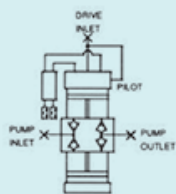

Basic 8AAD-2

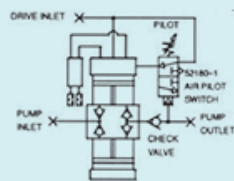

59790- 8AAD-2

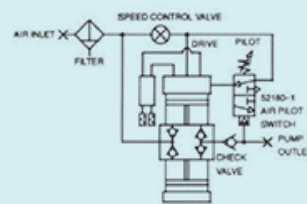

59791- 8AAD-2

Number	Description
-C	Air Controls
29125	External Pilot Modification
17860	Electrical Stroke Counter
25721	Mechanical Stroke Counter
29702	Single Stroke Modification
54312	Extreme Service Cycling Mod
59790	NO Load Run Away Mod
59791	59790 With Air Controls
59462	8AAD-2 With Receiver and Controls

59462-8AAD-2 System

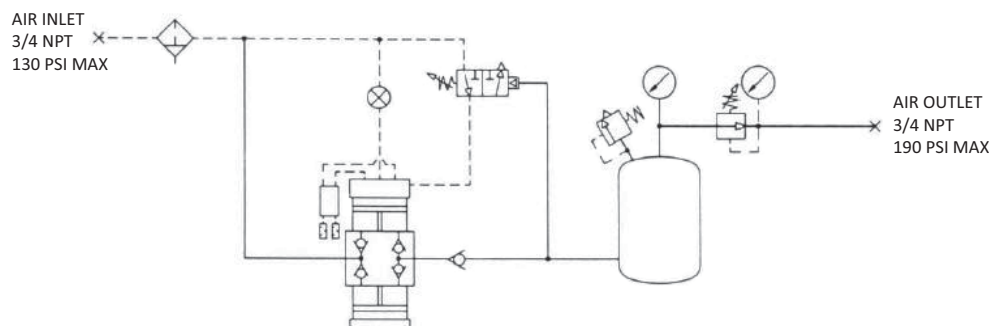

CELEBRATING OVER 65
YEARS OF HYDRAULIC AND
PNEUMATIC ENGINEERING
EXPERIENCE IN THE DESIGN
AND MANUFACTURING
OF HIGH PRESSURE
GENERATING EQUIPMENT
AND CONTROLS



Haskel International, LLC.

100 East Graham Place
Burbank, CA 91502 USA
Tel: 818-843-4000 / Fax: 818-556-2549 or 818-841-4291
Email: sales@haskel.com
www.haskel.com

Haskel Europe Ltd.

North Hylton Road
Sunderland SR5 3JD, England UK
Tel: 44-191-549-1212 / Fax: 44-191-549-0911
Email: sales@haskel-europe.com
www.haskel-europe.com

Haskel Middle East

P.O. Box 262384 Jebel Ali, Dubai, United Arab Emirates
Tel: +971 4 8875656 / Fax: +971 4 88 75647
Email: sales@haskel.ae

Haskel Asia

23 Tagore Lane #03-06
Tagore 23 Warehouse Complex, Singapore 787601
Tel: 65-6455-7559 / Fax: 65-6455-2841
Email: sales@haskel.com.sg
www.haskel.com.sg

**For further information on Haskel
products, please visit us online at
www.haskel.com**